

# User's Manual

## Digital PID Temperature Controller Process Controller

VER 1.3 2021-02

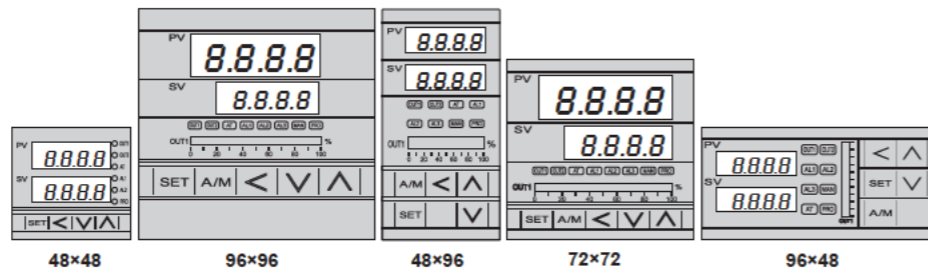

### 1 Notice

- Warning**
  - An external protection device must be installed if failure of this instrument could result in damage to the instrument, equipment or injury to personnel.
  - All wiring must be completed before power is turned on to prevent electric shock, fire or damage to instrument and equipment.
  - This instrument must be used in accordance with the specifications to prevent fire or damage to instrument and equipment.
  - This instrument is not intended for use in locations subject to flammable or explosive gases.
  - Do not touch high-voltage connections such as power supply terminals, etc. to avoid electric shock.
  - TAIWAN INSTRUMENT & CONTROL Co., Ltd. is not responsible if this instrument is repaired, modified or disassembled by other than factory-approved personnel. Malfunction can occur and warranty is void under these conditions.

### Caution

- This product is intended for use with industrial machines, test and measuring equipment. It is not designed for use with medical equipment and nuclear energy.
- This is a Class A instrument. In a domestic environment, this instrument may cause radio interference, in which case the user may be required to take additional measures.
- This instrument is protected from electric shock by reinforced insulation. Provide reinforced insulation between the wire for the input signal and the wires for instrument power supply, source of power and loads.
- This instrument is designed for installation in an enclosed instrumentation panel. All high-voltage connections such as power supply terminals must be enclosed in the instrumentation panel to avoid electric shock by operating personnel.
- All precautions described in this manual should be taken to avoid damage to the instrument or equipment.
- All wiring must be completed before power is turned on to prevent electric shock, instrument failure, or incorrect action.
- The power must be turned off before repairing work for input break and output failure including replacement of sensor, contactor or SSR, and all wiring must be completed before power is turned on again.
- Prevent metal fragments or lead wire scraps from falling inside instrument case to avoid electric shock, fire or malfunction.
- Please use crimp terminals suitable for M3 screws, as shown below.

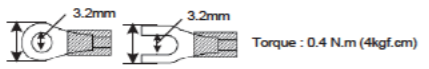

- Tighten each terminal screw to the specified torque found in the manual to avoid electric shock, fire or malfunction.
- When the thermocouple wiring is extended, please use the compensation lead of the corresponding type to this thermocouple.

### 2 Basic Function Setting

#### 2.1 Change Input Type

1. PV 88.25 SV 888.0	Display after power-on.	2. PV 88.25 SV 888.2	Hold <b>SET</b> key + <b>&lt;</b> key 3 seconds, to enter LEVEL_3 upper display showing "INPT" with lower display showing current input type.
3. PV 88.25 SV 888.2	Press <b>&lt;</b> key the lower display flashes.	4. PV 88.25 SV 888.2	Press <b>&gt;</b> key and <b>&lt;</b> key to enter the intended input type.
5. PV 88.25 SV 888.2	Press <b>SET</b> key to store new value of INPT.	Modify input type needs to interchange of jumper location, and it needs to recalibration for linear input type change.	

#### 2.2 SV Setting

1. PV 88.25 SV 888.0	Display after power-on.	2. PV 88.25 SV 000.0	When <b>&lt;</b> key is pressed, the lower display flashes.
3. PV 88.25 SV 0.150	Press <b>&gt;</b> key and <b>&lt;</b> key to adjust set value.	4. PV 88.25 SV 81.50	Press <b>SET</b> key to store new value of SV.

#### 2.3 RUN/STOP Mode Selection

1. PV 88.25 SV 81.50	Display after power-on.	2. PV 88.25 SV 560P	Press <b>SET</b> key to enter parameter setup display, with "R_S" shown on the upper display.
3. PV 88.25 SV 560P	When <b>&lt;</b> key is pressed, the lower display flashes.	4. PV 88.25 SV 8F0P	Press <b>&gt;</b> key or <b>&lt;</b> key to select RUN/STOP mode.
5. PV 88.25 SV 8F0P	Press <b>SET</b> key to store new value of R_S.	When controller is in STOP mode, it disable OUTPUT and ALARM functions.	

#### 2.4 Setting PID Value Automatically(Auto-tuning)

1. PV 88.25 SV 81.50	Display after power-on.	2. PV 88.25 SV 88.88	Press <b>SET</b> key to get parameter setup display, as "OFF" will be shown on the upper display.
3. PV 88.25 SV 88.88	When <b>&lt;</b> key is pressed, the lower display flashes.	4. PV 88.25 SV 88.88	Press <b>&gt;</b> key or <b>&lt;</b> key to select auto tuning execution or not.
5. PV 88.25 SV 88.88	Press <b>SET</b> key to store new value of AT.	When auto-tuning AT LED lamp lit and start to output, through a few circles to get new PID value with the precise control, if finished the AT LED will be lamp off.	

#### 2.5 Setting PID Value Manually

1. PV 88.25 SV 888.0	Display after power-on.	2. PV 88.25 SV 88.30	Hold <b>SET</b> key 3 seconds, then entering into LEVEL_2 upper display showing "P1", with lower display show current P1 value.
3. PV 88.25 SV 00.30	When <b>&lt;</b> key is pressed, the lower display flashes.	4. PV 88.25 SV 05.00	Press <b>&gt;</b> key and <b>&lt;</b> key to set the intended P1 value.
5. PV 88.25 SV 85.00	Press <b>SET</b> key to store new value of P1.	By the same procedure, use the same ways to set integral time(I1) and derivative time(D1).	

#### 2.6 Controlling With ON/OFF Action

1. PV 88.25 SV 88.50	Display after power-on.	2. PV 88.25 SV 88.30	Hold <b>SET</b> key 3 seconds, then entering into LEVEL_2, as upper display shows "P1", with lower display showing current P1 value.
3. PV 88.25 SV 00.30	When <b>&lt;</b> key is pressed, the lower display flashes, upper display.	4. PV 88.25 SV 00.00	Press <b>&gt;</b> key until P1 = 0.0
5. PV 88.25 SV 88.00	Press <b>SET</b> key to store new value.	6. PV 88.25 SV 88.88	Press <b>SET</b> key to get parameter setup display, "HYS1" shown on the upper display.
7. PV 88.25 SV 88.25	When <b>&lt;</b> key is pressed, the lower display flashes.	8. PV 88.25 SV 88.40	Press <b>&gt;</b> key and <b>&lt;</b> key to set the intended HYS1 value.
9. PV 88.25 SV 88.40	Press <b>SET</b> key to store new value.	Heat mode formula: PV ≥ (SV + HYS1) → OUT1 OFF PV ≤ (SV - HYS1) → OUT1 ON Cool mode formula: PV ≥ (SV + HYS1) → OUT1 ON PV ≤ (SV - HYS1) → OUT1 OFF	

#### 2.7 Alarm Mode Setting

1. PV 88.25 SV 888.0	Display after power-on.	2. PV 88.25 SV 88.22	Hold <b>SET</b> key + <b>&lt;</b> key 3 seconds, then entering into LEVEL_3 upper display showing "INPT" with lower display showing current input type.
3. PV 88.25 SV 88.22	Press <b>SET</b> key to get parameter setup display, with "ALD1" shown on the upper display.	4. PV 88.25 SV 88.22	When <b>&lt;</b> SHIFT key is pressed, the lower display flashes.
5. PV 88.25 SV 88.22	Press <b>&gt;</b> key and <b>&lt;</b> key to set the intended ALD1 value.	6. PV 88.25 SV 88.22	Press <b>SET</b> key to store new value of ALD1.

#### 2.8 Alarm Value Setting

1. PV 88.25 SV 888.0	Display after power-on.	2. PV 88.25 SV 88.14	Press <b>SET</b> key to get parameter setup display, with "AL1H" shown on the upper display.
3. PV 88.25 SV 00.00	When <b>&lt;</b> key is pressed, the lower display flashes.	4. PV 88.25 SV 00.20	Press <b>&gt;</b> key and <b>&lt;</b> key to set the intended AL1H value.
5. PV 88.25 SV 88.20	Press <b>SET</b> key to store new value of AL1H.		

#### 2.9 Controlling With Manual Control

1. PV 88.25 SV 81.50	Display after power-on.	2. PV 88.25 SV 88.20	Press <b>SET</b> key to get parameter setup display, with "A_M" shown on the upper display.
3. PV 88.25 SV 88.20	When <b>&lt;</b> key is pressed, the lower display flashes.	4. PV 88.25 SV 00.00	Press <b>&gt;</b> key or <b>&lt;</b> key to select AUTO/MAN mode.
5. PV 88.25 SV 00.00	Press <b>SET</b> key to store new value of A_M.	6. PV 88.25 SV 84.50	Press <b>SET</b> key to get parameter setup display, with "MOUT" shown on the upper display.
7. PV 88.25 SV 04.50	When <b>&lt;</b> key is pressed, the lower display flashes.	8. PV 88.25 SV 10.00	Press <b>&gt;</b> key and <b>&lt;</b> key to set the intended MOUT value.
9. PV 88.25 SV 10.00	Press <b>SET</b> key to store new value of MOUT.	In manual mode and MOUT=100.0, output=100.0% continuously. In manual mode and MOUT=20.0, output=20.0% continuously.	

### 3 Flow Chart Of Parameter Setting

#### 3.1 Parameter Structure

The NFY controller is an original dual-loop controller. The parameter group of Level 1~Level 4 is of LOOP type. There are two copies kept in LOOP1 and LOOP2. Level 5 parameter group non-LOOP type is of an independent, linked with Level 4 of LOOP1 or LOOP2, as the parameter structure is shown in the diagram below.

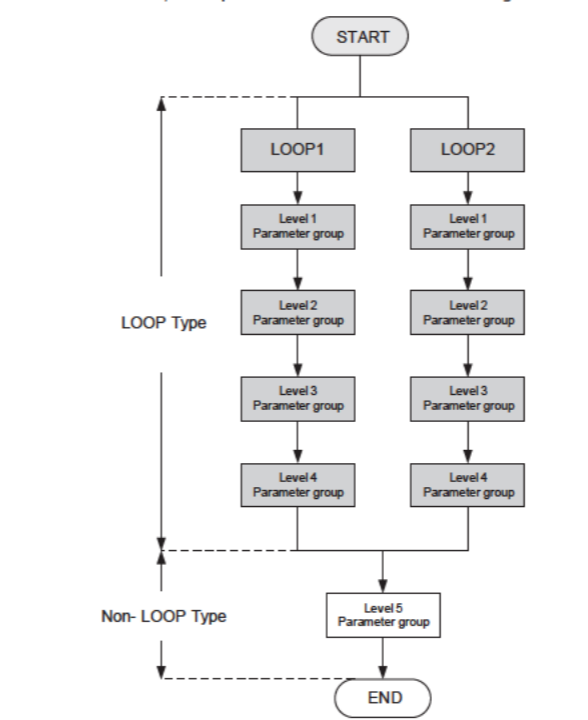

#### 3.2 Level Operation Mode

- LEVEL 1 enter to the LEVEL 2**  
Hold SET key for 3 seconds then entering into LEVEL 2
- LEVEL 1 enter to the LEVEL 3**  
Hold SET key + SHIFT key for 3 seconds then entering into LEVEL 3
- LEVEL 2 return to the LEVEL 1**  
Hold SET key for 3 seconds then return to LEVEL 1
- LEVEL 2 enter to the LEVEL 3**  
Hold SET key for 3 seconds then return to LEVEL 3
- LEVEL 1 enter to the LEVEL 4**  
Hold SET key for 3 seconds then entering into LEVEL 2, in LEVEL 2 press SET key to find parameter "LOCK", modify LOCK value from current value to 1111 then hold SET key + SHIFT key for 3 seconds then entering into LEVEL 4
- LEVEL 2 enter to the LEVEL 5**  
Hold SET key for 3 seconds then entering into LEVEL 2, in LEVEL 2 press SET key to find parameter "LOCK", modify LOCK value from current value to 1000 then hold SET key + SHIFT key for 3 seconds then entering into LEVEL 5
- LEVEL 3 return to the LEVEL 1**  
hold SET key + SHIFT key for 3 seconds then return to LEVEL 1
- LEVEL 3 return to the LEVEL 2**  
Hold SET key for 3 seconds then return to LEVEL 2
- LEVEL 4 return to the LEVEL 1**  
Hold SET key + SHIFT key for 3 seconds then return to LEVEL 1
- LEVEL 4 return to the LEVEL 2**  
Hold SET key for 3 seconds then return to LEVEL 2
- LEVEL 5 return to the LEVEL 1**  
Hold SET key + SHIFT key for 3 seconds then entering into LEVEL 1
- LEVEL 5 return to the LEVEL 2**  
Hold SET key for 3 seconds then return to LEVEL 2

#### 3.3 Level Operation Diagram

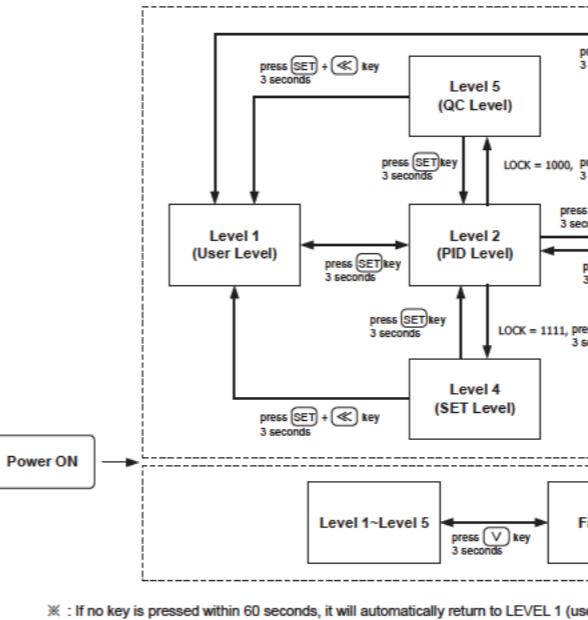

#### 3.4 Data Lock Function

LOCK provides a parameter protection function to prevent the operator from touching or modifying important parameters. Conversely, when the parameter cannot be modified, please check that the set value of LCK.

LOCK	LEVEL					Descriptions
	Level_1 USER Level	Level_2 PID Level	Level_3 INPUT Level	Level_4 SET Level	Level_5 QC Level	
0000	⊙	⊙	⊙	X	X	All parameters of Level 1, 2 & 3 are able to be modified (Factory default setting)
1111	⊙	⊙	X	⊙	X	All parameters of Level 1, 2 & 4 are able to be modified
1000	⊙	⊙	X	X	⊙	All parameters of Level 1, 2 & 5 are able to be modified
0001	⊙	⊙	X	X	X	Only SV, LOOP, R_S, A_M, LOCK can be modified
0101	⊙	⊙	X	X	X	Only LOCK can be modified
0110	⊙	⊙	X	X	X	Only parameters of Level 1 and LOCK can be modified
Other	⊙	⊙	⊙	X	X	Once jumping to other levels, LOCK will be automatically restored to 0000

#### 3.5 Level 1 (User Level) All Parameters Display

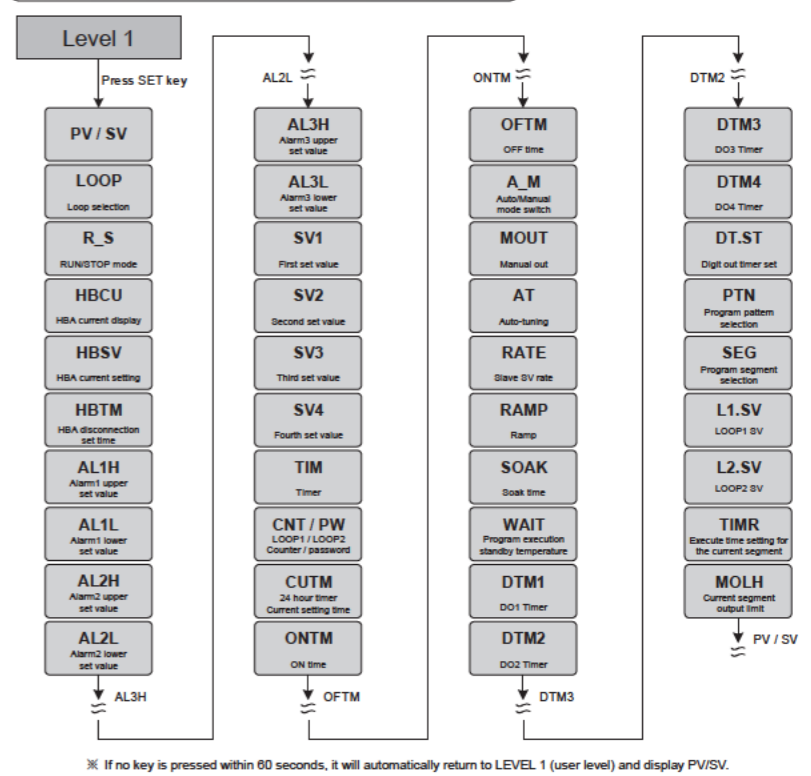

#### 3.6 Level 2 (PID Level) All Parameters Display

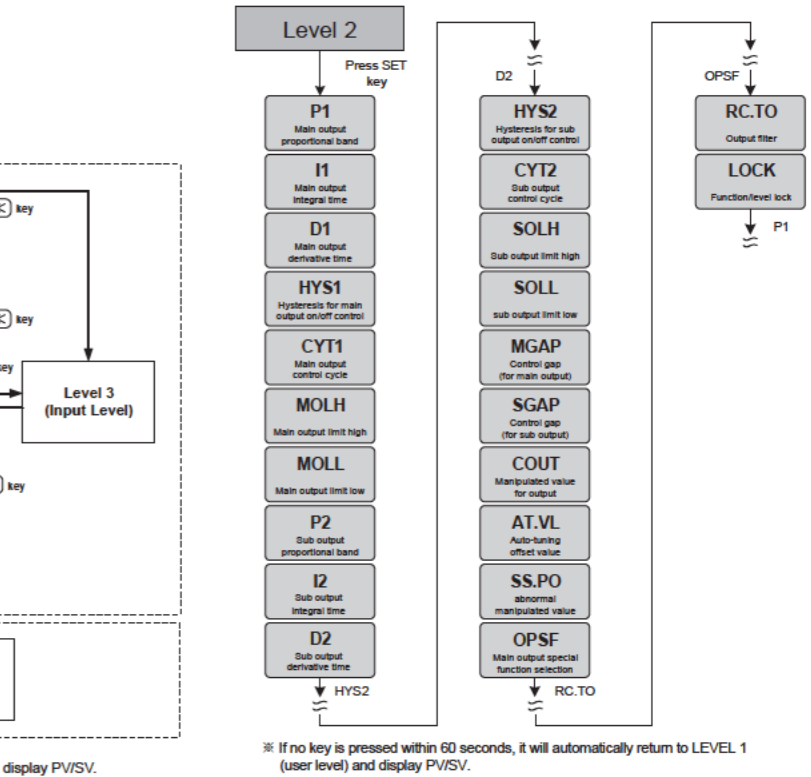

※ : If no key is pressed within 60 seconds, it will automatically return to LEVEL 1 (user level) and display PV/SV.

※ : If no key is pressed within 60 seconds, it will automatically return to LEVEL 1 (user level) and display PV/SV.

### 3.7 Level 3 (Input Level) All Parameters Display

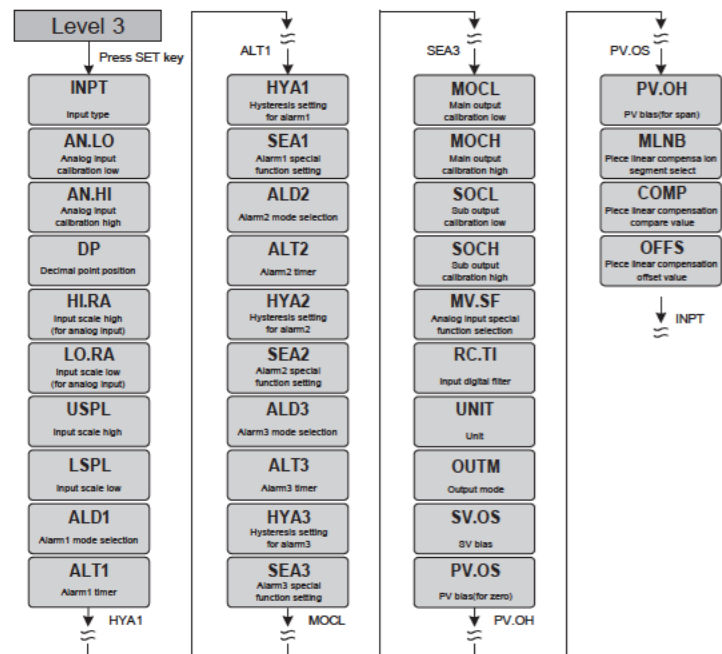

※ If no key is pressed within 60 seconds, it will automatically return to LEVEL 1 (user level) and display PV/SV.

### 3.8 Level 4 (Setting Level) All Parameters Display

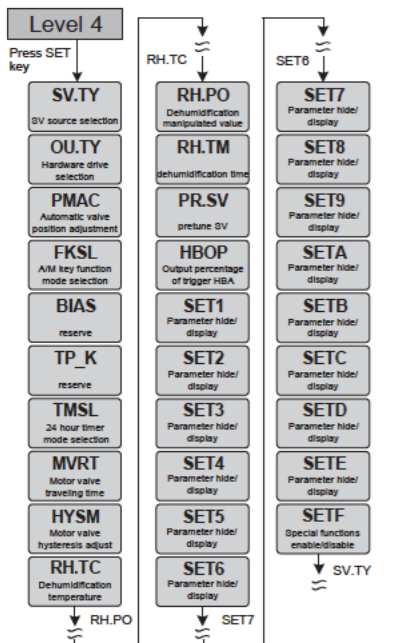

※ If no key is pressed within 60 seconds, it will automatically return to LEVEL 1 (user level) and display PV/SV.

### 4.0 Fast Parameter Access

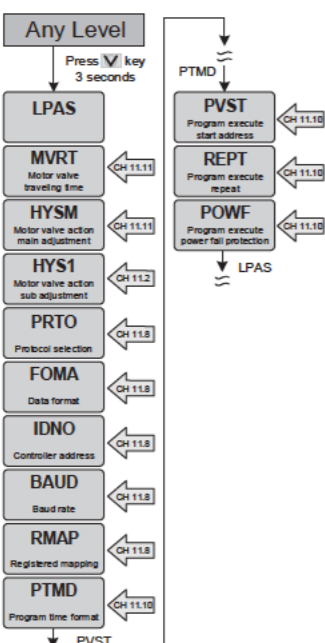

### 3.9 Level 5 (Quality Control) All Parameters Display

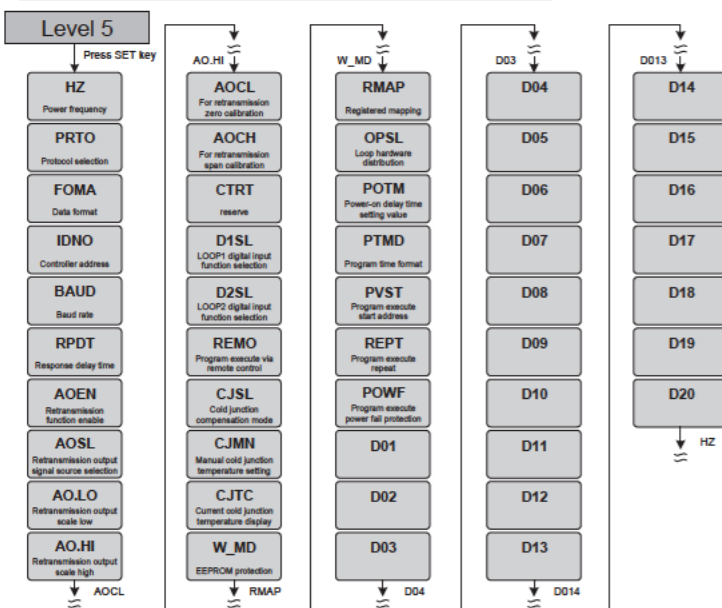

※ If no key is pressed within 60 seconds, it will automatically return to LEVEL 1 (user level) and display PV/SV.

### 4 Parameters Hide/Display Table On Level 4

Parameter	0	1	Function
SET1_1	0	hide	HBCU HBSV HBTM HBOP
SET1_2	0	hide	AL1H AL1L
SET1_3	0	hide	AL2H AL2L
SET1_4	0	hide	AL3H AL3L
SET2_1	0	hide	SV1 SV2
SET2_2	0	hide	SV3 SV4
SET2_3	0	hide	TIM
SET2_4	0	hide	TIM
SET3_1	0	hide	CUTM ONTM OFTM
SET3_2	0	hide	A_M
SET3_3	0	hide	AT
SET3_4	0	hide	R_S
SET4_1	0	hide	WAIT
SET4_2	0	hide	DTM1 DTM2 DTM3 DTM4
SET4_3	0	hide	DT.ST
SET4_4	0	hide	PV1 PV2
SET5_1	0	hide	reserve
SET5_2	0	hide	MOLH MOLL
SET5_3	0	hide	reserve
SET5_4	0	hide	SOLH SOLL
SET6_1	0	hide	COUT
SET6_2	0	hide	AT.VL SS.PO
SET6_3	0	hide	QPSF RC.TO
SET6_4	0	hide	LOOP L2.SV MOLH
SET7_1	0	hide	AN.LO AN.HI DP
SET7_2	0	hide	HI.RA LO.RA
SET7_3	0	hide	LSPL USPL
SET7_4	0	hide	ALD1 ALT1 HYA1 SEA1
SET8_1	0	hide	ALD2 ALT2 HYA2 SEA2
SET8_2	0	hide	ALD3 ALT3 HYA3 SEA3
SET8_3	0	hide	MOCL MOCH
SET8_4	0	hide	SOCL SOCH
SET9_1	0	hide	MV.SF
SET9_2	0	hide	RC.TI
SET9_3	0	hide	UNIT
SET9_4	0	hide	OUTM
SETA_1	0	hide	SVOS
SETA_2	0	hide	PV.OS PV.OH
SETA_3	0	hide	MLNB COMP OFFS
SETA_4	0	hide	Super SV function disable
SETB_1	0	hide	OU.TY
SETB_2	0	hide	reserve
SETB_3	0	hide	FKSL
SETB_4	0	hide	BASE TP.K
SETC_1	0	hide	TMSL
SETC_2	0	hide	MVRT HYSM
SETC_3	0	hide	RH.TC RH.PO RH.TM
SETC_4	0	hide	PR.SV PR.SV
SETD_1	0	hide	PRTO FOMA IDNO BAUD RPDT
SETD_2	0	hide	AOEN ACSL AO.LO AO.HI AOCL AOCH
SETD_3	0	hide	CTRT D1SL D2SL
SETD_4	0	hide	REMO

Parameter	0	1	Function
SETE_1	0	hide	C.JSL C.JMN C.JTC W_MD RMAP OP.SL POTM
SETE_2	0	hide	D01 D02 D03 D04 D05 D06 D07
SETE_3	0	hide	reserve
SETE_4	0	hide	RAMP

Parameter	0	1	Function
SETF_1	0	hide	valve control close Relay b contact out
SETF_2	0	hide	in abnormal condition MOUT = SS.PO
SETF_3	0	hide	PV Hysteresis mode enable
SETF_4	0	hide	enable piece linear compensation function

### 5 Alarm Mode

There is a dot on the led display for alarm hold action, such as →  $\overline{BEHO}$  (Deviation high with hold action)  
When the controller boot completed, the PV is within the alarm range, and no alarm action will be generated at this time, until the PV exceed alarm range then enter the alarm range again the alarm will be activated.

▲ : SV ▲ : Alarm set value X : 1/2/3 (There are up to 3 sets of alarms)

ALDX	Index value	Alarm mode	Description
NONE	0	No alarm function	Not drive any alarm relays and the corresponding LED lamp.
DEHI	1	Deviation high (With hold action)	Formula: $PV \geq (SV + ALXH) \rightarrow$ Alarm ON $PV \leq (SV + ALXH - HYAX) \rightarrow$ Alarm OFF
DELO	2	Deviation low (With hold action)	Formula: $PV \leq (SV + ALXL) \rightarrow$ Alarm ON $PV \geq (SV + ALXL + HYAX) \rightarrow$ Alarm OFF
DEHL	3	Deviation highlow (With hold action)	Formula: $PV \leq (SV + ALXL) \rightarrow$ Alarm ON $PV \geq (SV + ALXL + HYAX) \rightarrow$ Alarm OFF $PV < (SV + ALXH - HYAX) \rightarrow$ Alarm OFF
BAND	4	Band (With hold action)	Formula: $PV \geq (SV + ALXH) \rightarrow$ Alarm ON $PV < (SV + ALXH) \rightarrow$ Alarm OFF $PV \geq (SV + ALXL) \rightarrow$ Alarm ON $PV < (SV + ALXL) \rightarrow$ Alarm OFF
PRHI	5	Process high (With hold action)	Formula: $PV \geq ALXH \rightarrow$ Alarm ON $PV \leq (ALXH - HYAX) \rightarrow$ Alarm OFF
PRLO	6	Process low (With hold action)	Formula: $PV \leq ALXL \rightarrow$ Alarm ON $PV \geq (ALXL + HYAX) \rightarrow$ Alarm OFF
PEND	7	Program end	When the program is end, the alarm action *This mode only available in program type controller
SYAB	8	System error	The alert action, when PV displays error message
HBA	9	HBA (Heater Break Alarm)	Activated conditions : 1. Heater current(HBCU) is less the HBSV set value 2. OUT1 manipulated value exceed HBOP set value 3. Fit with Condition 1 and 2 and exceed set the seconds of HBTM
MSOK	10	soak timer	Boot completed, the alarm is ON. When PV $\geq$ target SV start the soak timer, alarm and control function are turned OFF in soak time finish please refer to chapter 11.11 RAMP + SOAK
DEHI	11	Deviation high	Formula: $PV \geq (SV + ALXH) \rightarrow$ Alarm ON $PV \leq (SV + ALXH - HYAX) \rightarrow$ Alarm OFF
DELO	12	Deviation low	Formula: $PV \leq (SV + ALXL) \rightarrow$ Alarm ON $PV \geq (SV + ALXL + HYAX) \rightarrow$ Alarm OFF
DEHL	13	Deviation highlow	Formula: $PV \leq (SV + ALXL) \rightarrow$ Alarm ON $PV \geq (SV + ALXL + HYAX) \rightarrow$ Alarm OFF $PV < (SV + ALXH - HYAX) \rightarrow$ Alarm OFF
BAND	14	Band	Formula: $PV \geq (SV + ALXH) \rightarrow$ Alarm ON $PV < (SV + ALXH) \rightarrow$ Alarm OFF $PV \geq (SV + ALXL) \rightarrow$ Alarm ON $PV < (SV + ALXL) \rightarrow$ Alarm OFF

ALDX	Index value	Alarm mode	Description
PRHI	15	Process high	Formula: $PV \geq ALXH \rightarrow$ Alarm ON $PV \leq (ALXH - HYAX) \rightarrow$ Alarm OFF
PRLO	16	Process low	Formula: $PV \leq ALXL \rightarrow$ Alarm ON $PV \geq (ALXL + HYAX) \rightarrow$ Alarm OFF
PRUN	17	Program run	When the program is being executed, the alarm action *This mode only available in program type controller
SYNO	18	System normal	The Alert action, when PV normal displays( no error message)
SOAK	19	Ramp Soak Timer	Boot completed, the alarm is ON 1. RAMP SV reach target SV 2. PV $\geq$ target SV When both of the above conditions are true start the soak timer, alarm and control function are turned OFF in soak time finish (in this function ramp function is necessary)
TIM	20	Timer	Alarm action in time up *This mode only available in Digital Input function
CNT	21	Counter	Alarm action after counter value is reached *This mode only available in Digital Input function
CUTM	22	24H Timer	When CUTM = ONTM, alarm activates When CUTM = OFTM, alarm stops
FSOK	23	soak timer	Boot completed, the alarm is OFF. when PV $\geq$ target SV start the soak timer, alarm is turned ON and the control function keep ON in soak time finish

### Alarm Example

Example 1 : Deviation low, the difference between alarm hold action and without alarm hold action, shown in the diagram below

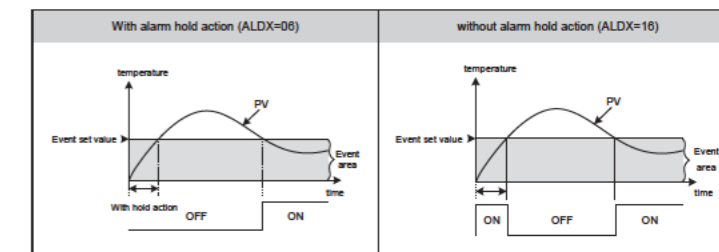

### 6 Modification Of Input Signal

#### 6.1 Input Modify To Thermocouple

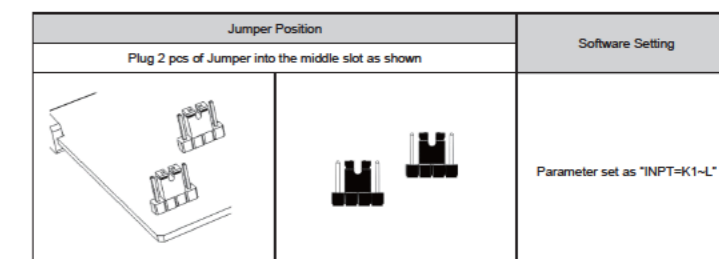

#### 6.2 Input Modify To RTD

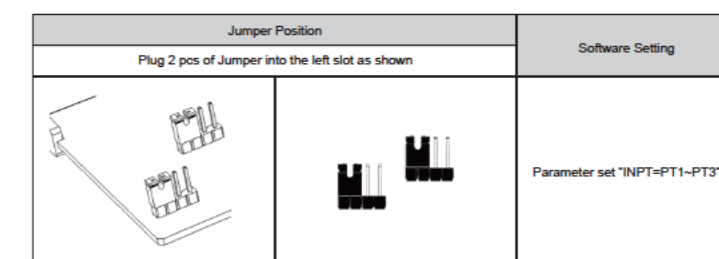

### 7 Error Message

If controller exhibits any of the following issues, please proceed with the following procedures

Symbol	Error	Solution
$\overline{INER}$	INIE: Input1 Error	Check whether input loop is opened or wiring is incorrect.
$\overline{UUUU}$	UUUU: PV is above USPL	Check whether the input value is correct or not.
$\overline{NNNN}$	NNNN: PV is below LSPL	Check whether the input value is correct or not.

If any of the indication in the table below appear, the controller need to be repaired do not try to repair the controller by yourself, order a new one or contact us to repair.

Symbol	Error	Solution
$\overline{ADCF}$	ADCF: A/D convert failed	Please send for repair.
$\overline{CJER}$	CJER: Cold junction compensation failed	Please send for repair.
$\overline{RAMF}$	RAMF: EEPROM failed	Please send for repair.