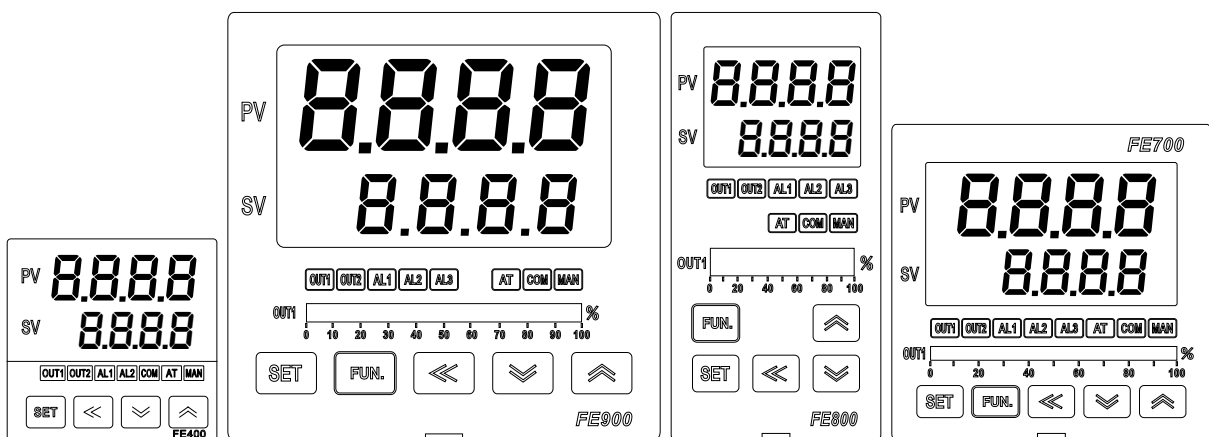

Digital Temperature Controller

FE400/700/800/900

FE250/251/300

Ver 1.6

Operation Manual



Preface

Thank you for purchasing the FE series digital temperature controllers.

This User's Manual contains instructions for mounting, functions, operations and notes when operating the FE series digital temperature controllers.

To prevent accidents arising from the misuse of this controller, please ensure the operator receives this manual.

Notes

- This instrument should be used in accordance with the specifications described in the manual. If it is not used according to the specifications, it may malfunction or cause a fire.
- Be sure to follow the warnings, cautions and notices. If they are not observed, serious injury or malfunction may occur.
- The contents of this instruction manual are subject to change without notice.
- Care has been taken to ensure that the contents of this instruction manual are correct, but if there are any doubts, mistakes or questions, please inform our company.
- Measures must be taken to ensure that the operator cannot touch power terminals or other high voltage sections.
- Any unauthorized transfer or copying of this document, in part or in whole, is prohibited.
- Producer is not liable for any damage or secondary damage(s) incurred as a result of using this product, including any indirect damage.



WARNING : This mark indicates precautions that must be taken if there is danger of electric shock, fire, etc., which could result in loss of life or injury.



CAUTION : This mark indicates that if these precautions and operating procedures are not taken, damage to the instrument may result.



WARNING

- An external protection device must be installed if failure of this instrument could result in damage to the instrument, equipment or injury to personnel.
- All wiring must be completed before power is turned on to prevent electric shock, fire or damage to instrument and equipment.
- This instrument must be used in accordance with the specifications to prevent fire or damage to instrument and equipment.
- This instrument is not intended for use in locations subject to flammable or explosive gases.
- Do not touch high-voltage connections such as power supply terminals, etc. to avoid electric shock.
- Producer is not responsible if this instrument is repaired, modified or disassembled by other than factory-approved personnel. Malfunction can occur and warranty is void under these conditions.

CAUTION

- This product is intended for use with industrial machines, test and measuring equipment. It is not designed for use with medical equipment and nuclear energy.
- This is a Class A instrument. In a domestic environment, this instrument may cause radio interference, in which case the user may be required to take additional measures.
- This instrument is protected from electric shock by reinforced insulation.
Provide reinforced insulation between the wire for the input signal and the wires for instrument power supply, source of power and loads.
- This instrument is designed for installation in an enclosed instrumentation panel. All high-voltage connections such as power supply terminals must be enclosed in the instrumentation panel to avoid electric shock by operating personnel.
- All precautions described in this manual should be taken to avoid damage to the instrument or equipment.
- All wiring must be completed before power is turned on to prevent electric shock, instrument failure, or incorrect action.
- The power must be turned off before repairing work for input break and output failure including replacement of sensor, contactor or SSR, and all wiring must be completed before power is turned on again.
- Prevent metal fragments or lead wire scraps from falling inside instrument case to avoid electric shock, fire or malfunction.

- Please use crimp terminals suitable for M3 screws, as shown below:

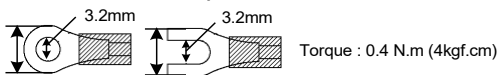

- Tighten each terminal screw to the specified torque found in the manual to avoid electric shock, fire or malfunction.
- When the thermocouple wiring is extended, please use the compensation lead of the corresponding type to this thermocouple.

Content

1.	Order Information	7
1.1	Versatile Controller	7
1.2	DIN Rail Controller	7
2.	Specifications	8
2.1	Versatile Specification	8
2.1	DIN Rail Specification	9
3.	Input Range Table	10
4.	Packing List & Label Information	10
4.1	Packing List Guide	10
4.2	Label Guide	11
4.2.1	FE400 label	11
4.2.2	FE700 label	11
4.2.3	FE800/900 label	11
4.2.4	FE250 label	12
4.2.5	FE251 label	12
4.2.6	FE300 label	12
5.	Parts Description	13
5.1	FE Versatile	13
5.2	FE250/251	14
5.3	FE300	14
6.	Installation	15
6.1	FE400 Dimensions	15
6.2	FE700 Dimensions	15
6.3	FE800 Dimensions	16
6.4	FE900 Dimensions	16
6.5	FE250/251 Dimensions	17
6.6	FE300 Dimensions	17
7.	Terminal Arrangement	18
7.1	FE400 Terminal Arrangement	18
7.2	FE700 Terminal Arrangement	19
7.3	FE800 Terminal Arrangement	20
7.4	FE900 Terminal Arrangement	21
7.5	FE250 Terminal Arrangement	22
7.6	FE251 Terminal Arrangement	23
7.7	FE300 Terminal Arrangement	24
8.	Basic Function Setting	25
8.1	Change Input Type	25
8.2	SV Setting	25
8.3	RUN/STOP Mode Selection	25
8.4	Setting PID Value Automatically(Auto-tuning)	25
8.5	Setting PID Value Manually	26
8.6	Controlling With ON/OFF Action	26

8.7	Alarm Mode Setting	26
8.8	Alarm Value Setting	27
8.9	Controlling With Manual Control.....	27
9.	Flow Chart Of Parameter Setting	28
9.1	Parameter Structure	28
9.2	Level Operation Mode	29
9.3	Level Operation Diagram	29
9.4	Data Lock Function	30
9.5	Level 1 (User Level) All Parameters Display	30
9.6	LEVEL_1 Parameter	31
9.7	Level 2 (PID Level) All Parameters Display	33
9.8	LEVEL_2 Parameter	34
9.9	Level 3 (Input Level) All Parameters Display	36
9.10	LEVEL_3 Parameter	37
9.11	Level 4 (Setting Level) All Parameters Display	39
9.12	LEVEL_4 Parameter	40
9.13	Level 5 (Quality Control) All Parameters Display	42
9.14	LEVEL_5 Parameter	43
9.15	Fast Parameter Access	46
9.16	Fast Level Parameter	47
10.	Parameters Hide/Display Table On Level 4	49
11.	Functional Descriptions	51
11.1	Input Calibration.....	51
11.2	Retransmission	52
11.3	Remote SV	54
11.4	Heater Break Alarm	56
11.5	FUN Key	58
11.6	Digital Input.....	60
11.7	Dehumidification Function	64
11.8	24-Hour Timer	65
11.9	Piece Linear Compensation	67
11.10	RAMP & SOAK.....	70
11.11	Password	73
11.12	Proportional Control.....	74
11.13	Master-Slave Communication	75
11.14	Auto-tuning	76
11.15	ON / OFF Control.....	78
11.16	Super SV	80
11.17	Input Math Function	81
12.	Alarm Action	84
12.1	Alarm Mode	86
12.2	Alarm Special Setting	89
12.3	Alarm Example	90

13.	Modification Of Output Module	91
13.1	Relay Control (1a)	91
13.2	Relay Control (1c)	91
13.3	SSR Control.....	91
13.4	Linear Control.....	91
13.5	Output Calibration Procedure Diagram	92
13.6	Output Calibration Steps	93
14.	Modification Of Input Signal	94
14.1	Input Modify To Thermocouple	94
14.2	Input Modify To RTD.....	94
14.3	Input Modify To Linear (4~20mA)	95
14.4	Steps For Input Calibration.....	96
15.	Error Message.....	97
16.	FE Communication Register Address Table	98
17.	FY Communication Register Address Table	100
18.	FE(Old) Communication Register Address Table	101
19.	Glossary Of Characters Used In This Manual	102
20.	FE Parameter Abbreviation Descriptions	103

1. Order Information

1.1 Versatile Controller

Model		Output 1	Output 2	Alarm	TRS	Remote	COMM	Input type	Power
		1	0	1	0	0	0	0 1	A
FE400	48x48mm	0 None	0 None	0 None	0 None	0 None	0 None	See input Range type code	A AC 85~265V
FE700	72x72mm	1 Relay	1 Relay	1 1 Set	1 4~20mA	1 4~20mA	3 TTL		D DC 24V
FE800	48x96mm	2 Voltage Pulse (SSR Drive)	2 Voltage Pulse (SSR Drive)	2 2 Sets	2 0~20mA	2 0~20mA	B RS-485(Old FE)		
FE900	96x96mm	3 4~20mA	3 4~20mA	3 3 Sets	A 0~5V	A 0~5V	C RS-485		
		4 0~20mA	4 0~20mA		B 0~10V	B 0~10V			
		A 0~5V	A 0~5V		C 1~5V	C 1~5V			
		B 0~10V	B 0~10V	A HBA	D 2~10V	D 2~10V			
		C 1~5V	C 1~5V	B HBA+AL2		E DI			
		D 2~10V	D 2~10V	C HBA+AL2+AL3		F Remote + DI			

※  Block means optional functions with additional charge

※  Boxed-in items are optional functions, which shall incur extra charges

1.2 DIN Rail Controller

Model		Output 1	Output 2	Alarm	TRS	Remote	COMM	Input type	Power
		1	0	1	0	0	0	0 1	A
FE250(Plug-in-out terminal)		0 None	0 None	0 None	0 None	0 None	0 None	See input Range type code	A AC 85~265V
FE251(Fixed terminal)		1 Relay	1 Relay	1 1 Set	1 4~20mA	1 4~20mA	3 TTL		D DC 24V
FE300(Fixed terminal)		2 Voltage Pulse (SSR Drive)	2 Voltage Pulse (SSR Drive)	2 2 Sets	2 0~20mA	2 0~20mA	B RS-485(Old FE)		
		3 4~20mA	3 4~20mA	3 3 Sets	A 0~5V	A 0~5V	C RS-485		
		4 0~20mA	4 0~20mA		B 0~10V	B 0~10V			
		A 0~5V	A 0~5V		C 1~5V	C 1~5V			
		B 0~10V	B 0~10V	A HBA	D 2~10V	D 2~10V			
		C 1~5V	C 1~5V	B HBA+AL2					
		D 2~10V	D 2~10V						

※  Block means optional functions with additional charge

2. Specifications

2.1 Versatile Specification

Model		FE400	FE700	FE800	FE900
Supply Voltage		AC 85 ~ 265V, DC 24V (Optional Functions)			
Power Frequency		50/60 Hz			
Power Consumption		Approximately 6VA			
Memory		Non-Volatile Memory EEPROM			
Sensor Input ※ Please refer to Input Range Table		Accuracy : 0.1%			
		Sample time : 50ms			
		Thermocouple : (K, J, R, S, B, E, N, T, W, PL II, L)			
		RTD: PT100			
		DC Linear Analog Input: 0~20mA, 4~20mA 0~1V, 0~5V, 0~10V, 0~2V, 1~5V, 2~10V 0~25mV, 0~50mV, 0~70mV			
Output	OUT1 Relay	1a	1c	1c	1c
	OUT2 Relay	1a SPST-NO, 250 VAC, 5A (resistive load), electrical life: 100,000 operations 1c SPDT-NO, 250 VAC, 5A (resistive load), electrical life: 50,000 operations SPDT-NC, 250 VAC, 2A (resistive load), electrical life: 20,000 operations			
	SSR Driver	SPST-NO, 250 VAC, 5A (resistive load), electrical life: 100,000 operations			
	linear	ON: 24 V OFF: 0V max. load current: 20mA, with short circuit protection circuit 4~20mA, 0~20mA, 0~5V, 0~10V, 1~5V, 2~10V			
Control Method		ON-OFF or P, PI, PID control			
Alarm	Alarm 1	1a	1a	1c	1c
	Alarm 2	1a SPST-NO, 250 VAC, 5A (resistive load), electrical life: 100,000 operations 1c SPDT-NO, 250 VAC, 5A (resistive load), electrical life: 50,000 operations SPDT-NC, 250 VAC, 2A (resistive load), electrical life: 20,000 operations			
	Alarm 3	---	1a	1a	1a
TRS	Re-transmitted Signal	SPST-NO, 250 VAC, 5A (resistive load), electrical life: 100,000 operations			
	Source of Re-transmission	4~20mA, 0~20mA, 0~5V, 0~10V, 1~5V, 2~10V			
	Accuracy	SV1, PV1, MV1, SV1R, PV1R, MV1R, SV2, PV2, MV2, SV2R, PV2R, MV2R			
	Resolution	0.1%			
Remote SV	Signal	14bit			
	Resolution	4~20mA, 0~20mA, 0~5V, 0~10V, 1~5V, 2~10V			
	Controlled by	18 bit			
Digital Input		2 points			
Communication	Interface	RS-485 Half duplex Communication MAX. 31 units, MAX. distance 1200 meters			
	Protocol	Modbus RTU, TAIE			
	Parity bit	None, Odd, Even			
	Data bit	8 bit			
	Stop bit	1 or 2 bit			
	Baud rate	2400,4800,9600,19200,38400,57600,115200 bps			
Interval time		0~250ms			
Malfunction vibration		10~55 Hz 20m / s ² , for 10 min each in X, Y and Z directions.			
Vibration resistance		10~55 Hz 20m / s ² , for 2 hr each in X, Y and Z directions.			
Malfunction shock		100m / s ² , 3 times each in X, Y and Z directions.			
Shock resistance		300m / s ² , 3 times each in X, Y and Z directions.			
Operating Environment Temperature/Humidity		0 ~ 50°C (in the case of no freezing or condensatioin) / 20% ~ 90% RH			
Storage Environment Temperature		-25 ~ 65°C (in the case of no freezing or condensatioin)			
Dimension (mm)		W48 x H48 x D95	W72 x H72 x D95	W48 x H96 x D95	W96 x H96 x D95
Weight		Appox.120g	Appox.150g	Appox.170g	Appox.230g

2.1 DIN Rail Specification

Model		FE300	FE251	FE250
Terminal		Fixed terminal		Plug-in-out terminal
Supply Voltage		AC 85 ~ 265V, DC 24V (Optional Functions)		
Power Frequency		50/60 Hz		
Power Consumption		Approximately 6VA		
Memory		Non-Volatile Memory EEPROM		
Sensor Input ※ Please refer to Input Range Table		Accuracy : 0.1%		
		Sample time : 50ms		
		Thermocouple : (K, J, R, S, B, E, N, T, W, PL II, L)		
		RTD: PT100		
		DC Linear Analog Input: 0~20mA, 4~20mA 0~1V, 0~5V, 0~10V, 0~2V, 1~5V, 2~10V 0~25mV, 0~50mV, 0~70mV		
Output	OUT1 Relay	1a	1c	
		1a SPST-NO, 250 VAC, 5A (resistive load), electrical life: 100,000 operations 1c SPDT-NO, 250 VAC, 5A (resistive load), electrical life: 50,000 operations SPDT-NC, 250 VAC, 2A (resistive load), electrical life: 20,000 operations		
	OUT2 Relay SSR Driver	---	1a	
		SPST-NO, 250 VAC, 5A (resistive load), electrical life: 100,000 operations		
linear	ON: 24 V OFF: 0V max. load current: 20mA, with short circuit protection circuit			
OUT1 Relay	4~20mA,0~20mA, 0~5V,0~10V, 1~5V,2~10V			
Control Method		ON-OFF or P, PI, PID control		
Alarm	Alarm 1	1a	1c	
		1a SPST-NO, 250 VAC, 5A (resistive load), electrical life: 100,000 operations 1c SPDT-NO, 250 VAC, 5A (resistive load), electrical life: 50,000 operations SPDT-NC, 250 VAC, 2A (resistive load), electrical life: 20,000 operations		
	Alarm 2	1a SPST-NO, 250 VAC, 5A (resistive load), electrical life: 100,000 operations		
TRS	Re-transmitted Signal	4~20mA, 0~20mA, 0~5V, 0~10V, 1~5V, 2~10V		
	Source of Re-transmission	SV1, PV1, MV1, SV1R, PV1R, MV1R, SV2, PV2, MV2, SV2R, PV2R, MV2R		
	Accuracy	0.1%		
	Resolution	14bit		
Remote SV	Signal	4~20mA, 0~20mA, 0~5V, 0~10V, 1~5V, 2~10V		
	Resolution	18 bit		
	Controlled by	SV		
Commu- nication	Interface	RS-485 Half duplex Communication MAX. 31 units, MAX. distance 1200 meters		
	Protocol	Modbus RTU, TAIE		
	Parity bit	None, Odd, Even		
	Data bit	8 bit		
	Stop bit	1 or 2 bit		
	Baud rate	2400,4800,9600,19200,38400,57600,115200 bps		
Malfunction vibration		10~55 Hz 20m / s ² , for 10 min each in X, Y and Z directions.		
Vibration resistance		10~55 Hz 20m / s ² , for 2 hr each in X, Y and Z directions.		
Malfunction shock		100m / s ² , 3 times each in X, Y and Z directions.		
Shock resistance		300m / s ² , 3 times each in X, Y and Z directions.		
Operating Environment Temperature/Humidity		0 ~ 50°C (in the case of no freezing or condensatioin) / 20% ~ 90% RH		
Storage Environment Temperature		-25 ~ 65°C (in the case of no freezing or condensatioin)		
Dimension (mm)		W26 x H81 x D90	W40 x H107 x D43	
Weight		Appox.90g	Appox.105g	

3. Input Range Table

Types of input			Code	Range	
				°C	°F
Thermocouple	K	K1	01	-50.0~600.0	-58.0~999.9
		K2	02	-50~1200	-58~2192
	J	J1	03	-50.0~400.0	-58.0~752.0
		J2	04	-50~1200	-58~2192
	R	R	05	-50~1760	-58~3200
	S	S	06	-50~1760	-58~3200
	B	B	07	-50~1820	-58~3308
	E	E	08	-50~900	-58~1652
	N	N	09	-50~1300	-58~2372
	T	T1	10	-199.9~400.0	-199.9~752.0
		T2	11	-199~400	-326~752
	W	W	12	-50~2320	-58~4208
	PL	PL	13	-50~1200	-58~2192
	L	L	14	-50~800	-58~1472
RTD	PT100	PT1	15	-199.9~850.0	-199.9~999.9
		PT2	16	-199~850	-326~1562
		PT3	17	0~850	32~1562
Linear	AN1	0~25mV	18	-1.999~9.999 -19.99~99.99 -199.9~999.9 -1999~9999	
	AN2	0~50mV	19		
		0~20mA	20		
		0~1V	21		
		0~2V	22		
		0~5V	23		
		0~10V	24		
	AN3	0~70mV	25		
	AN4	4~20mA	26		
		10~50mV	27		
		1~5V	28		
2~10V		29			

4. Packing List & Label Information

4.1 Packing List Guide

FE400 Packing list :

- | |
|--|
| <ol style="list-style-type: none"> 1. Temperature Controller...1 unit 2. Mounting frame.....1 unit 3. Terminal protect cover1pcs 4. Brief manual.....1 pcs |
|--|

FE700/800/900 Packing list :

- | |
|--|
| <ol style="list-style-type: none"> 1. Temperature Controller...1 unit 2. Mounting frame.....2 unit 3. Terminal protect cover1pcs 4. Brief manual.....1 pcs |
|--|

FE250/251/300 Packing list :

- | |
|--|
| <ol style="list-style-type: none"> 1. Temperature Controller...1 unit 2. Terminal protect cover1pcs 3. Brief manual.....1 pcs |
|--|

4.2 Label Guide

4.2.1 FE400 label

NO.	Item	Description
(1)	Terminal arrangement	FE400 Terminal Wiring Diagram
(2)	Model number	FE400 model name
(3)	Serial number	SP20010941001
(4)	Input type	Controller Input Signal and Range

4.2.2 FE700 label

NO.	Item	Description
(1)	Terminal arrangement	FE700 Terminal Wiring Diagram
(2)	Model number	FE700 model name
(3)	Serial number	SP20010971001
(4)	Input type	Controller Input Signal and Range

4.2.3 FE800/900 label

NO.	Item	Description
(1)	Terminal arrangement	FE900 Terminal Wiring Diagram
(2)	Model number	FE900 model name
(3)	Serial number	SP20010991001
(4)	Input type	Controller Input Signal and Range

4.2.4 FE250 label

(1) → **FE250-30100B**

(2) → INPUT 4~20mA
0.0~1000.0

(3) → DIGITAL PID CONTROLLER
OUT1 4~20mA
SUPPLY AC 85~265V
50/60HZ 6VA
AMB.TEMP. 50 °C MAX
TAIE □ CE

(4) → RS485 (B-) (A+)
11 12 13 14 15 16 17

(5) → M/N : FE250-30100B
S/N : SP20010920010

NO.	Item	Description
(1)	Terminal arrangement	FE250 Terminal Wiring Diagram
(2)	Input type	Controller Input Signal and Range
(3)	Control output	OUT1 4~20mA
(4)	Terminal arrangement	Terminal arrangement for the FE250
(5)	Serial number	SP20010920010

4.2.5 FE251 label

(1) → **FE251-30100B**

(2) → INPUT 4~20mA
0.0~100.0

(3) → DIGITAL PID CONTROLLER
OUT1 4~20mA
SUPPLY AC 85~265V
50/60HZ 6VA
AMB.TEMP. 50 °C MAX
TAIE □ CE

(4) → RS485 (B-) (A+)
9 10 11 12 13

(5) → M/N : FE251-30100B
S/N : SP20010920010

NO.	Item	Description
(1)	Terminal arrangement	FE251 Terminal Wiring Diagram
(2)	Input type	Controller Input Signal and Range
(3)	Control output	OUT1 4~20mA
(4)	Terminal arrangement	Terminal arrangement for the FE251
(5)	Serial number	SP20010920010

4.2.6 FE300 label

(1) → **FE300-30100B**

(2) → Power Supply AC 85~265V
50/60HZ 6VA
AL1
OUT1 4~20mA

(3) → DIGITAL PID CONTROLLER
S/N : SP20010930001
AMB.TEMP. 50 °C MAX

(4) → OUT1 : 4~20mA

(5) → INPUT : 4~20mA (0.0~100.0)

TAIE MADE IN TAIWAN

NO.	Item	Description
(1)	Terminal arrangement	FE300 Terminal Wiring Diagram
(2)	Terminal arrangement	Terminal arrangement for the FE300
(3)	Serial number	SP20010930001
(4)	Control output	OUT1 4~20mA
(5)	Input type	Controller Input Signal and Range

5. Parts Description

5.1 FE Versatile

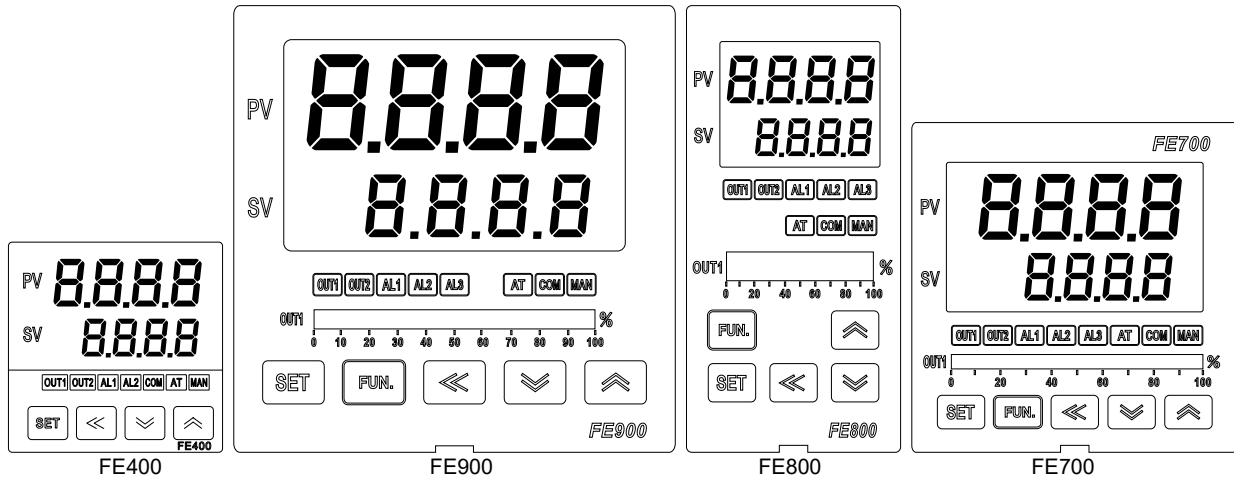

	1	PV	Indicating PV (measured value) and character information such as parameter codes or error codes(Red)	
	2	SV	Indicating SV (target set value) or parameter values(Green)	
	3	LED	OUT1	Lamp lit when OUT1 is activated (Orange)
			OUT2	Lamp lit when OUT2 is activated (Orange)
			AL1	Lamp lit when Alarm 1 is activated (Red)
			AL2	Lamp lit when Alarm 2 is activated (Red)
			AL3	Lamp lit when Alarm 3 is activated (Red)
			AT	Lamp lit when Auto-tuning is activated (Orange)
			COM	Lights when controller response data (Orange)
			MAN	Lamp lit when controller in manual mode or get error condition (Orange)
		OUT1%	OUT1% bar-graph indicator(Green)	
4	Keypad	SET	SET	For parameter call-up and set value registration
		FUN	A/M	Function activation
		<<	SHIFT	Shift digits when changing settings
		>>	DOWN	Decrease numerals
		<=	UP	Increase numerals

5.2 FE250/251

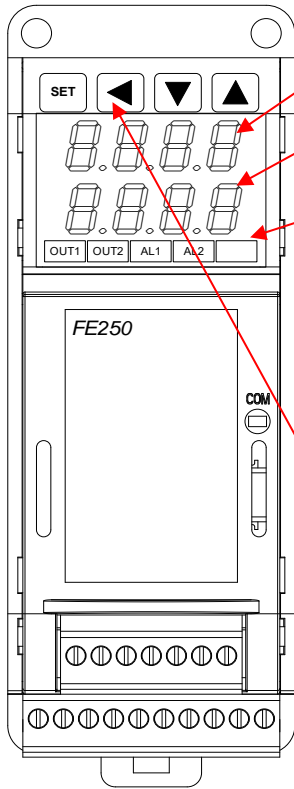

1		PV	Indicating PV (measured value) and character information such as parameter codes or error codes(Red)	
2		SV	Indicating SV (target set value) or parameter values(Green)	
3	LED	OUT1	Lamp lit when OUT1 is activated (Orange)	
		OUT2	Lamp lit when OUT2 is activated (Orange)	
		AL1	Lamp lit when Alarm 1 is activated (Red)	
		AL2	Lamp lit when Alarm 2 is activated (Red)	
			Lamp lit when Auto-tuning is activated (Orange)	
		COM	Lights when controller response data (Orange)	
4	Keypad		SET	For parameter call-up and set value registration
			SHIFT	Shift digits when changing settings
			DOWN	Decrease numerals
			UP	Increase numerals

5.3 FE300

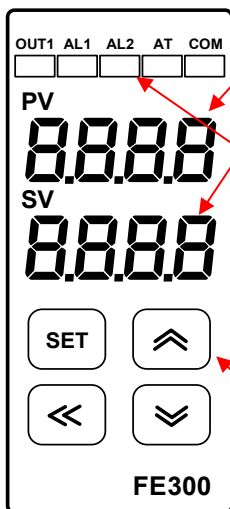

1		PV	Indicating PV (measured value) and character information such as parameter codes or error codes(Red)	
2		SV	Indicating SV (target set value) or parameter values(Green)	
3	LED	OUT1	Lamp lit when OUT1 is activated (Orange)	
		AL1	Lamp lit when Alarm 1 is activated (Red)	
		AL2	Lamp lit when Alarm 2 is activated (Red)	
		AT	Lamp lit when Auto-tuning is activated (Orange)	
		COM	Lights when controller response data (Orange)	
4	Keypad		SET	For parameter call-up and set value registration
			SHIFT	Shift digits when changing settings
			DOWN	Decrease numerals
			UP	Increase numerals

6. Installation

6.1 FE400 Dimensions

(Unit : mm)

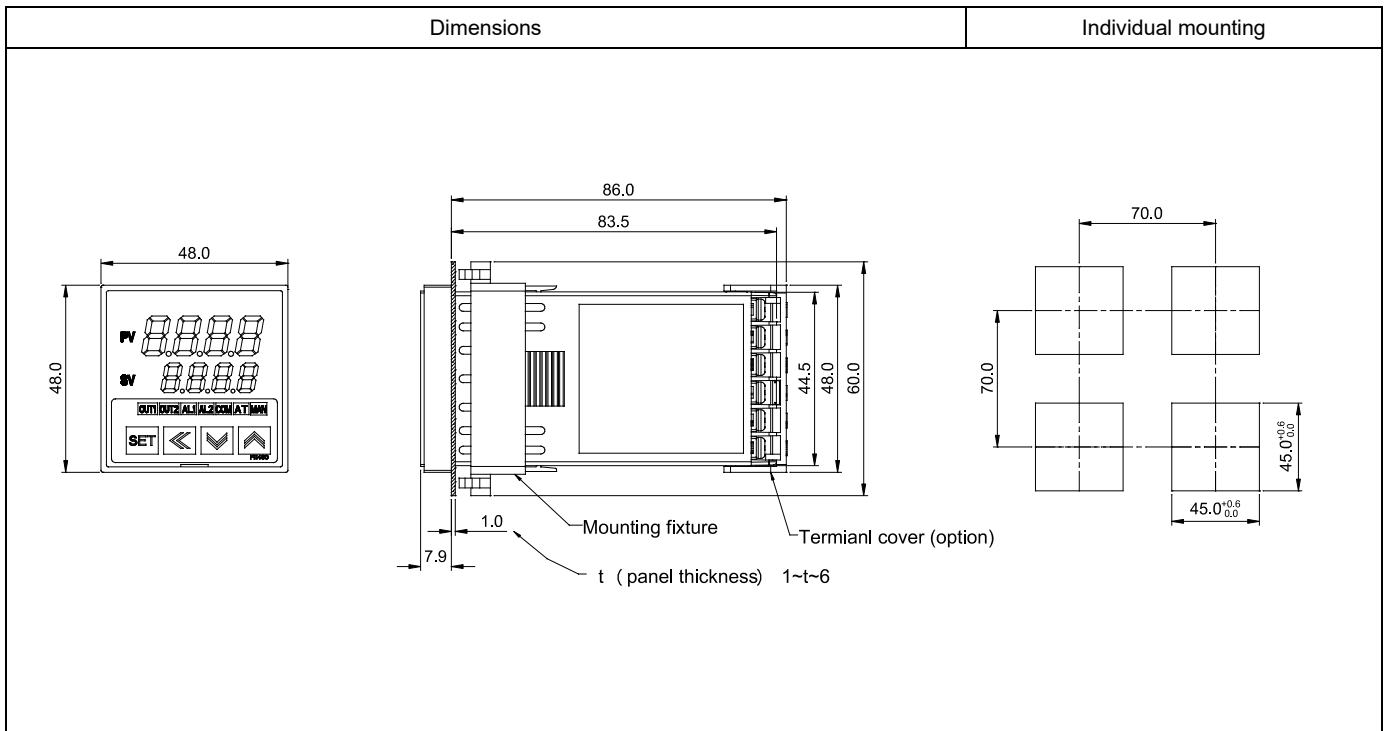

6.2 FE700 Dimensions

(Unit : mm)

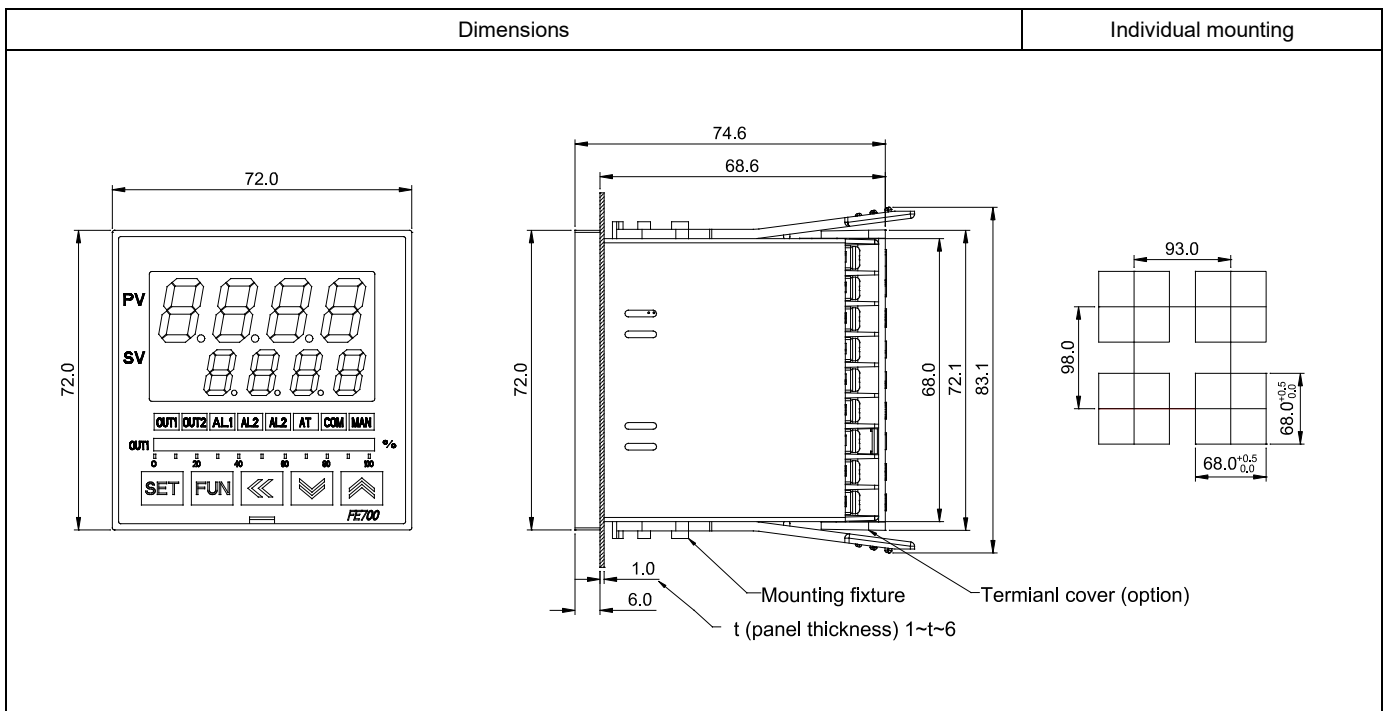

6.3 FE800 Dimensions

(Unit : mm)

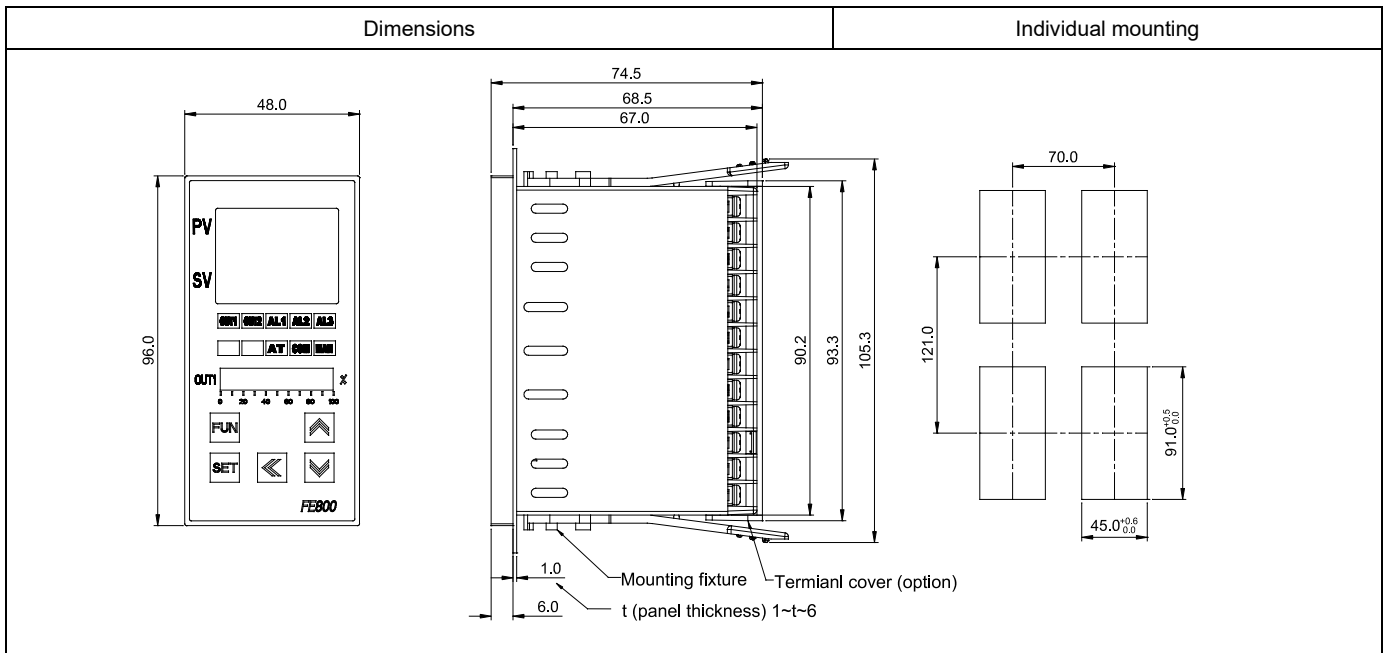

6.4 FE900 Dimensions

(Unit : mm)

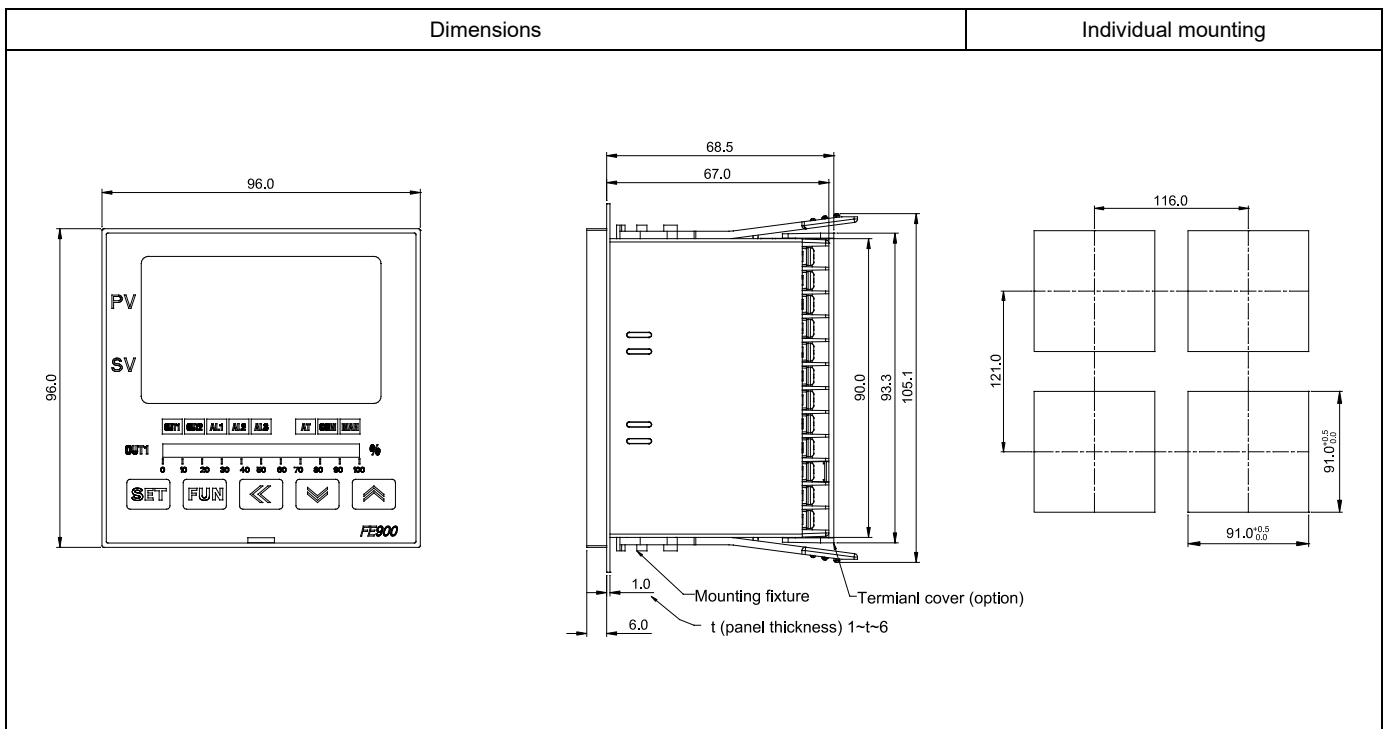

6.5 FE250/251 Dimensions

(Unit : mm)

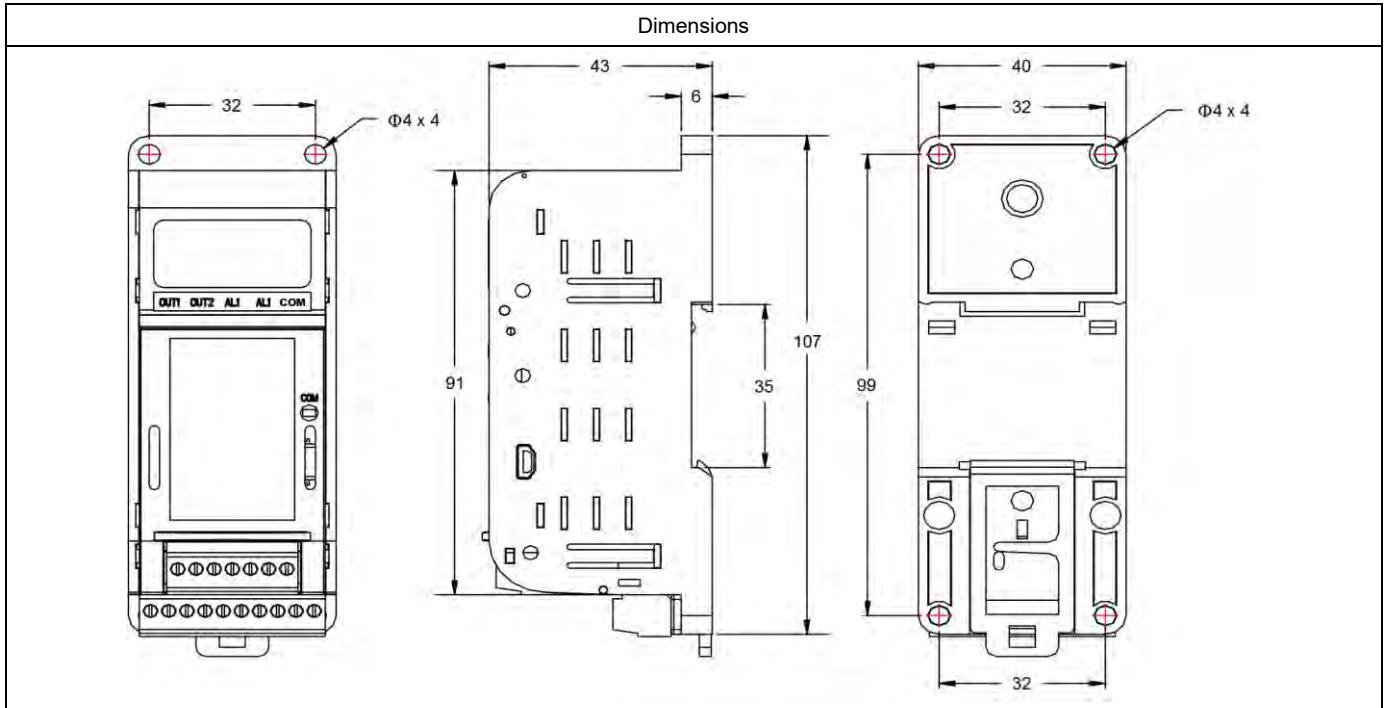

6.6 FE300 Dimensions

(Unit : mm)

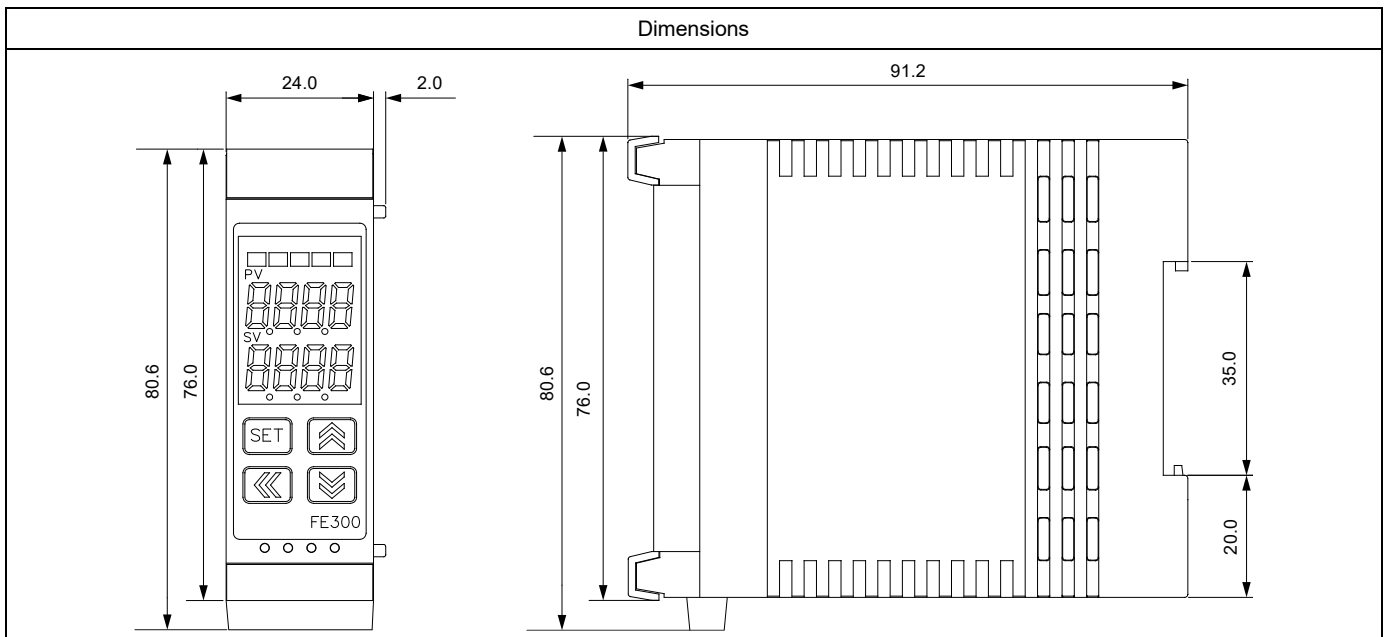

7. Terminal Arrangement

Warning

Turn the power supply to the instrument off before wiring or checking.
Working on or touching the terminal with the power switched on may result in severe injury or death due to electric shock.

7.1 FE400 Terminal Arrangement

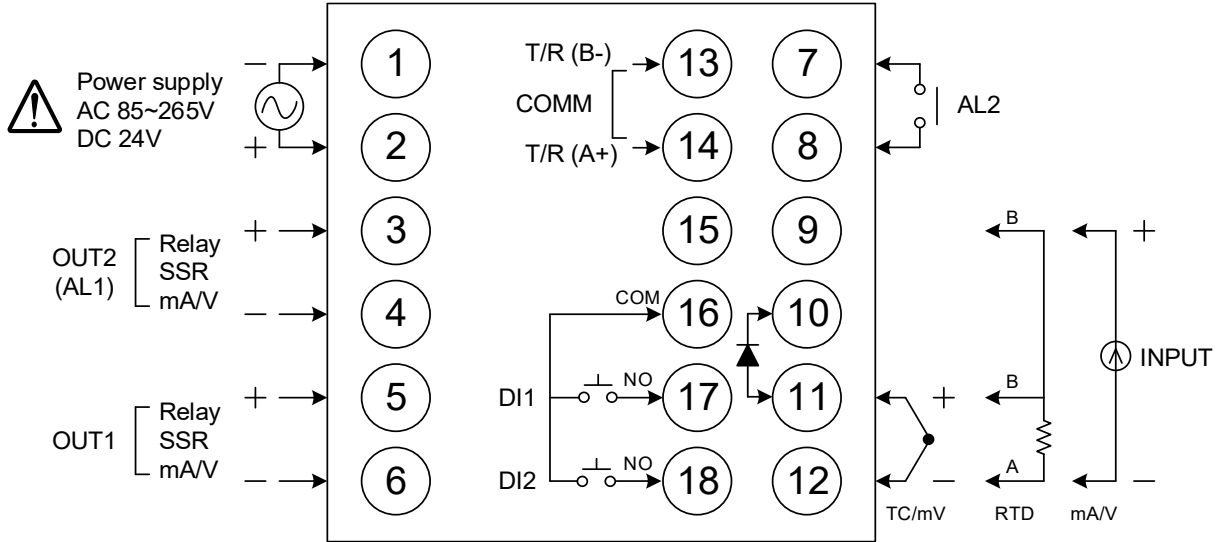

Power		Transmission	
Output-1		Remote SV / CT Input	
Output-2		Digit Input	
Alarm-1 Alarm-2		Input	
Communication			

7.2 FE700 Terminal Arrangement

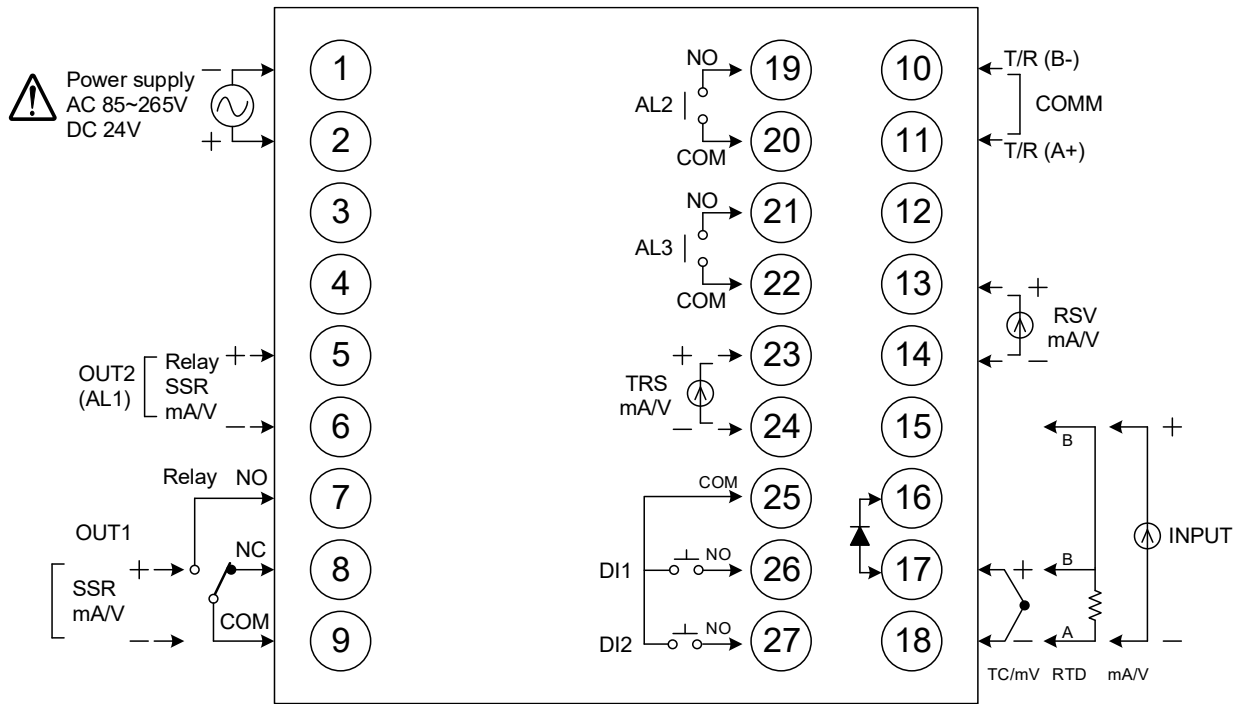

Power	<p>Terminal 1: L (AC 85~265V), - (DC 24V)</p> <p>Terminal 2: N, + (DC 24V)</p>
Output-1	<p>Terminal 7: NO</p> <p>Terminal 8: NC</p> <p>Terminal 9: COM</p> <p>Options: Relay, SSR, mA/V</p>
Output-2	<p>Terminal 5: Relay</p> <p>Terminal 6: Relay</p> <p>Options: SSR, mA/V</p>
Alarm-1 Alarm-2 Alarm-3	<p>Terminals 5, 6: AL1</p> <p>Terminals 19, 20: AL2</p> <p>Terminals 21, 22: AL3</p>
Communication	<p>Terminal 10: T/R (B-)</p> <p>Terminal 11: T/R (A+)</p> <p>RS-485</p>

Transmission	<p>Terminal 23: + (mA/V)</p> <p>Terminal 24: - (mA/V)</p>
Remote SV / CT Input	<p>Terminal 13: + (mA/V)</p> <p>Terminal 14: - (mA/V)</p> <p>Option: CT</p>
Digit Input	<p>Terminal 25: COM</p> <p>Terminal 26: NO (DI1)</p> <p>Terminal 27: NO (DI2)</p>
Input	<p>Terminal 15: B</p> <p>Terminal 17: B (RTD)</p> <p>Terminal 18: A</p> <p>Options: TC/mV, mA/V</p>

7.3 FE800 Terminal Arrangement

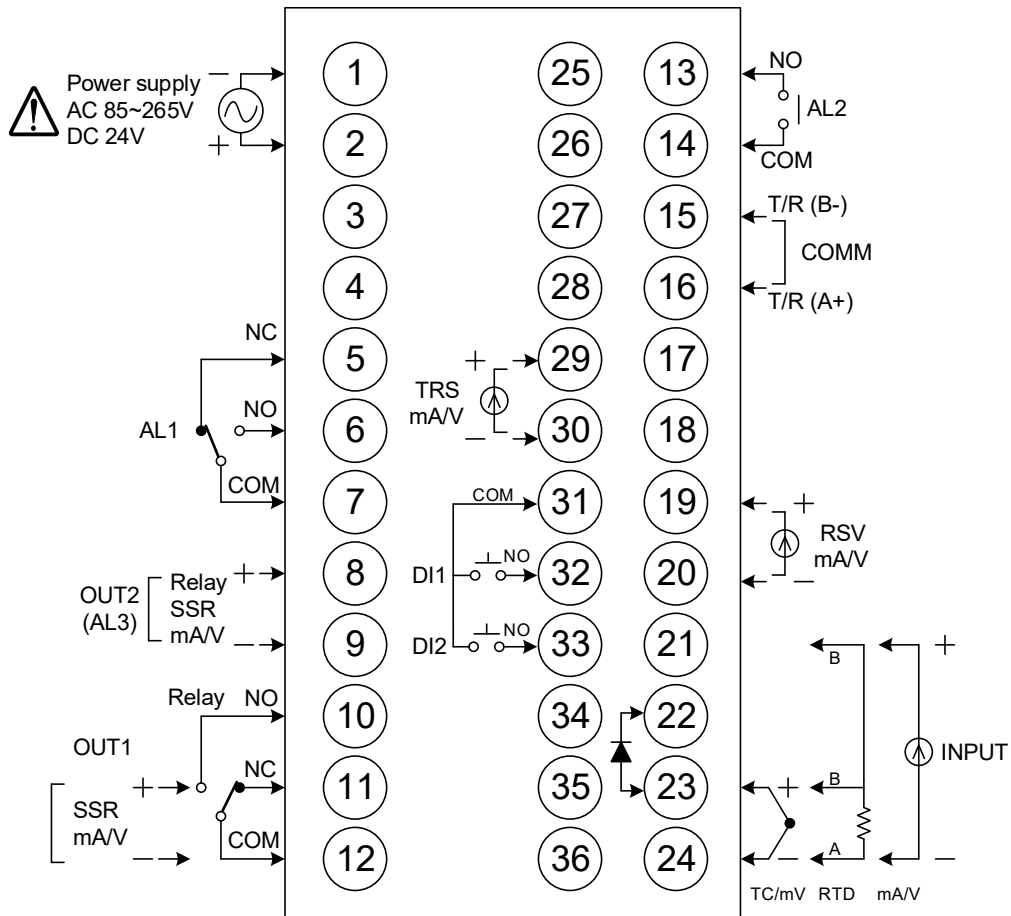

Power	
Output-1	
Output-2	
Alarm-1 Alarm-2 Alarm-3	
Communication	

Transmission	
Remote SV	
CT Input	
Digit Input	
Input	

7.4 FE900 Terminal Arrangement

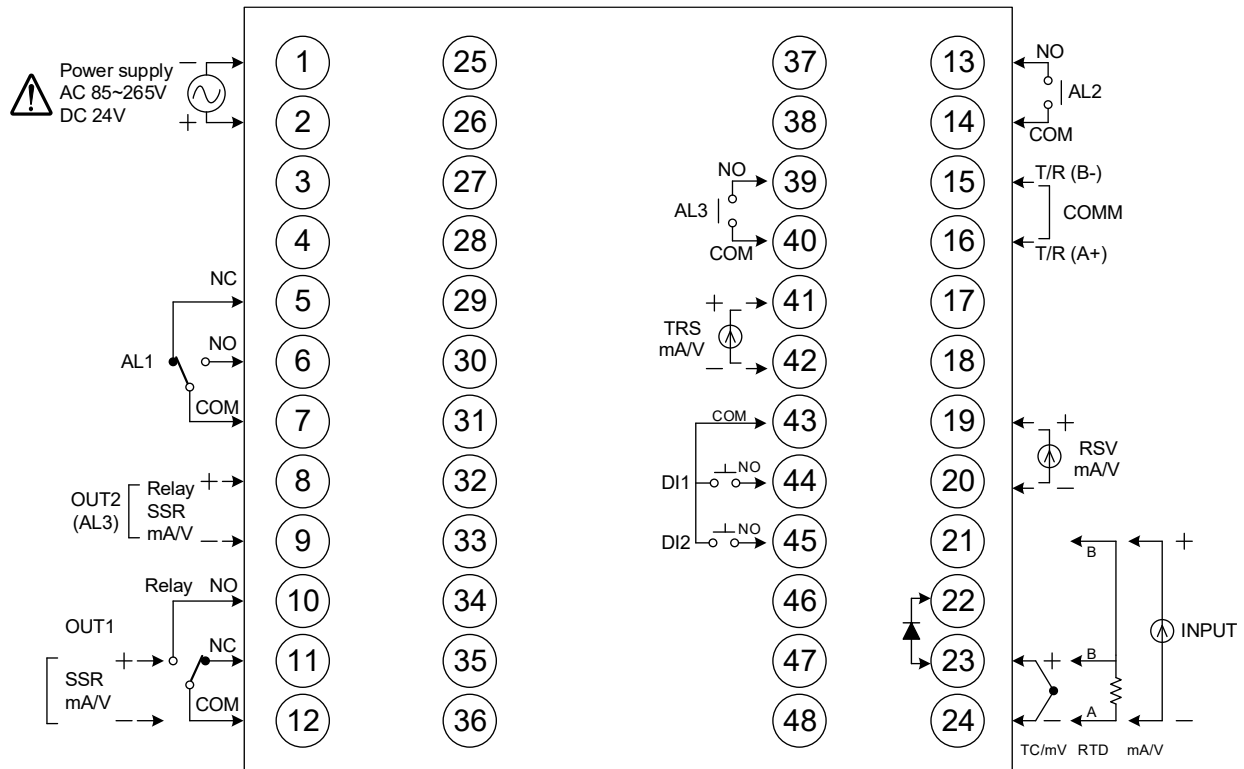

Power	
Output-1	
Output-2	
Alarm-1 Alarm-2 Alarm-3	
Communication	

Transmission	
Remote SV	
CT Input	
Digit Input	
Input	

7.5 FE250 Terminal Arrangement

Up Layer

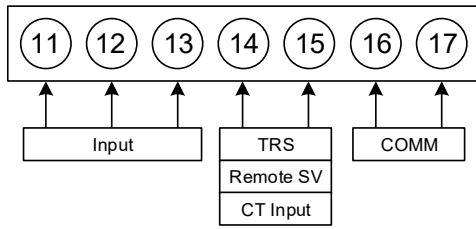

Down Layer

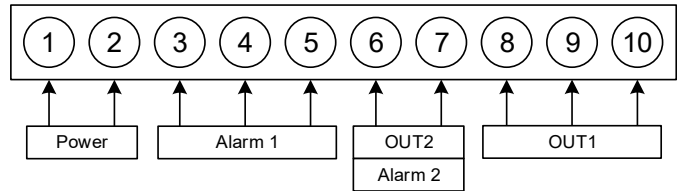

Input	
Transmission	
Remote SV / CT Input	
Communication	

Power	
Alarm-1 Alarm-2	
Output-2	
Output-1	

FE250 terminal icon

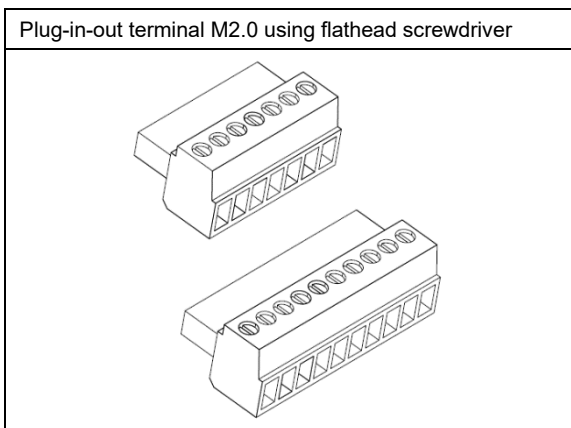

7.6 FE251 Terminal Arrangement

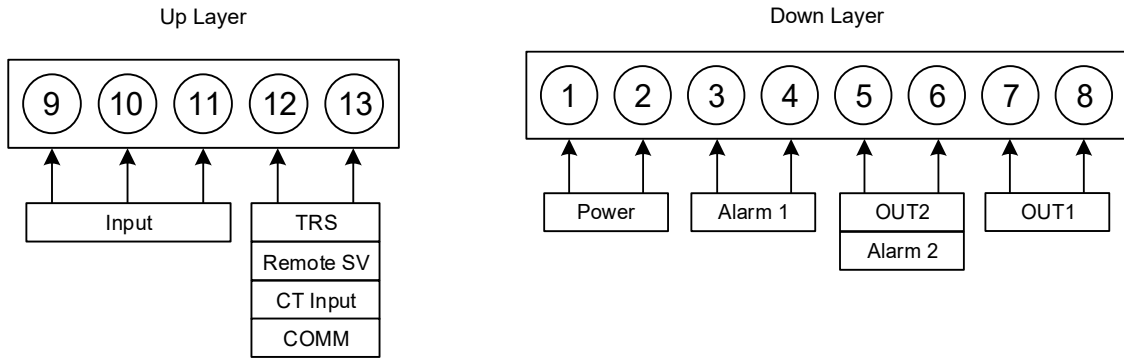

Input	<p>TC / mV: Terminals 9 and 10. RTD: Terminals 9, 10, and 11.</p>
	<p>mA / V: Terminals 9, 10, and 11.</p>
Transmission	<p>mA / V: Terminals 12 and 13.</p>
Remote SV / CT Input	<p>mA / V: Terminals 12 and 13. CT: Terminals 12 and 13.</p>
Communication	<p>RS-485: Terminals 12 (T/R (B-)) and 13 (T/R (A+)).</p>

Power	<p>AC 85~265V: Terminals 1 (L) and 2 (N). DC 24V: Terminals 1 (-) and 2 (+). Warning symbol: !</p>
Alarm-1 / Alarm-2	<p>AL1: Terminals 3 and 4. AL2: Terminals 5 and 6.</p>
Output-2	<p>Relay: Terminals 5 and 6. SSR: Terminals 5 and 6. mA / V: Terminals 5 and 6.</p>
Output-1	<p>Relay: Terminals 7 and 8. SSR: Terminals 7 and 8. mA / V: Terminals 7 and 8.</p>

FE251 terminal icon

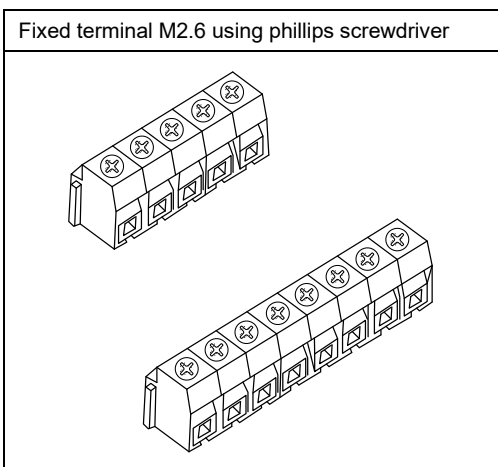

7.7 FE300 Terminal Arrangement

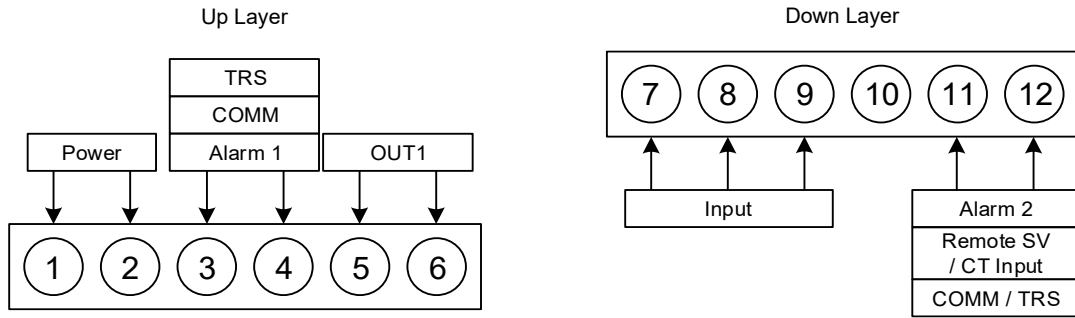

Power	<p>AC 85~265V</p> <p>DC 24V</p>
Output-1	<p>Relay</p> <p>SSR</p> <p>mA / V</p>
Transmission	<p>mA / V</p> <p>mA / V (NO Alarm)</p> <p>mA / V (NO OUTPUT)</p>
Alarm-1 Alarm-2	<p>AL1</p> <p>AL2</p>





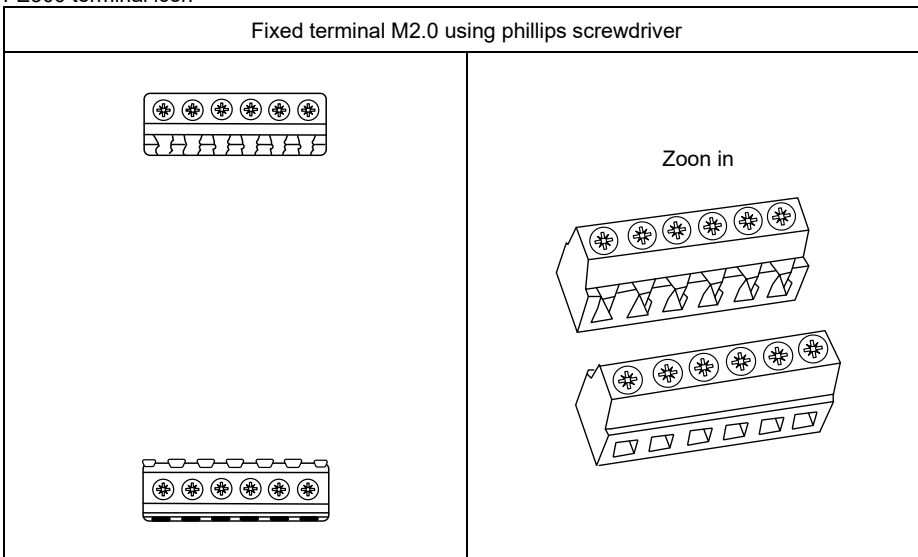











Remote SV / CT Input	<p>mA / V</p> <p>CT</p>
Communication	<p>RS-485</p> <p>T/R (B-) T/R (A+)</p> <p>RS-485 (NO Alarm)</p> <p>T/R (B-) T/R (A+)</p>
Input	<p>TC / mV</p> <p>RTD</p> <hr/> <p>mA / V</p>

FE300 terminal icon















8. Basic Function Setting

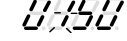











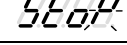

8.1 Change Input Type

1.	PV  SV 	Display after power-on.	2.	PV  SV 	Hold  key +  key 3 seconds, to enter LEVEL_3 upper display showing "INPT" with lower display showing current input type.
3.	PV  SV 	Press  key the lower display flashes.	4.	PV  SV 	Press  key and  key to enter the intended input type.
5.	PV  SV 	Press  key to store new value of INPT.	Modify input type needs to interchange of jumper location, and it needs to recalibration for linear input type change. Please refer to chapter 14 "modification of Input signal" .		

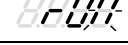













8.2 SV Setting

1.	PV  SV 	Display after power-on.	2.	PV  SV 	When  key is pressed, the lower display flashes.
3.	PV  SV 	Press  key and  key to adjust set value.	4.	PV  SV 	Press  key to store new value of SV.













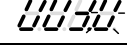

8.3 RUN/STOP Mode Selection

1.	PV  SV 	Display after power-on.	2.	PV  SV 	Press  key to enter parameter setup display, with "R_S" shown on the upper display.
3.	PV  SV 	When  key is pressed, the lower display flashes.	4.	PV  SV 	Press  key or  key to select RUN/STOP mode.
5.	PV  SV 	Press  key to store new value of R_S.	When controller is in STOP mode, it disable OUTPUT and ALARM functions.		

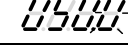















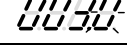

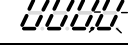







8.4 Setting PID Value Automatically(Auto-tuning)

1.	PV  SV 	Display after power-on.	2.	PV  SV 	Press  key to get parameter setup display, as "OFF" will be shown on the upper display.
3.	PV  SV 	When  key is pressed, the lower display flashes.	4.	PV  SV 	Press  key or  key to select auto tuning execution or not.
5.	PV  SV 	Press  key to store new value of AT.	When auto-tuning AT LED lamp lit and start to output, through a few circles to get new PID value with the precise control, if finished the AT LED will be lamp off.		

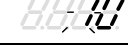

















8.5 Setting PID Value Manually

1.	PV  SV 	Display after power-on.	2.	PV  SV 	Hold  key 3 seconds, then entering LEVEL_2 upper display showing "P1", with lower display show current P1 value.
3.	PV  SV 	When  key is pressed, the lower display flashes.	4.	PV  SV 	Press  key and  key to set the intended P1 value.
5.	PV  SV 	Press  key to store new value of P1.	By the same procedure, use the same ways to set integral time(I1) and derivative time(D1).		

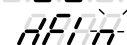



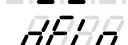







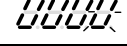

8.6 Controlling With ON/OFF Action

1.	PV  SV 	Display after power-on.	2.	PV  SV 	Hold  key 3 seconds, then entering LEVEL_2, as upper display shows "P1", with lower display showing current P1 value.
3.	PV  SV 	When  key is pressed, the lower display flashes, upper display.	4.	PV  SV 	Press  key until P1 = 0.0
5.	PV  SV 	Press  key to store new value.	6.	PV  SV 	Press  key to get parameter setup display, "HYS1" shown on the upper display.
7.	PV  SV 	When  key is pressed, the lower display flashes.	8.	PV  SV 	Press  key and  key to set the intended HYS1 value.
9.	PV  SV 	Press  key to store new value.	Heat mode formula: $PV \geq (SV + HYS1) \rightarrow OUT1 OFF$ $PV \leq (SV - HYS1) \rightarrow OUT1 ON$ Cool mode formula: $PV \geq (SV + HYS1) \rightarrow OUT1 ON$ $PV \leq (SV - HYS1) \rightarrow OUT1 OFF$		

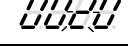























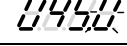

8.7 Alarm Mode Setting

1.	PV  SV 	Display after power-on.	2.	PV  SV 	Hold  key +  key 3 seconds, then entering LEVEL_3 upper display showing "INPT" with lower display showing current input type.
3.	PV  SV 	Press  key to get parameter setup display, with "ALD1" shown on the upper display.	4.	PV  SV 	When  SHIFT key is pressed, the lower display flashes.
5.	PV  SV 	Press  key and  key to set the intended ALD1 value.	6.	PV  SV 	Press  key to store new value of ALD1. Please refer to chapter 12.1 Alarm mode.

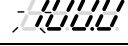
8.8 Alarm Value Setting

1.	PV  SV 	Display after power-on.	2.	PV  SV 	Press  key to get parameter setup display, with "AL1H" shown on the upper display.
3.	PV  SV 	When  key is pressed, the lower display flashes.	4.	PV  SV 	Press  key and  key to set the intended AL1H value.
5.	PV  SV 	Press  key to store new value of AL1H.			

8.9 Controlling With Manual Control

1.	PV  SV 	Display after power-on.	2.	PV  SV 	Press  key to get parameter setup display, with "A_M" shown on the upper display.
3.	PV  SV 	When  key is pressed, the lower display flashes.	4.	PV  SV 	Press  key or  key to select AUTO/MMAN mode.
5.	PV  SV 	Press  key to store new value of A_M.	6.	PV  SV 	Press  key to get parameter setup display, with "MOUT" shown on the upper display.
7.	PV  SV 	When  key is pressed, the lower display flashes.	8.	PV  SV 	Press  key and  key to set the intended MOUT value.
9.	PV  SV 	Press  key to store new value of MOUT.	In manual mode and MOUT=100.0, output=100.0% continuously. In manual mode and MOUT=20.0, output=20.0% continuously.		

9. Flow Chart Of Parameter Setting

9.1 Parameter Structure

The FE controller is an original dual-loop controller. The parameter group of Level 1~Level 4 is of LOOP type. There are two copies kept in LOOP1 and LOOP2. Level 5 parameter group non-LOOP type is of an independent, linked with Level 4 of LOOP1 or LOOP2, as the parameter structure is shown in the diagram below.

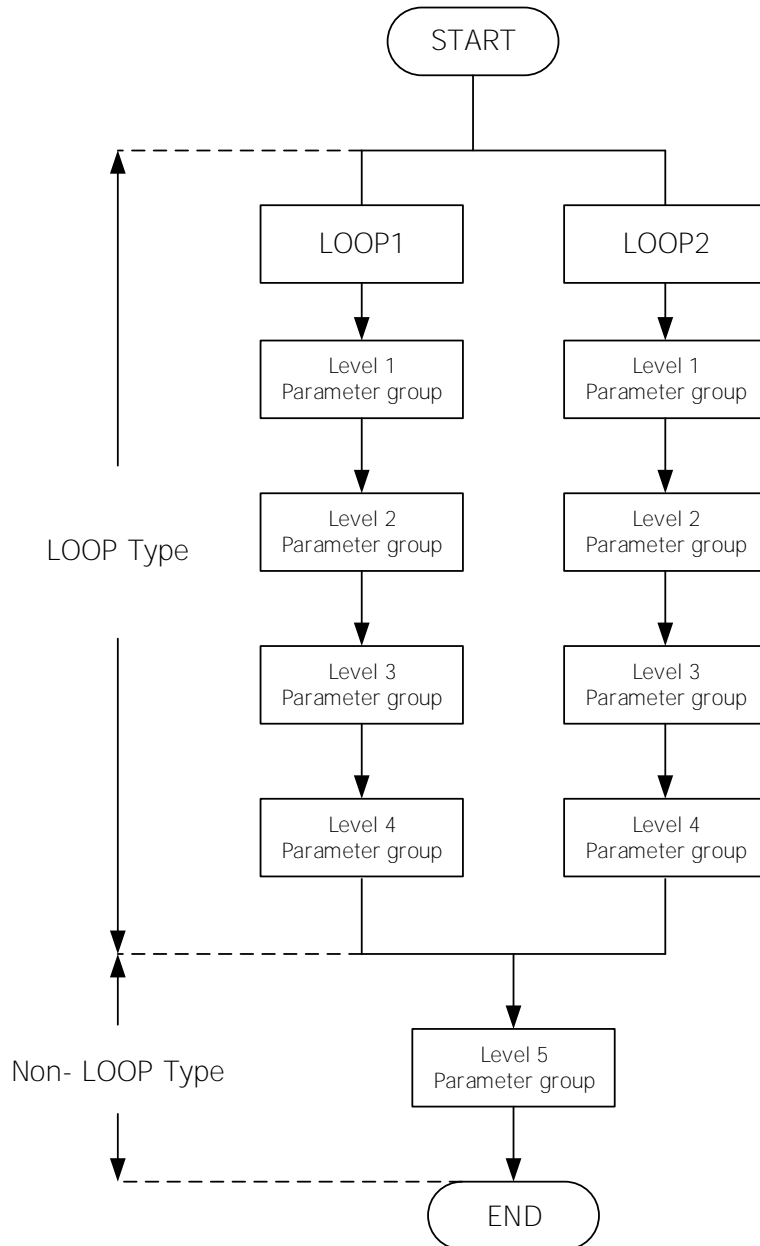

9.2 Level Operation Mode

1. LEVEL 1 enter to the LEVEL 2
Hold SET key for 3 seconds then entering into LEVEL 2
2. LEVEL 1 enter to the LEVEL 3
Hold SET key + SHIFT key for 3 seconds then entering into LEVEL 3
3. LEVEL 2 return to the LEVEL 1
Hold SET key for 3 seconds then return to LEVEL 1
4. LEVEL 2 enter to the LEVEL 3
Hold SET key for 3 seconds then return to LEVEL 3
5. LEVEL 1 enter to the LEVEL 4
Hold SET key for 3 seconds then entering into LEVEL 2, in LEVEL 2
press SET key to find parameter "LOCK", modify LOCK value from current value to 1111
then hold SET key + SHIFT key for 3 seconds then entering into LEVEL 4
6. LEVEL 2 enter to the LEVEL 5
Hold SET key for 3 seconds then entering into LEVEL 2, in LEVEL 2
press SET key to find parameter "LOCK", modify LOCK value from current value to 1000
then hold SET key + SHIFT key for 3 seconds then entering into LEVEL 5
7. LEVEL 3 return to the LEVEL 1
hold SET key + SHIFT key for 3 seconds then return to LEVEL 1
8. LEVEL 3 return to the LEVEL 2
Hold SET key for 3 seconds then return to LEVEL 2
9. LEVEL 4 return to the LEVEL 1
Hold SET key + SHIFT key for 3 seconds then return to LEVEL 1
10. LEVEL 4 return to the LEVEL 2
Hold SET key for 3 seconds then return to LEVEL 2
11. LEVEL 5 return to the LEVEL 1
Hold SET key + SHIFT key for 3 seconds then entering into LEVEL 1
12. LEVEL 5 return to the LEVEL 2
Hold SET key for 3 seconds then return to LEVEL 2

9.3 Level Operation Diagram

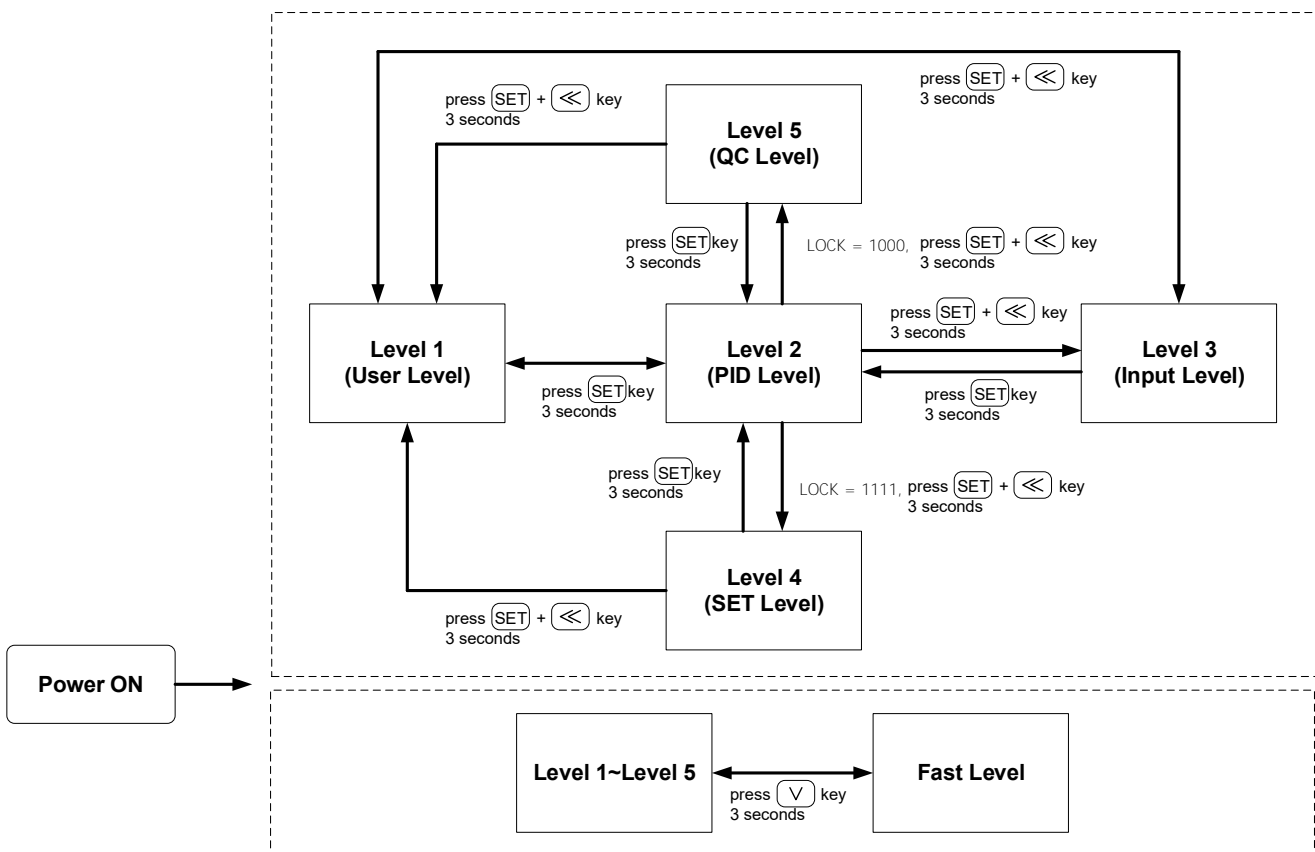

※ : If no key is pressed within 60 seconds, it will automatically return to LEVEL 1 (user level) and display PV/SV.

9.4 Data Lock Function

LOCK provides a parameter protection function to prevent the operator from touching or modifying important parameters. Conversely, when the parameter cannot be modified, please check that the set value of LCK.

LOCK	LEVEL					Descriptions
	Level_1 USER Level	Level_2 PID Level	Level_3 INPUT Level	Level_4 SET Level	Level_5 QC Level	
0000	⊙	⊙	⊙	X	X	All parameters of Level 1, 2 & 3 are able to be modified (Factory default setting)
1111	⊙	⊙	X	⊙	X	All parameters of Level 1, 2 & 4 are able to be modified
1000	⊙	⊙	X	X	⊙	All parameters of Level 1, 2 & 5 are able to be modified
0001	⊙	⊙	X	X	X	Only SV, LOOP, R_S, A_M, LOCK can be modified
0101	⊙	⊙	X	X	X	Only LOCK can be modified
0110	⊙	⊙	X	X	X	Only parameters of Level 1 and LOCK can be modified
Other	⊙	⊙	⊙	X	X	Once jumping to other levels, LOCK will be automatically restored to 0000

⊙ : allow X : inhibit

9.5 Level 1 (User Level) All Parameters Display

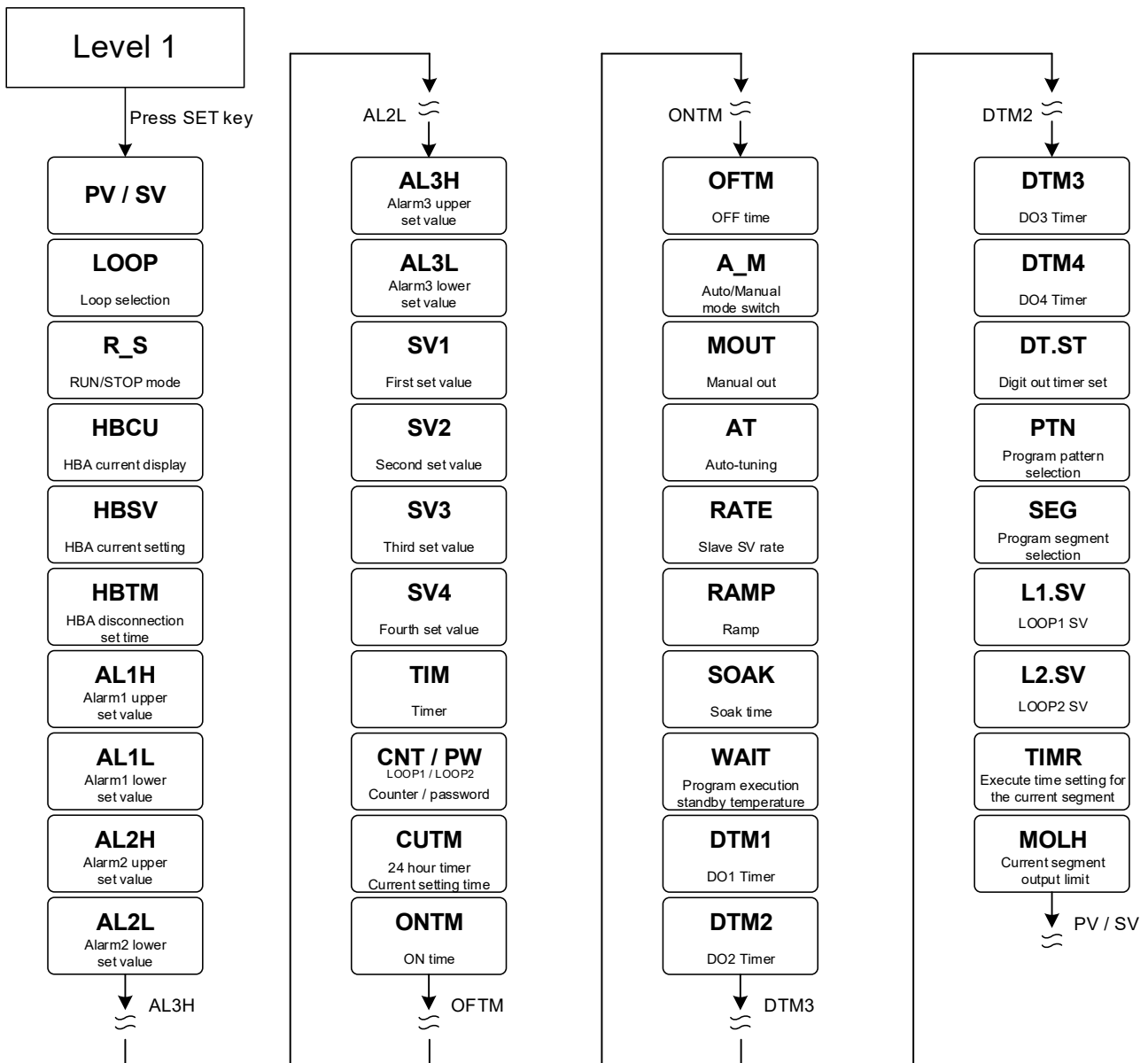

※ If no key is pressed within 60 seconds, it will automatically return to LEVEL 1 (user level) and display PV/SV.

9.6 LEVEL_1 Parameter

Parameter	Symbol	Content	Range		Default	Hide/Display
			MAX	MIN		
PV	---	Process value	USPL	LSPL	---	---
SV	---	Set value	USPL	LSPL	0	---
LOOP		Loop selection 0 : LOP1 (loop1) 1 : LOP2 (loop2)	LOP2	LOP1	LOP1	SET6.4
R_S		RUN/STOP mode selection 0 : STOP (output & alarm disable) 1 : RUN (output & alarm enable)	RUN	STOP	RUN	SET3.4
HBCU		HBA current display unit : ampere(A) Please refer to Chapter 11.4	---	---	---	SET1.1 & ALDX=HBA
HBSV		HBA current setting unit : ampere(A)	100.0	0.0	1.0	SET1.1 & ALDX=HBA
HBTM		HBA disconnection set time unit : second(S)	COTI	0.00	0.10	SET1.1 & ALDX=HBA
AL1H		Alarm1 upper set value (ALD1 = DE.HI / DE.HL / BA.ND / PR.HI / DEHI / DEHL / BAND / PRHI appear) Please refer to Chapter 12	USPL	-1999	1.0	SET1.2
AL1L		Alarm1 lower set value (ALD1 = DE.LO / DE.HL / BA.ND / PR.LO / DELO / DEHL / BAND / PRLO appear)	USPL	-1999	1.0	SET1.2
AL2H		Alarm2 upper set value (ALD2 = DE.HI / DE.HL / BA.ND / PR.HI / DEHI / DEHL / BAND / PRHI appear)	USPL	-1999	1.0	SET1.3
AL2L		Alarm2 lower set value (ALD2 = DE.LO / DE.HL / BA.ND / PR.LO / DELO / DEHL / BAND / PRLO appear)	USPL	-1999	1.0	SET1.3
AL3H		Alarm3 upper set value (ALD3 = DE.HI / DE.HL / BA.ND / PR.HI / DEHI / DEHL / BAND / PRHI appear)	USPL	-1999	1.0	SET1.4
AL3L		Alarm3 lower set value (ALD3 = DE.LO / DE.HL / BA.ND / PR.LO / DELO / DEHL / BAND / PRLO appear)	USPL	-1999	1.0	SET1.4
SV1		First set value (only available in DI function)	USPL	LSPL	10	SET2.1
SV2		Second set value (only available in DI function)	USPL	LSPL	20	SET2.1
SV3		Third set value (only available in DI function)	USPL	LSPL	30	SET2.2
SV4		Fourth set value (only available in DI function)	USPL	LSPL	40	SET2.2
TIM		Timer PV address use for current time SV address use for target time (only available in DI function) Please refer to Chapter 11.6	COTI	0.00	0.00	SET2.3
CNT		Counter PV address use for current count SV address use for target count (only available in DI function)	9999	0	0	SET2.4
CUTM		24 hour timer Current time Please refer to Chapter 11.8	23.59	0.00	0.00	SET3.1
ONTM		24 hour timer, ON time PV address use for display current time, SV address use for setting ON time	23.59	0.00	0.00	SET3.1
OFTM		24 hour timer, OFF time PV address use for display current time, SV address use for setting OFF time	23.59	0.00	0.00	SET3.1

9.6 LEVEL_1 Parameter

Parameter	Symbol	Content	Range		Default	Hide/Display
			MAX	MIN		
A_M		Auto/Manual mode switch 0 : AUTO (auto mode) 1 : MMAN (main output manual mode) 2 : SMAN (sub output manual mode)	SMAN	AUTO	AUTO	SET3.2
MOUT		Manual manipulated output setting value	100.0	0.0	0.0	SET3.2
AT		Auto-tuning execute selection 0 : OFF (PID control) 1 : ON (execute auto-tuning)	ON	OFF	OFF	SET3.3
RATE		Slave SV rate RATE SV = SV x (RATE/9999)	9999	0	9999	SV.TY=RATE SV.TY=ANRA
RAMP		The rate of change during SV ramp operation format : °C / minute Please refer to Chapter 11.10	99.99	-19.99	0.00	SV.TY=RAMP & SETE.4
SOAK		Soak time Time format : min.sec	COTI	0.00	0.10	ALDX=MSOK ALDX=SOAK ALDX=FSOK
WAIT		Program execution standby temperature 0 : when program execute do not wait for PV temperature Other values : when PV= (target SV-WAIT) program entering next segment	1000	0	0	SET4.1
DTM1		Reserve	99.59	0.00	0.00	SET4.2
DTM2		Reserve	99.59	0.00	0.00	SET4.2
DTM3		Reserve	99.59	0.00	0.00	SET4.2
DTM4		Reserve	99.59	0.00	0.00	SET4.2
DT.ST		Reserve	99.59	0.00	0.00	SET4.3
PTN		Program pattern selection 1~15	15	TRIP	1	SV.TY = PROG
SEG		Program segment selection 1~10	150	1	1	SV.TY = PROG
L1.SV		LOOP1 current segment target SV	USPL	LSPL	0	SV.TY = PROG
L2.SV		LOOP2 current segment target SV	USPL	LSPL	0	SV.TY=PROG & SET6.4
TIMR		Current segment execute time setting, this parameter determines the link between segment and segment or pattern and pattern END(-1) : program end in this segment 00.00 : program step change in this segment 00.01~99.58 : program in this segment execute time COTI(99.59) : program continue execute this segment no end	COTI	END	00.00	SV.TY = PROG
MOLH		Current segment output limit	100.0	0.0	100.0	SV.TY=PROG & SET6.4

9.7 Level 2 (PID Level) All Parameters Display

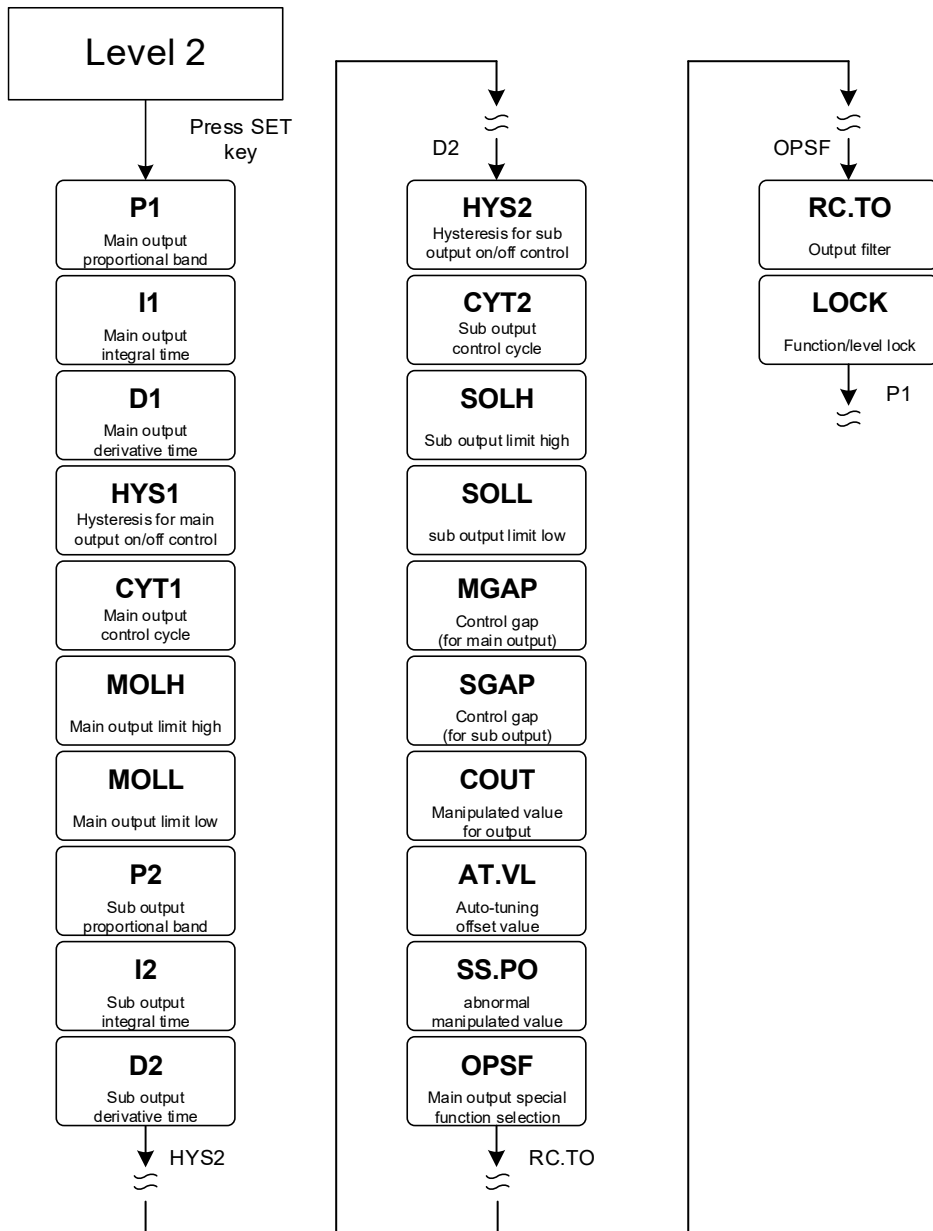



※ If no key is pressed within 60 seconds, it will automatically return to LEVEL 1 (user level) and display PV/SV.

9.8 LEVEL_2 Parameter

Parameter	Symbol	Content	Range		Default	Hide/Display
			MAX	MIN		
P1		Main output proportional band 0 : ON/OFF control Other values : proportional band setting value	200.0	0.0	3.0	---
I1		Main output integral time 0 : disable integral function Other values : integral time setting value	3600	0	240	---
D1		Main output derivative time 0 : disable derivative function Other values : derivative time setting value	900	0	60	---
HYS1		Hysteresis for main output on/off control use(when P1 = 0.0 appear) heating formula : $PV \geq (SV + HYS1) \rightarrow OUT1=OFF$ $PV \leq (SV - HYS1) \rightarrow OUT1=ON$ cooling formula : $PV \geq (SV + HYS1) \rightarrow OUT1=ON$ $PV \leq (SV - HYS1) \rightarrow OUT1=OFF$	100.0	-100.0	1.0	P1 = 0.0
CYT1		Main output control cycle 0 : Linear signal 1 : SSR drive 2~150 : Relay	150	0	10	---
MOLH		High limit setting of manipulated value for main output	100.0	0.0	100.0	SET5.2
MOLL		Low limit setting of manipulated value for main output	100.0	0.0	0.0	SET5.2
P2		Sub output proportional band 0 : ON/OFF control Other values : proportional band setting value	200.0	0.0	3.0	OU.TY = DOUB
I2		Sub output integral time 0 : disable integral function Other values : integral time setting value	3600	0	240	OU.TY = DOUB
D2		Sub output derivative time 0 : disable derivative function Other values : derivative time setting value	900	0	60	OU.TY = DOUB
HYS2		Hysteresis for sub output on/off control(when P2 = 0.0 appear)	100.0	-100.0	1.0	P2 = 0.0
CYT2		Sub output control cycle 0 : Linear signal 1 : SSR drive 2~150 : Relay	150	0	10	OU.TY = DOUB
SOLH		High limit setting of manipulated value for sub output	100.0	0.0	100.0	SET5.4
SOLL		Low limit setting of manipulated value for sub output	100.0	0.0	0.0	SET5.4
MGAP		Control gap (for main output)	1000	-1000	0	OU.TY = DOUB
SGAP		Control gap (for sub output)	1000	-1000	0	OU.TY = DOUB
COUT		Current manipulated output value	100.0	0.0	---	SET6.1
AT.VL		Auto-tuning offset value execute auto-tuning in (SV+ATVL) point	100.0	-100.0	0.0	SET6.2
SS.PO		If SETF.2=0, in manual mode or error condition controller will load this setting value as manipulated value.	100.0	0.0	25.0	SET6.2

9.8 LEVEL_2 Parameter

Parameter	Symbol	Content	Range		Default	Hide/Display
			MAX	MAX		
OPSF		Main output special function selection 0 : NONE (special function OFF) 1 : SQUA (manipulated output value square) 2 : ROOT (manipulated output value square root) 3 : REVE (manipulated output value reverse) 4 : SQ.RE (manipulated output value square reverse) 5 : RO.RE (manipulated output value square root reverse)	RO.RE	NONE	NONE	SET6.3
RC.TO		Output filter Unit : second	10.00	1.00	2.00	SET6.3
LOCK		Function/level lock Please refer to Chapter 9.4	1111	0000	0000	0000

9.9 Level 3 (Input Level) All Parameters Display

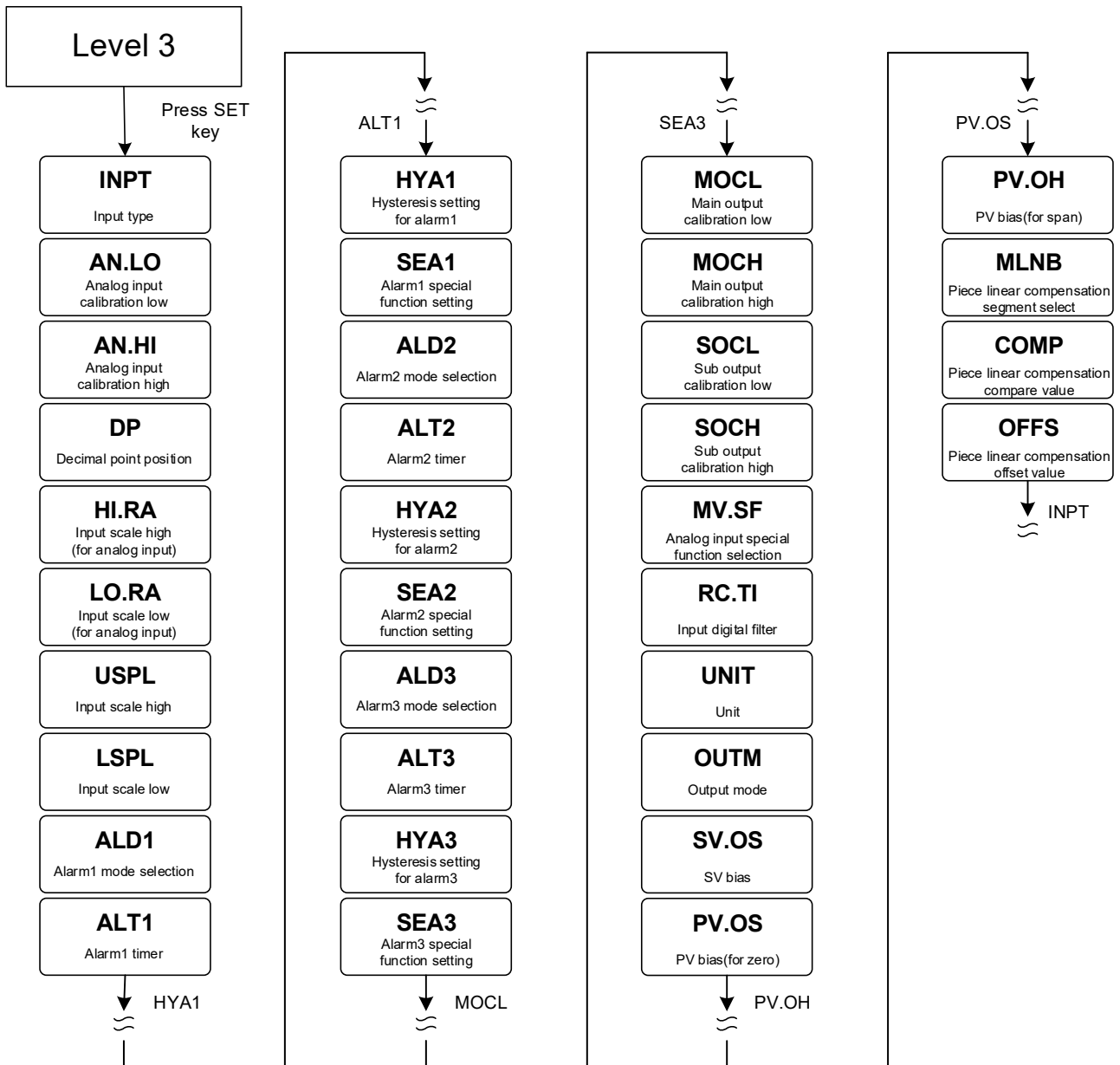

※ If no key is pressed within 60 seconds, it will automatically return to LEVEL 1 (user level) and display PV/SV.

9.10 LEVEL_3 Parameter

Parameter	Symbol	Content	Range		Default	Hide/Display
			MAX	MIN		
INPT		Input type selection (Please refer to Chapter 3 Input Range Table)	AN6	K1	K1	---
AN.LO		Analog input zero calibration, only available in linear input Please refer to Chapter 14.3	9999	-1999	0	SET7.1
AN.HI		Analog input span calibration, only available in linear input, hex display Please refer to Chapter 14.3	0x7FFF	0x0000	0x5FFF	SET7.1
DP		Decimal point position (only available in linear signal input) 0 : 0000 1 : 000.0 2 : 00.00 3 : 0.000	0.000	0000	0000	SET7.1
HI.RA		Input scale high(for analog input)	9999	-1999	---	SET7.2
LO.RA		Input scale low(for analog input)	9999	-1999	---	SET7.2
USPL		Input scale high (for Thermocouple or RTD)	9999	-1999	---	SET7.3
LSPL		Input scale low (for Thermocouple or RTD)	9999	-1999	---	SET7.3
ALD1		Alarm1 mode selection (Please refer to Chapter 12.1 Alarm Mode)	FSOK	NONE	DEHI	SET7.4
ALT1		FLIK (00.00) : Flicker COTI (99.59) : Continued ON 00.01~99.58 : delay time	COTI	FLIK	COTI	SET7.4
HYA1		Hysteresis setting for alarm1	999.9	-199.9	1.0	SET7.4
SEA1		Alarm1 special function setting (Please refer to Chapter 12.2 Alarm Special Setting)	1111	0000	0000	SET7.4
ALD2		Alarm2 mode selection (Please refer to Chapter 12.1 Alarm Mode)	FSOK	NONE	NONE	SET8.1
ALT2		FLIK (00.00) : Flicker COTI (99.59) : Continued ON 00.01~99.58 : delay time	COTI	FLIK	COTI	SET8.1
HYA2		Hysteresis setting for alarm 2	999.9	-199.9	1.0	SET8.1
SEA2		Alarm2 special function setting (Please refer to Chapter 12.2 Alarm Special Setting)	1111	0000	0000	SET8.1
ALD3		Alarm3 mode selection (Please refer to Chapter 12.1 Alarm Mode)	FSOK	NONE	NONE	SET8.2
ALT3		FLIK (00.00) : Flicker COTI (99.59) : Continued ON 00.01~99.58 : delay time	COTI	FLIK	COTI	SET8.2
HYA3		Hysteresis setting for alarm 3	999.9	-199.9	1.0	SET8.2
SEA3		Alarm3 special function setting (Please refer to Chapter 12.2 Alarm Special Setting)	1111	0000	0000	SET8.2
MOCL		Main output zero calibration only available for linear signal Please refer to Chapter 13.5	9999	0	0	SET8.3
MOCH		Main output span calibration only available for linear signal Please refer to Chapter 13.5	9999	0	3600	SET8.3
SOCL		Sub output zero calibration only available for linear signal	9999	0	0	SET8.4
SOCH		Sub output span calibration only available for linear signal	9999	0	3600	SET8.4

9.10 LEVEL_3 Parameter

Parameter	Symbol	Content	Range		Default	Hide/Display
			MAX	MIN		
MV.SF	<i>005F</i>	Analog input special function selection 0 : NONE (special function OFF) 1 : SQUA (analog input square) 2 : ROOT (analog input square root) 3 : REVE (analog input reverse) 4 : SQ.RE (analog input square reverse) 5 : RO.RE (analog input square root reverse)	RO.RE	NONE	NONE	SET9.1
RC.TI	<i>0000</i>	Input digital filter Unit : second	10.00	0.01	2.00	SET9.2
UNIT	<i>0000</i>	Unit 0 : °C 1 : °F 2 : U (Linear signal)	2	0	---	SET9.3
OUTM	<i>0000</i>	Control action selection 0 : HEAT (reverse action) 1 : COOL (direct action)	COOL	HEAT	HEAT	SET9.4
SV.OS	<i>5005</i>	SV bias	100.0	-100.0	0	SETA.1
PV.OS	<i>0005</i>	PV bias(for zero) $PV = PV \times (PV.OH / 5000) + PV.OS$ Please refer to Chapter 11.1	199.9	-199.9	0	SETA.2
PV.OH	<i>0004</i>	PV bias(for span) $PV = PV \times (PV.OH / 5000) + PV.OS$	9999	0	5000	SETA.2
MLNB	<i>0006</i>	Piece linear compensation segment select TRIP : leave setting loop 1~10 : segment select Please refer to Chapter 11.9	10	TRIP	TRIP	SETA.3
COMP	<i>0000</i>	Piece linear compensation compare value	USPL	LSPL	LSPL	SETA.3
OFFS	<i>0005</i>	Piece linear compensation offset value	150.0	-150.0	0.0	SETA.3

9.11 Level 4 (Setting Level) All Parameters Display

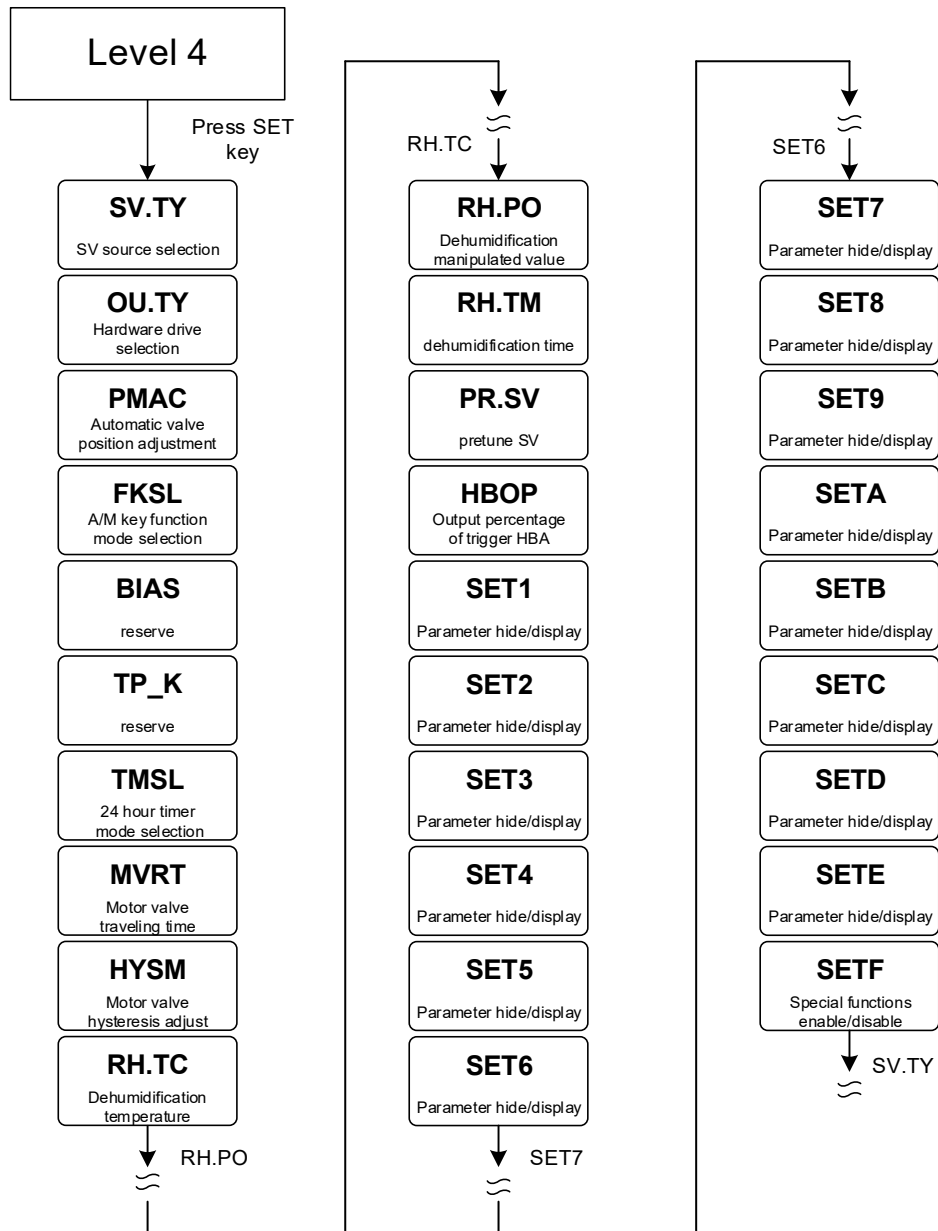

※ If no key is pressed within 60 seconds, it will automatically return to LEVEL 1 (user level) and display PV/SV.

9.12 LEVEL_4 Parameter

Parameter	Symbol	Content	Range		Default	Hide/Display
			MAX	MIN		
SV.TY		SV source selection LOOP1 0 : FIX (local SV) 1 : RATE (uart data x RATE/9999) 2 : RAMP (ramp SV) 3 : CASC (cascade control) 4 : ANAG (remote SV) 5 : ANRA (remote SV x RATE/9999) 6 : PROG (program SV) ----- LOOP2 0 : FIX (local SV) 1 : RATE (uart data x RATE/9999) 2 : RAMP (ramp SV) 3 : CASC (cascade control)	PROG	FIX	FIX	---
OU.TY		Hardware drive selection LOOP1 0 : SING (single output) 1 : DOUB (dual output) 2 : 1SCR (single phase control) 3 : HLST (high low signal selection) 4 : FBMV (valve control with feedback) 5 : NFMV (valve control without feedback) ----- LOOP2 0 : SING (single output) 1 : DOUB (dual output) 2 : 1SCR (single phase control) 3 : HLST (high low signal selection) 4 : NFMV (valve control without feedback)	NFMV	SING	SING	SETB.1
PMAC		Automatic valve position adjustment 0 : OFF stop automatic adjust 1 : ON start automatic adjust 2 : E_PB Valve position determined by external button	E_PB	OFF	OFF	OU.TY = FBMV
FKSL		FUN key function mode selection 0 : OFF (disable A/M key) 1 : R_S (switch RUN/STOP) 2 : A_M (switch auto/manual) 3 : AT (ON/OFF auto-tuning) 4 : LOOP (switch LOOP1/2) Please refer to Chapter 11.5	LOOP	OFF	A_M	SETB.3
BIAS		Reserve	1000	-1000	0	SETB.4
TP_K		Reserve	100.0	10.0	15.0	SETB.4
TMSL		24 hour timer, mode selection 0 : OFF (24 hour timer function disable) 1 : SWSV (switch SV) 2 : R_S (switch RUN/STOP) 3 : R_SO (switch to run)	R_SO	OFF	OFF	SETC.1
MVRT		Motor valve traveling time Time unit : second	150	5	5	OU.TY= FBMV & SETC.2
HYSM		Motor valve action main adjustment unit : percentage	5.0	0.0	1.0	OU.TY= FBMV & SETC.2
RH.TC		Dehumidification temperature If PV less than RHTC manipulated value = RHPO (Please refer to Chapter 11.7)	200.0	0.0	125.0	SETC.3
RH.PO		Dehumidification manipulated value 0 : OFF disable dehumidification function Other values : 0.1~100.0 manipulated value	100.0	OFF	OFF	SETC.3

9.12 LEVEL_4 Parameter

Parameter	Symbol	Content	Range		Default	Hide/Display
			MAX	MIN		
RH.TM	<i>RRR0</i>	Dehumidification time time format : min.sec	COTI	0.00	15.00	SETC.3
PR.SV	<i>RR50</i>	Reserve	USPL	LSPL	100.0	SETC.4
HBOP	<i>RRRR</i>	Output percentage of trigger HBA	100.0	0.0	90.0	SET1.1
SET1	<i>SEER1</i>	Parameters Hide/Display	4369	0	---	---
SET2	<i>SEER2</i>	Parameters Hide/Display	4369	0	---	---
SET3	<i>SEER3</i>	Parameters Hide/Display	4369	0	---	---
SET4	<i>SEER4</i>	Parameters Hide/Display	4369	0	---	---
SET5	<i>SEER5</i>	Parameters Hide/Display	4369	0	---	---
SET6	<i>SEER6</i>	Parameters Hide/Display	4369	0	---	---
SET7	<i>SEER7</i>	Parameters Hide/Display	4369	0	---	---
SET8	<i>SEER8</i>	Parameters Hide/Display	4369	0	---	---
SET9	<i>SEER9</i>	Parameters Hide/Display	4369	0	---	---
SETA	<i>SEER A</i>	Parameters Hide/Display	4369	0	---	---
SETB	<i>SEER B</i>	Parameters Hide/Display	4369	0	---	---
SETC	<i>SEER C</i>	Parameters Hide/Display	4369	0	---	---
SETD	<i>SEER D</i>	Parameters Hide/Display	4369	0	---	---
SETE	<i>SEER E</i>	Parameters Hide/Display	4369	0	---	---
SETF	<i>SEER F</i>	Parameters Hide/Display	4369	0	---	---

9.13 Level 5 (Quality Control) All Parameters Display

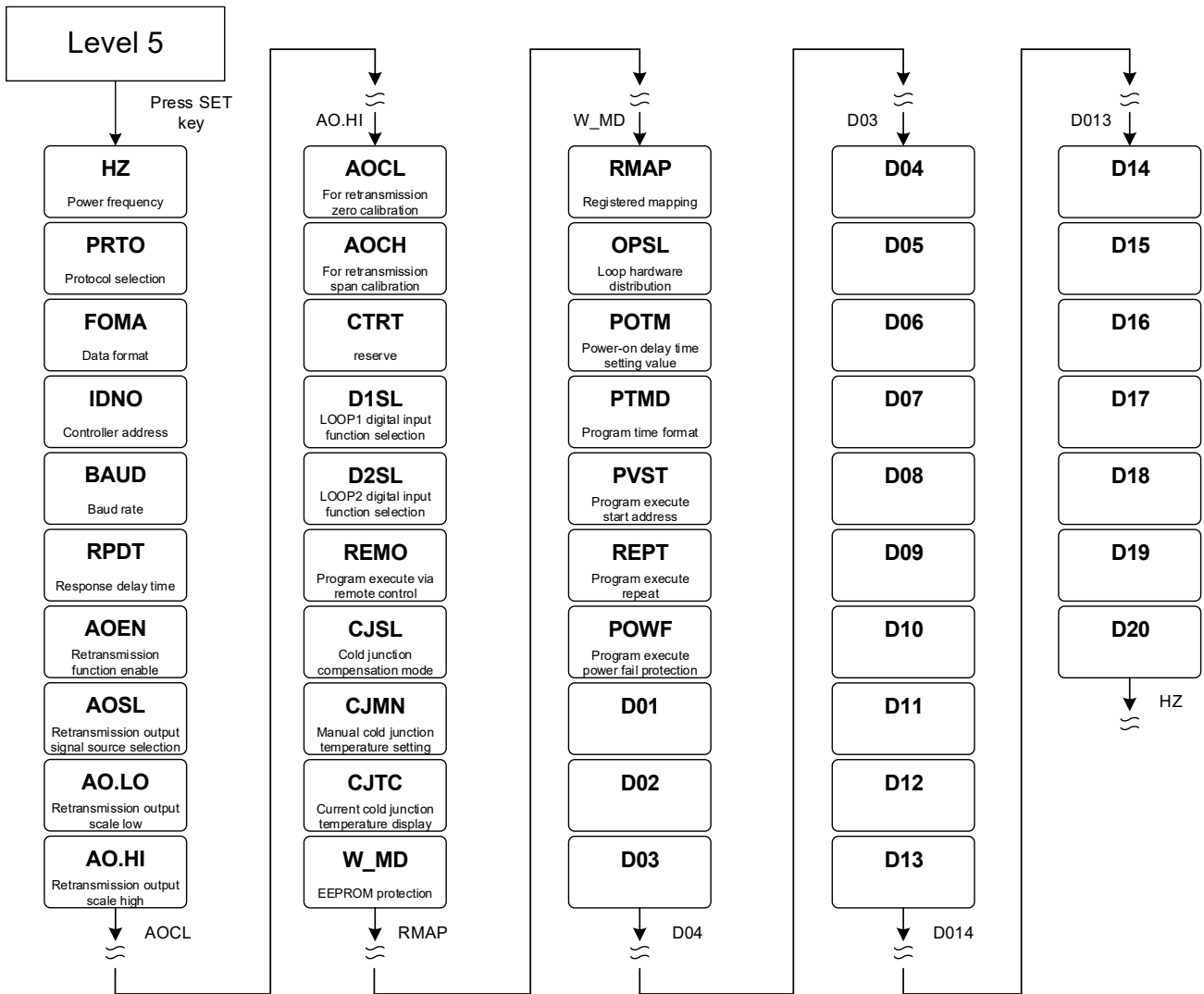









※ If no key is pressed within 60 seconds, it will automatically return to LEVEL 1 (user level) and display PV/SV.

9.14 LEVEL_5 Parameter

Parameter	Symbol	Content	Range		Default	Hide/Display
			MAX	MIN		
HZ		Power frequency 0 : 50HZ 1 : 60HZ	60HZ	50HZ	60HZ	---
PRT0		Protocol selection 0 : TAIE 1 : MRTU (Please refer to Communication Manual)	MRTU	TAIE	MRTU	SETD.1
FOMA		Data format 0 : O_81 (parity bit=odd, stop bit=1) 1 : O_82 (parity bit=odd, stop bit=2) 2 : E_81 (parity bit=even, stop bit=1) 3 : E_82 (parity bit=even, stop bit=2) 4 : N_81 (parity bit=none, stop bit=1) 5 : N_82 (parity bit=none, stop bit=2)	N_82	O_81	O_81	SETD.1
IDNO		Controller address	254	0	1	SETD.1
BAUD		Baud rate 0 : 24(2400) 1 : 48(4800) 2 : 96(9600) 3 : 192(19200) 4 : 384(38400) 5 : 576(57600) 6 : 1152(115200) bps	1152	24	384	SETD.1
RPDT		Response delay time(ms) When controller receive master command will delay this setting value then response master	250	0	0	SETD.1
AOEN		Retransmission function enable 0 : OFF (Disable) 1 : ON (Enable) (Please refer to Chapter 11.2)	ON	OFF	OFF	SETD.2
AOSL		Retransmission output signal source selection 0 : SV1 (Loop1 SV) 1 : PV1 (Loop1 PV) 2 : MV1 (Loop1 main out manipulated value) 3 : SV1R (Loop1 SV reverse) 4 : PV1R (Loop1 PV reverse) 5 : MV1R (Loop1 main out manipulated reverse value) 6 : SV2 (Loop2 SV) 7 : PV2 (Loop2 PV) 8 : MV2 (Loop2 main out manipulated value) 9 : SV2R (Loop2 SV reverse) 10 : PV2R (Loop2 PV reverse) 11 : MV2R (Loop2 main out manipulated reverse value)	MV2R	SV1	PV1	SETD.2
AO.LO		Retransmission output scale low	USPL	LSPL	LSPL	SETD.2
AO.HI		Retransmission output scale high	USPL	LSPL	USPL	SETD.2
AOCL		For retransmission zero calibration	9999	0	0	SETD.2
AOCH		For retransmission span calibration	9999	0	3600	SETD.2
CTRT		Reserve	100	1	1	SETD.3

9.14 LEVEL_5 Parameter

Parameter	Symbol	Content	Range		Default	Hide/Display
			MAX	MIN		
D1SL		LOOP1 digital input function selection 0 : OFF (disable digital input function) 1 : SWSV (switch 4 sets of SV) 2 : R_S (switch RUN/STOP) 3 : A_M (switch Auto/Manual) 4 : AT (ON/OFF auto-tuning) 5 : RESV (ON/OFF remote SV) 6 : AOEN (ON/OFF retransmission) 7 : TIM (ON/OFF timer) 8 : CNT(counter) 9 : PROG (run/reset program) (Please refer to Chapter 11.6)	PROG	OFF	OFF	SETD.3
D2SL		LOOP2 digital input function selection 0 : OFF (disable digital input function) 1 : SWSV (switch 4 sets of SV) 2 : R_S (switch RUN/STOP) 3 : A_M (switch Auto/Manual) 4 : AT (ON/OFF auto-tuning) 5 : RESV (ON/OFF remote SV) 6 : AOEN (ON/OFF retransmission) 7 : TIM (ON/OFF timer) 8 : CNT(counter)	CNT	OFF	OFF	SETD.3
REMO		Program execute via remote control OFF : program execute by key ON : program execute by digital input or communication	ON	OFF	OFF	SETD.4
CJSL		Cold junction compensation mode selection 0 : AUTO (auto cold junction compensation) 1 : MAN (manual cold junction compensation)	MAN	AUTO	AUTO	SETE.1
CJMN		Manual cold junction temperature setting	50.0	-10.0	25	SETE.1
CJTC		Current cold junction temperature display	---	---	---	SETE.1
W_MD		EEPROM protection 0 : OFF communication write command only write to CPU RAM 1 : ON communication write command write to CPU RAM and EEPROM	ON	OFF	ON	SETE.1
RMAP		Registered mapping 0 : OFF (disable registered mapping) 1 : FY (mapping to FY series memory address) 2 : FE (mapping to FE series memory address) 3 : FA (mapping to FA series memory address)	5	0	0	SETE.1
OPSL		Loop hardware distribution 0 : LOP1 loop1 main out drive out1 hardware, sub out drive out2 hardware (use for dual output) 1 : LOP2 loop2 main out drive out1 hardware, sub out drive out2 hardware (use for dual output) 2 : LP12 loop1 main out drive out1 hardware, loop2 main out drive out2 hardware (use for single output)	LP12	LOP1	LP12	SETE.1

9.14 LEVEL_5 Parameter

Parameter	Symbol	Content	Range		Default	Hide/Display
			MAX	MIN		
POTM		System steady state time output and alarm function will enable after waiting for this setting value when powe-on	COTI	0.06	0.06	SETE.1
PTMD		Program time format 0 : SEC (minute.second) 1 : MIN (hour.minute) 2 : 50MS (50ms)	50MS	SEC	MIN	SV.TY=PROG
PVST		Program execute start address 0 : ZERO (execute from zero) 1 : FULT (execute from current PV, but use segment 1 fully time) 2 : CUTT (execute from current PV, cut time)	CUTT	ZERO	FULT	SV.TY=PROG
REPT		Program execute repeat 0 : OFF (disable repeat function) Other : Program execute repeat number of times	9999	OFF	OFF	SV.TY=PROG
POWF		Program execute power fail protection 0 : OFF (disable power fail protection) 1 : ON (enable power fail protection)	ON	OFF	OFF	SV.TY=PROG
D01		Reserve	32767	-32768	0	SETE.2
D02		Reserve	32767	-32768	0	SETE.2
D03		Reserve	32767	-32768	0	SETE.2
D04		Reserve	32767	-32768	0	SETE.2
D05		Reserve	32767	-32768	0	SETE.2
D06		Reserve	32767	-32768	0	SETE.2
D07		Reserve	32767	-32768	0	SETE.2
D08		Reserve	32767	-32768	0	SETE.2
D09		Reserve	32767	-32768	0	SETE.2
D10		Reserve	32767	-32768	0	SETE.2
D11		Reserve	32767	-32768	0	SETE.2
D12		Reserve	32767	-32768	0	SETE.2
D13		Reserve	32767	-32768	0	SETE.2
D14		Reserve	32767	-32768	0	SETE.2
D15		Reserve	32767	-32768	0	SETE.2
D16		Reserve	32767	-32768	0	SETE.2
D17		Reserve	32767	-32768	0	SETE.2
D18		Reserve	32767	-32768	0	SETE.2
D19		Reserve	32767	-32768	0	SETE.2
D20		Reserve	32767	-32768	0	SETE.2

9.15 Fast Parameter Access

FE controller provides a fast parameter access operation, easy for users to quickly access communication group, program group, motor valve group related parameters

Enter fast parameter access operation: press down key for 3 seconds at any level

Leave fast parameter access operation: press down key for 3 seconds at fast level

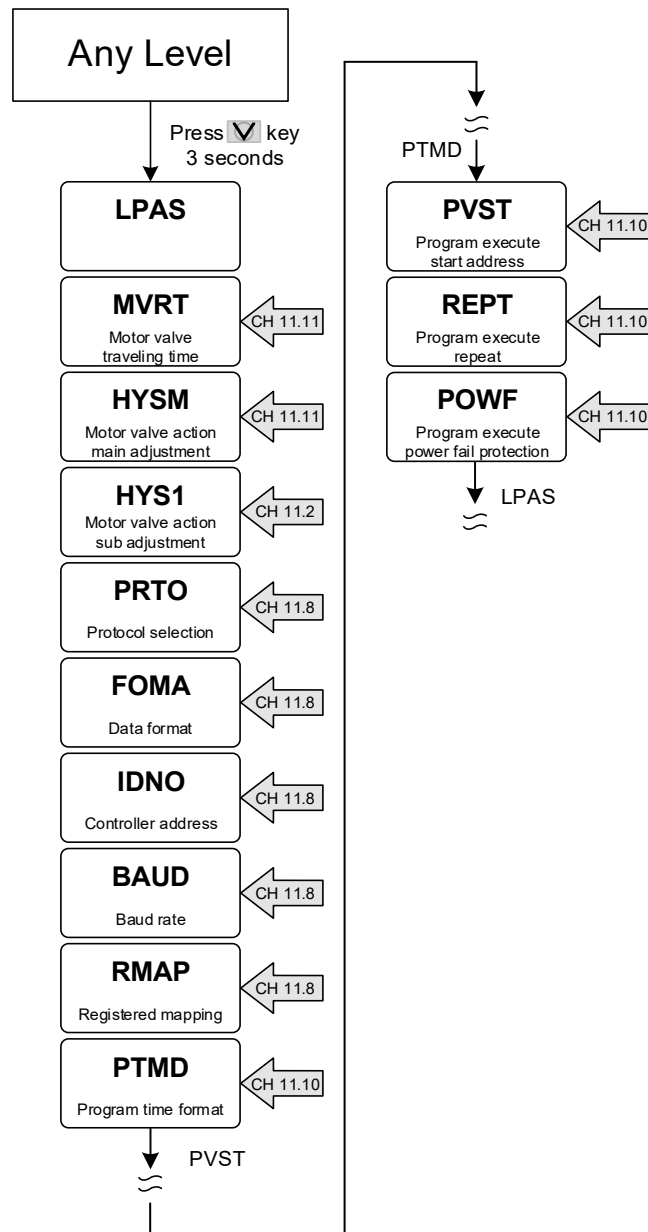

9.16 Fast Level Parameter

Parameter	Symbol	Content	Range		Default	Hide/Display
			MAX	MIN		
INPT		Input type selection (Please refer to Chapter 3 Input Range Table)	AN6	K1	K1	---
MVRT		Motor valve traveling time Time unit : second	150	5	5	OU.TY=FBMV & SETC.2
CYT1		Motor valve action interval time. Time unit : second	10	0	5	---
HYSM		Motor valve action main adjustment unit : percentage	5.0	0.0	1.0	OU.TY=FBMV & SETC.2
HYS1		Motor valve action sub adjustment unit : percentage	HYSM	0.0	0.5	OU.TY=FBMV or OU.TY=NFMV
PMAC		Automatic valve position adjustment 0 : OFF stop automatic adjust 1 : ON start automatic adjust 2 : E_PB Valve position determined by external button	E_PB	OFF	OFF	OU.TY = FBMV
RH.TC		Dehumidification temperature If PV less than RHTC manipulated value = RHPO (Please refer to Chapter 11.7)	200.0	0.0	125.0	SETC.3
RH.PO		Dehumidification manipulated value 0 : OFF disable dehumidification function Other values : 0.1~100.0 manipulated value	100.0	OFF	OFF	SETC.3
RH.TM		Dehumidification time time format : min.sec	COTI	0.00	15.00	SETC.3
PRTO		Protocol selection 0 : TAIE 1 : MRTU (Please refer to Communication Manual)	MRTU	TAIE	MRTU	SETD.1
FOMA		Data format 0 : O_81 (parity bit=odd, stop bit=1) 1 : O_82 (parity bit=odd, stop bit=2) 2 : E_81 (parity bit=even, stop bit=1) 3 : E_82 (parity bit=even, stop bit=2) 4 : N_81 (parity bit=none, stop bit=1) 5 : N_82 (parity bit=none, stop bit=2)	N_82	O_81	O_81	SETD.1
IDNO		Controller address	254	0	1	SETD.1
BAUD		Baud rate 0 : 24(2400) 1 : 48(4800) 2 : 96(9600) 3 : 192(19200) 4 : 384(38400) 5 : 576(57600) 6 : 1152(115200) bps	1152	24	384	SETD.1
RPDT		Response delay time(ms) When controller receive master command will delay this setting value then response master	250	0	0	SETD.1

9.16 Fast Level Parameter

Parameter	Symbol	Content	Range		Default	Hide/Display
			MAX	MIN		
RMAP	<i>RMAP</i>	Registered mapping 0 : OFF (disable registered mapping) 1 : FY (mapping to FY series memory address) 2 : FE (mapping to FE series memory address) 3 : FA (mapping to FA series memory address)	5	0	0	SETE.1
PTMD	<i>PTMD</i>	Program time format 0 : SEC (minute.second) 1 : MIN (hour.minute) 2 : 50MS (50ms)	50MS	SEC	MIN	SV.TY=PROG
PVST	<i>PVST</i>	Program execute start address 0 : ZERO (execute from zero) 1 : FULT (execute from current PV, but use segment 1 fully time) 2 : CUTT (execute from current PV, cut time)	CUTT	ZERO	FULT	SV.TY=PROG
REPT	<i>REPT</i>	Program execute repeat 0 : OFF (disable repeat function) Other : Program execute repeat number of times	9999	OFF	OFF	SV.TY=PROG
POWF	<i>POWF</i>	Program execute power fail protection 0 : OFF (disable power fail protection) 1 : ON (enable power fail protection)	ON	OFF	OFF	SV.TY=PROG
HBOP	<i>HBOP</i>	Output percentage of trigger HBA	100.0	0.0	90.0	SET1.1

10. Parameters Hide/Display Table On Level 4

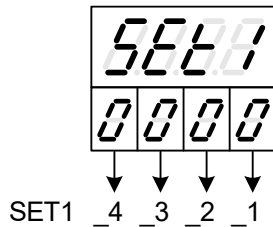

5222	SET1_1	0	hide	HBCU HBSV HBTM HBOP
		1	display	HBCU HBSV HBTM HBOP
	SET1_2	0	hide	AL1H AL1L
		1	display	AL1H AL1L
	SET1_3	0	hide	AL2H AL2L
		1	display	AL2H AL2L
	SET1_4	0	hide	AL3H AL3L
		1	display	AL3H AL3L
5222	SET2_1	0	hide	SV1 SV2
		1	display	SV1 SV2
	SET2_2	0	hide	SV3 SV4
		1	display	SV3 SV4
	SET2_3	0	hide	TIM
		1	display	TIM
	SET2_4	0	hide	(CNT→ LOOP1) (PW→ LOOP2)
		1	display	(CNT→ LOOP1) (PW→ LOOP2)
5222	SET3_1	0	hide	CUTM ONTM OFTM
		1	display	CUTM ONTM OFTM
	SET3_2	0	hide	A M
		1	display	A M
	SET3_3	0	hide	AT
		1	display	AT
	SET3_4	0	hide	R S
		1	display	R S
5222	SET4_1	0	hide	WAIT
		1	display	WAIT
	SET4_2	0	hide	DTM1 DTM2 DTM3 DTM4
		1	display	DTM1 DTM2 DTM3 DTM4
	SET4_3	0	hide	DT.ST
		1	display	DT.ST
	SET4_4	0	hide	PV1 PV2
		1	display	PV1 PV2
5222	SET5_1	0	hide	reserve
		1	display	reserve
	SET5_2	0	hide	MOLH MOLL
		1	display	MOLH MOLL
	SET5_3	0	hide	reserve
		1	display	reserve
	SET5_4	0	hide	SOLH SOLL
		1	display	SOLH SOLL
5222	SET6_1	0	hide	COUT
		1	display	COUT
	SET6_2	0	hide	AT.VL SS.PO
		1	display	AT.VL SS.PO
	SET6_3	0	hide	OPSF RC.TO
		1	display	OPSF RC.TO
	SET6_4	0	hide	LOOP L2.SV MOLH
		1	display	LOOP L2.SV MOLH
5222	SET7_1	0	hide	AN.LO AN.HI DP
		1	display	AN.LO AN.HI DP
	SET7_2	0	hide	HI.RA LO.RA
		1	display	HI.RA LO.RA
	SET7_3	0	hide	LSPL USPL
		1	display	LSPL USPL
	SET7_4	0	hide	ALD1 ALT1 HYA1 SEA1
		1	display	ALD1 ALT1 HYA1 SEA1

<i>5222</i>	SET8_1	0	hide	ALD2 ALT2 HYA2 SEA2
		1	display	ALD2 ALT2 HYA2 SEA2
	SET8_2	0	hide	ALD3 ALT3 HYA3 SEA3
		1	display	ALD3 ALT3 HYA3 SEA3
	SET8_3	0	hide	MOCL MOCH
		1	display	MOCL MOCH
	SET8_4	0	hide	SOCL SOCH
		1	display	SOCL SOCH

<i>5222</i>	SET9_1	0	hide	MV.SF
		1	display	MV.SF
	SET9_2	0	hide	RC.TI
		1	display	RC.TI
	SET9_3	0	hide	UNIT
		1	display	UNIT
	SET9_4	0	hide	OUTM
		1	display	OUTM

<i>5222</i>	SETA_1	0	hide	SV.OS
		1	display	SV.OS
	SETA_2	0	hide	PV.OS PV.OH
		1	display	PV.OS PV.OH
	SETA_3	0	hide	MLNB COMP OFFS
		1	display	MLNB COMP OFFS
	SETA_4	0	hide	Super SV function disable
		1	display	Super SV function enable

<i>5222</i>	SETB_1	0	hide	OU.TY
		1	display	OU.TY
	SETB_2	0	hide	reserve
		1	display	reserve
	SETB_3	0	hide	FKSL
		1	display	FKSL
	SETB_4	0	hide	BASE TP_K
		1	display	BASE TP_K

<i>5222</i>	SETC_1	0	hide	TMSL
		1	display	TMSL
	SETC_2	0	hide	MVRT HYSM
		1	display	MVRT HYSM
	SETC_3	0	hide	RH.TC RH.PO RH.TM
		1	display	RH.TC RH.PO RH.TM
	SETC_4	0	hide	PR.SV
		1	display	PR.SV

<i>5222</i>	SETD_1	0	hide	PRTO FOMA IDNO BAUD RPDT
		1	display	PRTO FOMA IDNO BAUD RPDT
	SETD_2	0	hide	AOEN AOSL AO.LO AO.HI AOCL AOCH
		1	display	AOEN AOSL AO.LO AO.HI AOCL AOCH
	SETD_3	0	hide	CTRTR D1SL D2SL
		1	display	CTRTR D1SL D2SL
	SETD_4	0	hide	REMO
		1	display	REMO

<i>5222</i>	SETE_1	0	hide	CJSL CJMN CJTC W MD RMAP OPST POTM
		1	display	CJSL CJMN CJTC W MD RMAP OPST POTM
	SETE_2	0	hide	D01 D02 D03 D04 D05 D06 D07
				D08 D09 D10 D11 D12 D13 D14
		1	display	D15 D16 D17 D18 D19 D20
				D01 D02 D03 D04 D05 D06 D07
	SETE_3	0	Disable Fast Level	
		1	Enable Fast Level	
	SETE_4	0	hide	RAMP
		1	display	RAMP

<i>5222</i>	SETF_1	0	valve control close Relay b contact out
		1	valve control close Relay a contact out
	SETF_2	0	in abnormal condition MOUT = SS.PO
		1	in abnormal condition MOUT = 0
	SETF_3	0	PV Hysteresis mode disable
		1	PV Hysteresis mode enable
	SETF_4	0	disable piece linear compensation function
		1	enable piece linear compensation function

11. Functional Descriptions

11.1 Input Calibration

Description

The FE series controller offers two methods for input calibration, PV bias (PV.OS) and PV ratio (PV.OH) functions to correct the deviation of each sensor, as well as PV difference between controllers.

Functional Diagram

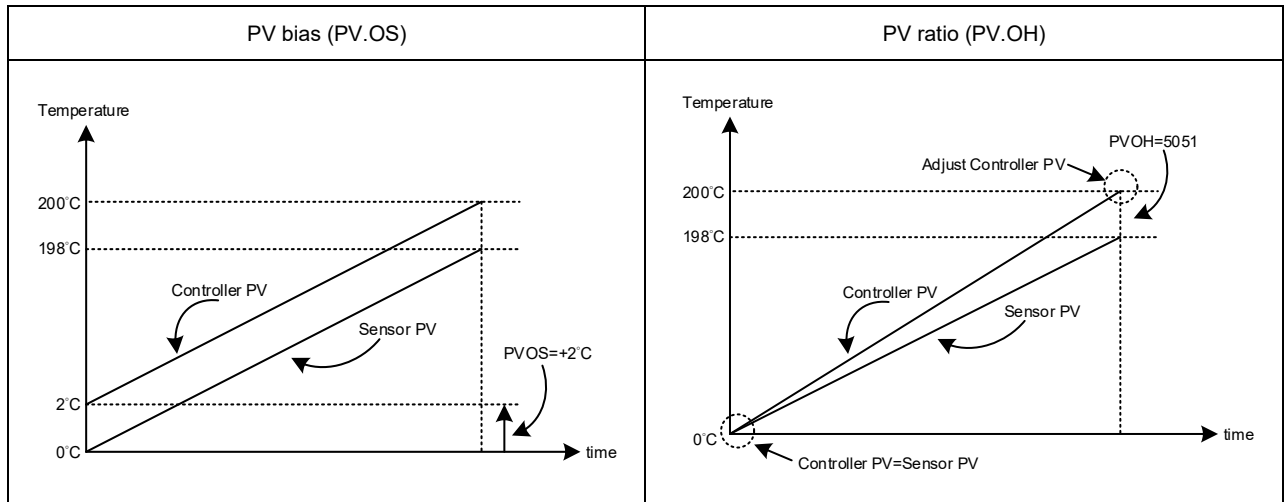

The related parameters of input calibration are as below:

Parameter	Symbol	Content	Range		Default	Level	Hide/Display
			MAX	MIN			
PV.OS	<i>PVOS</i>	PV bias(for zero) $PV = PV \times (PV.OH / 5000) + PV.OS$	199.9	-199.9	0	Level 3	SETA.2
PV.OH	<i>PVOH</i>	PV bias(for span) $PV = PV \times (PV.OH / 5000) + PV.OS$	9999	0	5000	Level 3	SETA.2

Example 1

PV bias (PV.OS) adds bias to the Measured value(PV):

When two controllers measure the temperature of the same type of load, the measured values of the respective characteristics of the sensors are displayed as

Controller A : 200°C Controller B : 195°C

As shown above, Controller B is compensated by PV offset (PV.OS). The PV.OS parameter value must be corrected by +5°C. The display value will be changed to 200°C, Same as Controller A, but Controller B will show 5°C at 0°C.

Parameter Setting

LOOP	Level	Parameter	Set value	Description
1	4	SETA.2	1	Display PV.OS / PV.OH
1	3	PV.OS	5	PV adds +5°C
1	3	PV.OH	5000	PV ratio unchanging

Example 2

PV ratio (PV.OH) is a multiplier to be applied to the Measured value(PV):

When two controllers measure the temperature of the same type of load, the measured values of the respective characteristics of the sensors are displayed as

Controller A : 200°C Controller B : 195°C

As shown above, if Controller B is compensated by the PV ratio (PV.OH), then the PV.OH parameter value is adjusted to display at 200°C. Consistent with Controller A, Controller B will show 0°C at 0°C.

Parameter Setting

LOOP	Level	Parameter	Set value	Description
1	4	SETA.2	1	Display PV.OS / PV.OH
1	3	PV.OS	0	PV bias unchanging
1	3	PV.OH	5129	$PV \text{ ratio} = (5129/5000) = 1.0258$

11.2 Retransmission

Description

The retransmission function of the FE series controller can provide digital values for parameters such as SV1, PV1, MV1, SV1R, PV1R, MV1R, SV2, PV2, MV2, SV2R, PV2R, MV2R, etc.

Analog signals are transmitted to external devices according to the set range (EX: PLC AI module, inverter, etc.).
transmission output signal selectable: 4~20mA, 0~20mA, 0~5V, 0~10V, 1~5V, 2~10V

Functional Diagram

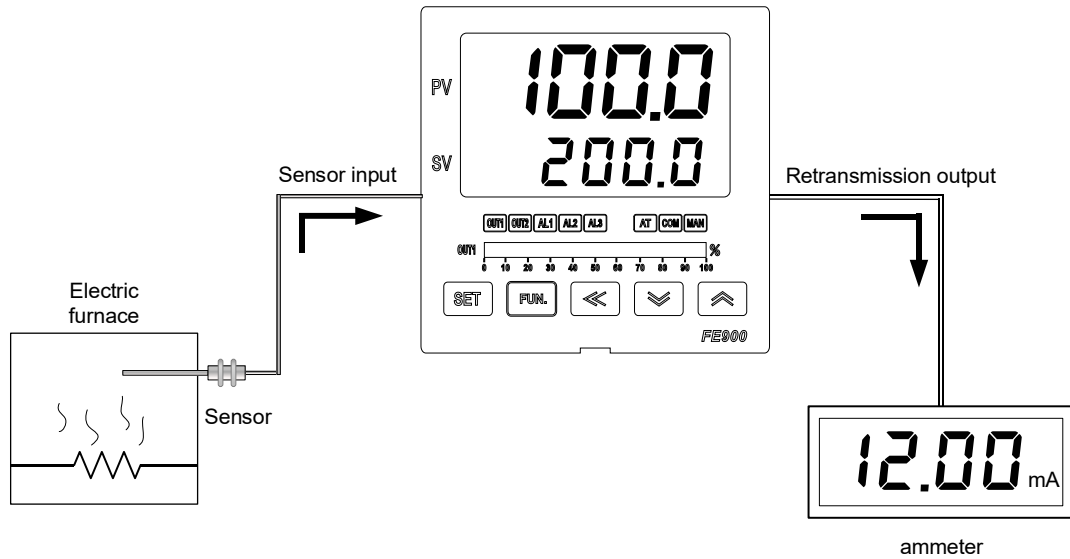

The related parameters of Transmission are as below:

Parameter	Symbol	Content	Range		Default	Level	Hide/Display
			MAX	MIN			
AOEN	<i>AOEN</i>	Retransmission function enable 0 : OFF (Disable) 1 : ON (Enable)	ON	OFF	OFF	Level 5	SETD.2
AO SL	<i>AO SL</i>	Retransmission output signal source selection 0 : SV1 (Loop1 SV) 1 : PV1 (Loop1 PV) 2 : MV1 (Loop1 main out manipulated value) 3 : SV1R (Loop1 SV reverse) 4 : PV1R (Loop1 PV reverse) 5 : MV1R (Loop1 main out manipulated reverse value) 6 : SV2 (Loop2 SV) 7 : PV2 (Loop2 PV) 8 : MV2 (Loop2 main out manipulated value) 9 : SV2R (Loop2 SV reverse) 10 : PV2R (Loop2 PV reverse) 11 : MV2R (Loop2 main out manipulated reverse value)	MV2R	SV1	PV1	Level 5	SETD.2
AO.LO	<i>AO.LO</i>	Retransmission output scale low	USPL	LSPL	LSPL	Level 5	SETD.2
AO.HI	<i>AO.HI</i>	Retransmission output scale high	USPL	LSPL	USPL	Level 5	SETD.2
AOCL	<i>AOCL</i>	For retransmission zero calibration	9999	0	0	Level 5	SETD.2
AOCH	<i>AOCH</i>	For retransmission span calibration	9999	0	3600	Level 5	SETD.2

Examples

Assume the input range (LSPL & USPL) = -50.0~600.0, and the retransmission range (AO.LO & AO.HI) = 50.0~200.0,

Retransmit PV1 (AO SL)

When the PV1 value is between 50.0 and 200.0, the retransmission signal is based on the PV1 value, the analog signal is presented.

When the PV1 is less than 50.0, the retransmission signal remains at 4mA

When the PV1 value is greater than 200.0, the retransmission signal remains at 20mA

Parameter Setting

LOOP	Level	Parameter	Set value	Description
---	5	AOEN	ON	Retransmission function enable
---	5	AOSL	PV1	Retransmit the PV
---	5	AO.LO	-50.0	Retransmission range lower limit
---	5	AO.HI	200.0	Retransmission range upper limit
---	5	AOCL	3133	Retransmission signal low point calibration value (each controller calibrate value is different)
---	5	AOCH	3508	Retransmission signal high point calibration value (each controller calibrate value is different)

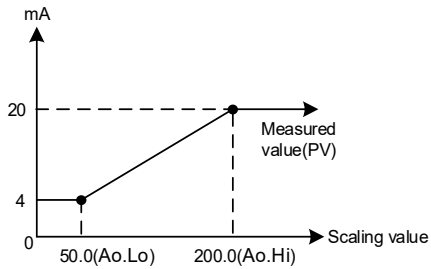

Note

1. To order TRS function, please confirm the type of retransmission output signal and retransmit signal range
2. The user can select the source to be transmitted according to the parameter AOSL. The factory default is to retransmit the PV1.
3. Modify the parameter INPT/LSPL/USPL will reset the retransmission range AO.LO / AO.HI
4. AOCL & AOCH are the calibration parameters of the re-transmission signal. It has been calibrated before leaving the factory. Do not change this parameter value.
5. The user only need to set AOSL / AO.LO / AO.HI three parameters, the rest of the parameters will be set and calibrated at the factory.

11.3 Remote SV

Description

Remote SV functions as an analog signal (4~20mA or 0~10V) generated by external devices (EX: PLC AO module, transmitter) to the Remote SV terminal of the controller, to change the SV(LOOP1) with a preset range.

Remote SV signal selection: 4~20mA, 0~20mA, 0~5V, 0~10V, 1~5V, 2~10V

Function Diagram

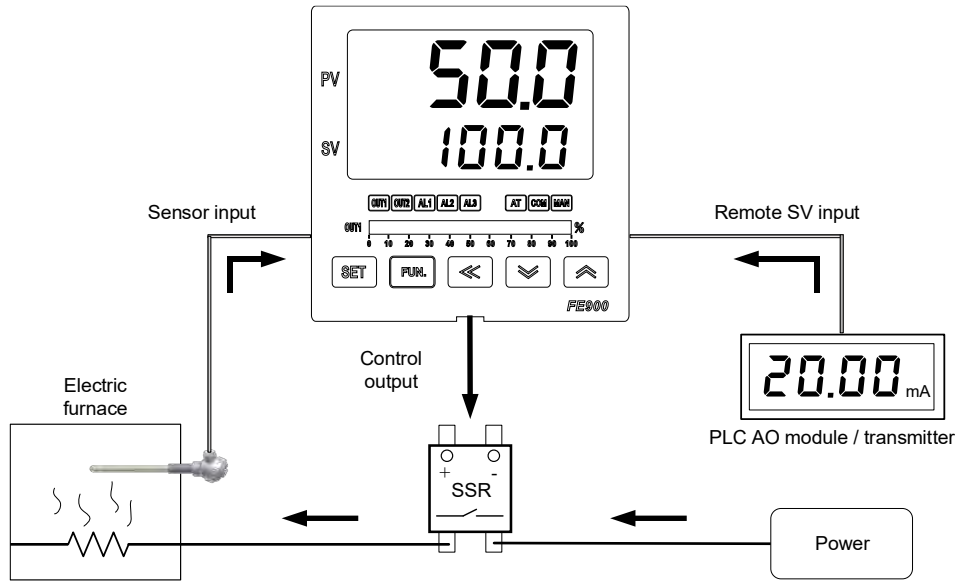

The related parameters of Remote SV are as below:

SV.TY	5888	SV source selection LOOP1 0 : FIX (local SV) 1 : RATE (uart data x RATE/9999) 2 : RAMP (ramp SV) 3 : CASC (cascade control) 4 : ANAG (remote SV) 5 : ANRA (remote SV x RATE/9999) 6 : PROG (program SV) ----- LOOP2 0 : FIX (local SV) 1 : RATE (uart data x RATE/9999) 2 : RAMP (ramp SV) 3 : CASC (cascade control)	PROG	FIX	FIX	Level 4	SETA.4
INPT	888E	Input type selection (Please refer to Chapter 3 Input Range Table)	AN6	K1	K1	Level 3	---
AN.LO	888E	Analog input zero calibration, only available in linear input (Please refer to chapter 14.3)	9999	-1999	0	Level 3	SET7.1
AN.HI	888E	Analog input span calibration, only available in linear input, hex display (Please refer to chapter 14.3)	0x7FFF	0x0000	0x5FFF	Level 3	SET7.1
DP	888E	Decimal point position (only available in linear signal input) 0 : 0000 1 : 000.0 2 : 00.00 3 : 0.000	0.000	0000	0000	Level 3	SET7.1
HI.RA	888E	Input scale high(for analog input)	9999	-1999	---	Level 3	SET7.2
LO.RA	888E	Input scale low(for analog input)	9999	-1999	---	Level 3	SET7.2

Examples

Assume LOOP1 input signal is K1 and its range is -50.0~600.0. When an external analog signal is input to the Remote SV terminal, the signal will be based on the range presents linear display of SV parameters in LOOP1

When the signal input value is less than 2.4mA, the PV position shows nnnn, indicating that the signal of Remote SV is lower than the lower limit value

When the signal input value is greater than 21.6mA, the PV position shows uuuu, indicating that the signal of Remote SV is higher than the upper limit value

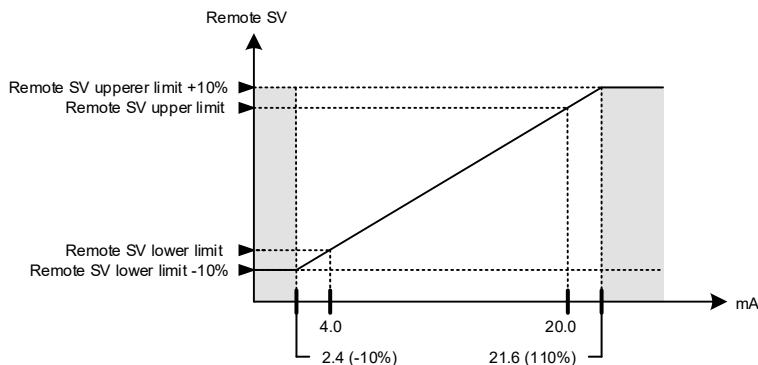

Parameter Setting

LOOP	Level	Parameter	Set value	Description
1	4	SV.TY	ANAG	SV(LOOP1) provided by external analog signal
2	3	INPT	AN4	Remote SV input signal is 4~20mA
2	3	AN.LO	744	Remote SV signal zero calibration value (each controller calibrate value is different)
2	3	AN.HI	0x657C	Remote SV signal span calibration value (each controller calibrate value is different)
2	3	HI.RA	600.0	LOOP2 input scale high (same as USPL of LOOP1)
2	3	LO.RA	-50.0	LOOP2 input scale low (same as LSPL of LOOP1)

Notes

1. To order Remote SV function, please confirm signal type and Remote SV input range first.
2. Modify the parameter INPT & UNIT will reset the input range.
3. The AN.LO and AN.HI of LOOP2 are the calibration parameters of Remote SV. It has been calibrated before leaving the factory. Please do not change this parameter.

11.4 Heater Break Alarm

Description

The HBA (Heater-Break-Alarm) function measures the heater current and displays the measured current value on the parameter HBCU so that the heater status can be monitored at any time.

When it is detected that the heater is disconnected or the heater current is abnormally reduced, an alarm message may be immediately output to notify the user.

Function Diagram

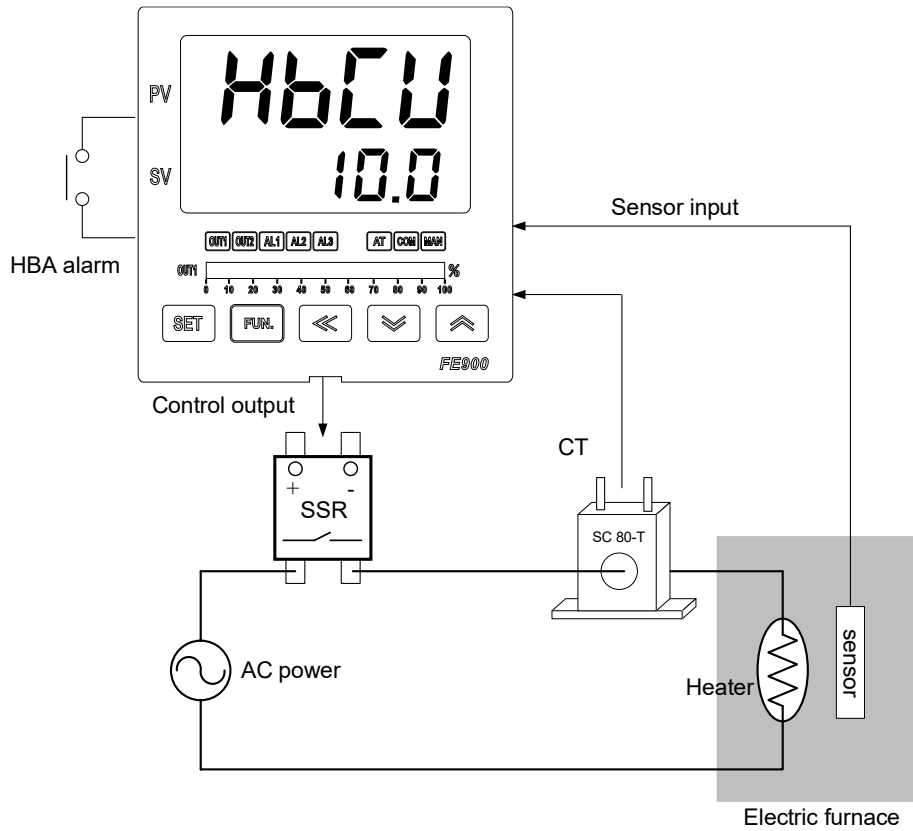

The related parameters of Heater Break Alarm are as below :

Parameter	Symbol	Content	Range		Default	Level	Hide/Display
			MAX	MIN			
HBCU	<i>HBCU</i>	HBA current display unit : ampere(A)	---	---	---	Level 1	SET1.1 & ALDX=HBA
HBSV	<i>HBSV</i>	HBA current setting unit : ampere(A)	100.0	0.0	1.0	Level 1	SET1.1 & ALDX=HBA
HBTM	<i>HBTM</i>	HBA disconnection set time unit : second(S)	5999	0	10	Level 1	SET1.1 & ALDX=HBA
HBOP	<i>HBOP</i>	Output percentage of trigger HBA	100.0	0.0	90.0	Level 4	SET1.1 & ALDX=HBA

HBA operating conditions

1. Heater current(HBCU) is less than the setting of HBSV
2. OUT1 output exceeds HBOP setting value
3. The conditions of 1 & 2 above are established and continue to exceed the set number of seconds for HBTM

Parameter Setting

LOOP	Level	Parameter	Set value	Description
1	4	SET1.1	1	Display HBCU/HBSV/HBTM
1	3	ALD1	HBA	HBA Alarm
1	1	HBCU	---	Heater Current Value Display
1	1	HBSV	1.0	HBA Action Current Set Value (unit: A)
1	1	HBTM	10	HBA Action Time Set Value (unit: Second)
1	4	HBOP	90.0	Output percentage of trigger HBA
2	3	AN.LO	-12	Current zero calibration value (each controller calibrate value is different)
2	3	AN.HI	0x4527	Current span calibration value (each controller calibrate value is different)

Examples

Heating system with SSR as control element, set HBSV=1.0, HBTM=10, HBOP=90.0

1. The heater current display value HBCU = 0.0 when a heater disconnection occurs
 → The heater current is less than the set value of HBSV=1.0. At this time, condition 1 is satisfied.
2. The heater no longer heats when the heater disconnection occurs, and the gap between the PV and SV will become larger and larger.
 → The manipulated value of OUT1 is also getting larger and larger, and eventually exceeds 90%. At this time, condition 2 is satisfied.
3. The AL1 alarm will be activated when both 1 & 2 conditions are met and continue for more than 10 seconds of the HBTM setting.

Notes

1. To order the HBA function, please confirm the control mode, only available in SSR/RELAY control linear signal (mA or V)
 Not applicable
2. AN.LO & AN.HI is the current signal calibration parameters. It has been calibrated before leaving the factory. Do not change this parameter value.
3. The user only needs to set two parameters of HBSV & HBTM & HBOP, the rest of the parameters will be set & calibrated at the factory
4. CT has two specifications: SC 80-T & SC 100-T. Please check heater wire diameter and specify required CT.

CT Specifications

Item	Specifications	
	SC 80-T	SC 100-T
Model number	SC 80-T	SC 100-T
Turns Ratio	800:1	1000:1
Max. continuous current	80A	100A
Accuracy	3%	5%
Aperture	5.9mm	12.6mm
Dielectric Withstanding Voltage(Hi-pot)	2500Vrms / 1 minute	4000Vrms / 1 minute
Vibration resistance	50 HZ, 98 m/s ²	
Weight	Approx. 12 g	Approx. 30 g

Dimensions (UNIT : mm)

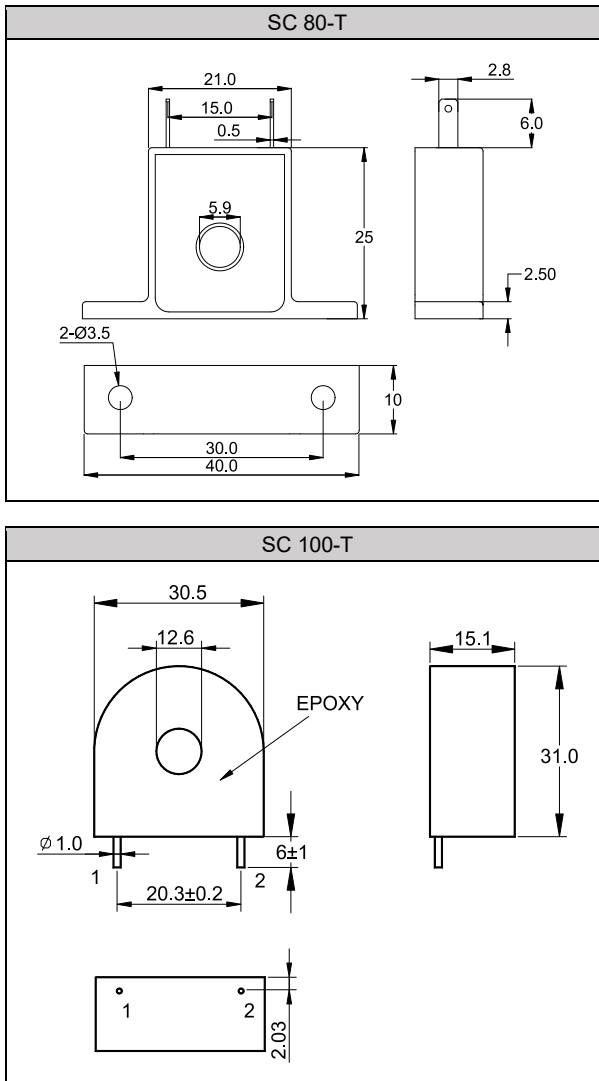

11.5 FUN Key

Description

The FUN key of FE700/800/900 is “programmable function key”. According to the setting value of parameter FKSL, it directly operates various events on the key.

With a two-second delay to prevent users from touching it inadvertently, it takes two seconds for the event to start.

FUN Key Mode table

LOOP	Parameter	Set value	Description
√	FKSL	OFF (0)	No action
		R_S (1)	Switch RUN/STOP mode <p>FUN — OFF — ON — OFF</p> <p>2 seconds</p> <p>R_S = RUN / STOP</p>
		A_M (2)	Switch AUTO/MMAN mode <p>FUN — OFF — ON — OFF</p> <p>2 seconds</p> <p>A_M = AUTO / MMAN</p>
		AT (3)	Autotuning ON/OFF mode <p>FUN — OFF — ON — OFF</p> <p>2 seconds</p> <p>AT = ON / OFF</p>
		LOOP (4)	Switch LOP1/ LOP2 <p>FUN — OFF — ON — OFF</p> <p>2 seconds</p> <p>LOOP = LOOP1 / LOOP2</p> <p>※ FKSL of LOOP1/LOOP2 should be set as LOOP</p>

Example

1. Use FUN key to switch loop1 manual/auto mode

Parameter Setting

LOOP	Level	Parameter	Set value	Description
1	4	SETB.3	1	Display loop1 FKSL
1	4	FKSL	A_M	Switch to manual/auto mode

2. Use FUN key to switch loop2 manual/auto mode

Parameter Setting

LOOP	Level	Parameter	Set value	Description
2	4	SETB.3	1	Display loop2 FKSL
2	4	FKSL	A_M	Switch to manual/auto mode

3. Use FUN key to switch loop1 run/stop mode

Parameter Setting

LOOP	Level	Parameter	Set value	Description
1	4	SETB.3	1	Display loop1 FKSL
1	4	FKSL	R_S	Switch to RUN/STOP mode

4. Use FUN key to switch loop2 activate/stop mode

Parameter Setting

LOOP	Level	Parameter	Set value	Description
2	4	SETB.3	1	Display loop2 FKSL
2	4	FKSL	R_S	Switch to RUN/STOP mode

5. Use FUN key to switch loop1/loop2

Parameter Setting

LOOP	Level	Parameter	Set value	Description
1	4	SETB.3	1	Display loop1 FKSL
1	4	FKSL	LOOP	Switch loop1 / loop2
2	4	SETB.3	1	Display loop2 FKSL
2	4	FKSL	LOOP	Switch loop1 / loop2

Notes

1. If the controller has DI function, please avoid setting the parameters D1SL/D2SL and FKSL to the same function mode to avoid confusion
2. FUN key factory default is A_M, switch manual/auto mode

11.6 Digital Input

Description

The FE controller provides two-point digital inputs that can be used to switch SV values through external switches or perform various events.

Function Diagram

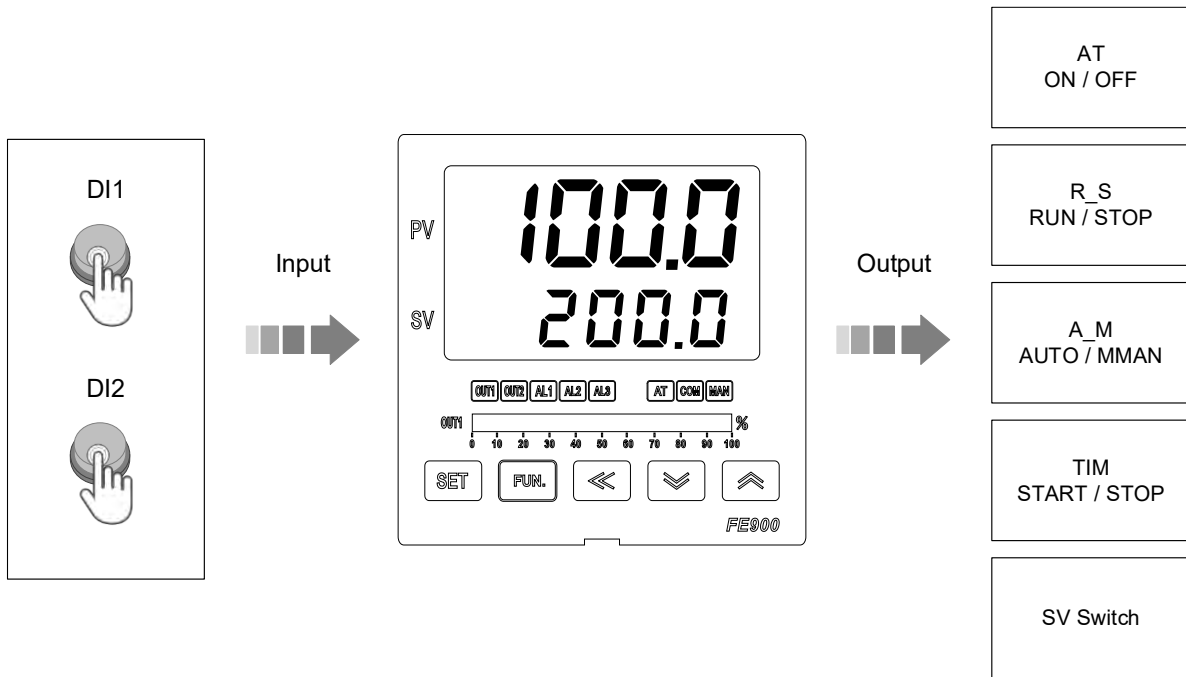

The related parameters of Digital Input are as below:

Parameter	Symbol	Content	Range		Default	Level	Hide/Display
			MAX	MIN			
D1SL		LOOP1 digital input function selection 0 : OFF (disable digital input function) 1 : SWSV (switch 4 sets of SV) 2 : R_S (switch RUN/STOP) 3 : A_M (switch Auto/Manual) 4 : AT (ON/OFF auto-tuning) 5 : RESV (ON/OFF remote SV) 6 : AOEN (ON/OFF retransmission) 7 : TIM (ON/OFF timer) 8 : CNT(counter) 9 : PROG (run/reset program)	PROG	OFF	OFF	Level 5	SETD.3
D2SL		LOOP2 digital input function selection 0 : OFF (disable digital input function) 1 : SWSV (switch 4 sets of SV) 2 : R_S (switch RUN/STOP) 3 : A_M (switch Auto/Manual) 4 : AT (ON/OFF auto-tuning) 5 : RESV (ON/OFF remote SV) 6 : AOEN (ON/OFF retransmission) 7 : TIM (ON/OFF timer) 8 : CNT(counter)	CNT	OFF	OFF	Level 5	SETD.3
SV1		First set value (only available in DI function)	USPL	LSPL	0	Level 1	SET2.1
SV2		Second set value (only available in DI function)	USPL	LSPL	0	Level 1	SET2.1
SV3		Third set value (only available in DI function)	USPL	LSPL	0	Level 1	SET2.2
SV4		Fourth set value (only available in DI function)	USPL	LSPL	0	Level 1	SET2.2

DI Mode table

Mode	Function Description	
OFF	D1SL=OFF	D2SL=OFF
	Disable Loop1 digital input function	Disable Loop2 digital input function
SWSV	D1SL= SWSV	D2SL= SWSV
	SV=SV1~SV4 Please refer to SV Switch table ※ If D1SL is set to SWSV, please set D2SL to OFF ※ If D2SL is set to SWSV, please set D1SL to OFF	
R_S	D1SL= R_S	D2SL= R_S
	Switch loop1 RUN/STOP ON 	Switch loop2 RUN/STOP ON
A_M	D1SL= A_M	D2SL= A_M
	Switch loop1 AUTO/MMAN ON 	Switch loop2 AUTO/MMAN ON
AT	D1SL= AT	D2SL= AT
	Switch loop1 autotuning ON/OFF ON 	Switch loop2 autotuning ON/OFF ON
RESV	D1SL= RESV	
	Switch loop1 SV to Local SV or Remote SV ON ※ D2SL should be set as OFF or other modes	
AOEN	D1SL= AOEN	D2SL= AOEN
	Switch Retransmission ON/OFF ON ※ If D2SL is set to AOEN, please set D1SL to OFF or other modes	Switch Retransmission ON/OFF ON ※ If D1SL is set to AOEN, please set D2SL to OFF or other modes
TIM	D1SL= TIM	D2SL= TIM
	Switch loop1 timer ON/OFF ON 	Switch loop2 timer ON/OFF ON

Mode	Function Description	
CNT	D1SL= CNT	D2SL= OFF
PROG	D1SL= PROG	
	Program execute	Program stop

SV Switch table

Mode	DI2	DI1	Function Description
SWSV	0	0	SV=SV1
			DI1 _____ OFF _____ DI2 _____ OFF _____
	0	1	SV=SV2
			DI1 _____ OFF _____ ON _____ DI2 _____ OFF _____
	1	0	SV=SV3
			DI1 _____ OFF _____ ON _____ DI2 _____ OFF _____ ON _____
	1	1	SV=SV4
			DI1 _____ OFF _____ ON _____ DI2 _____ OFF _____ ON _____

Example

- Use two sets of DI to switch 4 sets of SV
 Assuming Local SV=0, set SV1=100, SV2=200, SV3=150, SV4=250
 After the power is turned on, DI1=OFF, DI2=OFF, Local SV=100(SV1)
 When DI1=ON, DI2=OFF, local SV=200(SV2)
 When DI1=OFF, DI2=ON, local SV=150(SV3)
 When DI1=ON, DI2=ON, local SV=250(SV4)

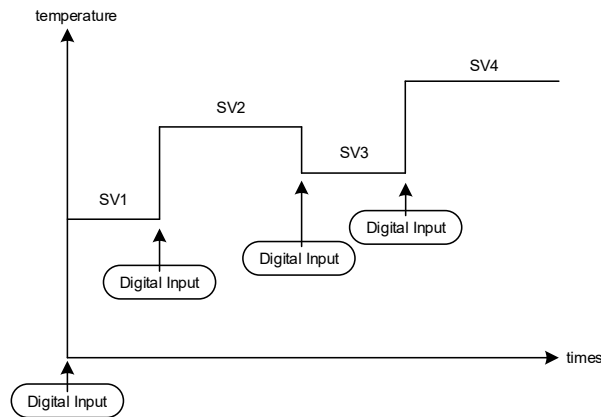

Parameter Setting

LOOP	Level	Parameter	Set value	Description
1	4	SET2.1	1	Display parameter SV1, SV2
1	4	SET2.2	1	Display parameter SV3, SV4
1	4	SETD.3	1	Display parameter D1SL, D2SL
---	5	D1SL	SWSV	Switch LOOP1 SV1~SV4
---	5	D2SL	OFF	---

- Switch DI1 of loop1 with DI1 = RUN/STOP
 Set D1SL = R_S, the controller will be in RUN mode after turning on DI1(ON) the controller will be in STOP mode after turning off DI1(OFF)

Parameter Setting

LOOP	Level	Parameter	Set value	Description
---	5	D1SL	R_S	DI1=ON R_S= RUN DI1=OFF R_S= STOP

- Switch DI2 of loop2 with DI2 = RUN/STOP
 Set D2SL = R_S, the controller will be in RUN mode after turning on DI2(ON) the controller will be in STOP mode after turning off DI2(OFF)

Parameter Setting

LOOP	Level	Parameter	Set value	Description
---	5	D2SL	R_S	DI2=ON R_S= RUN DI2=OFF R_S= STOP

- Start/stop loop 1 timer with DI1
 Set D1SL = TIM, TIM = 05.00 (5 minutes) the controller will start timing when DI1 is connected, and alarm 1 moves when the timer value reaches 5 minutes.

After disconnection of DI1, alarm 1 is released and the timer value is cleared

Parameter Setting

LOOP	Level	Parameter	Set value	Description
1	4	SET2.3	1	Display parameter TIM
1	1	TIM	05.00	Timer for 5 minutes
1	3	ALD1	TIM	When timer is up, alarm activates
---	5	D1SL	TIM	DI1 activates/ stop timer

- Use DI as a counter to count the external contact or pulse signal. When the count reaches 100, the alarm 1 activates.
 Set D1SL=CNT, CNT=100, the controller will start the counting function when DI1 is connected, the external contact or pulse signal is connected to DI2, when the count value reaches 100 times

Alarm 1 activates, alarm 1 is released after DI1 is disconnected, count value is cleared

Parameter Setting

LOOP	Level	Parameter	Set value	Description
1	4	SET2.4	1	Display parameter CNT
1	1	CNT	100	Target counter value of 100
1	3	ALD1	CNT	Alarm activated, once counter value is reached
---	5	D1SL	CNT	DI1 Activate counter/ DI2 used for counter value
---	5	D2SL	OFF	As D1SL=CNT, D2SL is forced to be OFF

11.7 Dehumidification Function

Description

The FE controller provides dehumidification to protect the heater. When the power is turned on, the heater is dehumidified with low power. When the dehumidification is completed, the normal power is output to the heater.

Function Diagram

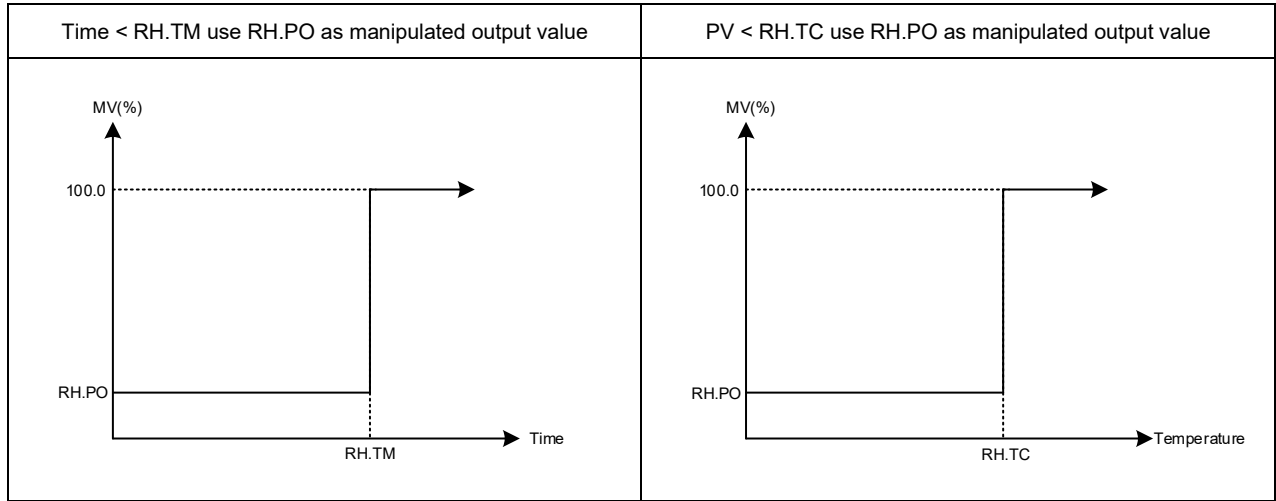

The related parameters of Dehumidification Function are as below:

Parameter	Symbol	Content	Range		Default	Level	Hide/Display
			MAX	MIN			
RH.TC	<i>RH.TC</i>	Dehumidification temperature If PV less than RH.TC manipulated value = RH.PO	200.0	0.0	125.0	Level 4	SETC.3
RH.PO	<i>RH.PO</i>	Dehumidification manipulated value 0 : OFF disable dehumidification function Other values : 0.1~100.0 manipulated value	100.0	OFF	OFF	Level 4	SETC.3
RH.TM	<i>RH.TM</i>	Dehumidification time time format : min.sec	COTI	00.00	15.00	Level 4	SETC.3

Example description

After the controller is turned on, when the PV does not reach 50°C, manipulated value fixed in 20%. When the time exceeds 15 minutes or the PV is greater than 50°C, the controller will produce output of normal PID gain.

Parameter Setting

LOOP	Level	Parameter	Set value	Description
1	4	SETC.3	1	Display parameter RH.TC, RH.PO, RH.TM
1	1	SV	100.0	Target temperature
1	4	RH.TC	50.0	Execute de-humidifying function when PV is lower than this temperature
1	4	RH.PO	20.0	When executing dehumidification function the manipulated value fixed in 20%
1	4	RH.TM	15.00	Max dehumidification function time

11.8 24-Hour Timer

Description

The FE controller provides a 24-hour timer to start/stop when a timer value arrives, or to switch SV

Function Diagram

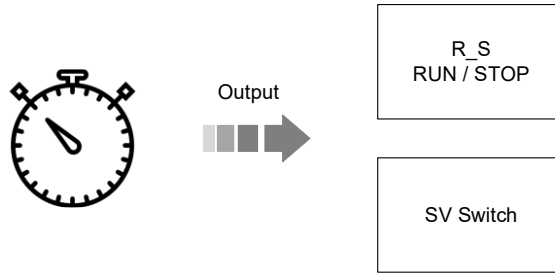

The related parameters of 24-Hour Timer are as below:

Parameter	Symbol	Content	Range		Default	Level	Hide/Display
			MAX	MIN			
CUTM		24 hour timer Current time	23.59	00.00	0	Level 1	SET3.1
ONTM		24 hour timer, ON time PV address use for display current time, SV address use for setting ON time	23.59	00.00	0	Level 1	SET3.1
OFTM		24 hour timer, OFF time PV address use for display current time, SV address use for setting OFF time	23.59	00.00	0	Level 1	SET3.1
TMSL		24 hour timer, mode selection 0 : OFF (24 hour timer function disable) 1 : SWSV (switch SV) 2 : R_S (switch RUN/STOP) 3 : R_SO (switch to run)	R_SO	OFF	OFF	Level 4	SETC.1

Flow Setting

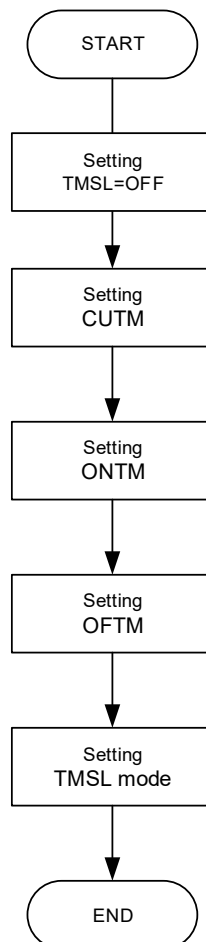

Example

1. The parameter R_S switches to the RUN at 8:30 a.m. and activate the alarm1 at the same time, the parameter switches to STOP at 17:30 p.m.

Parameter Setting

LOOP	Level	Parameter	Set value	Description
1	4	SET3.1	1	Display parameter CUTM ONTM OFTM
1	4	SETC.1	1	Display parameter TMSL
1	1	CUTM	---	Setting this parameter according to Greenwich Mean Time(GMT)
1	1	ONTM	08.30	Switch to RUN status at 8:30 a.m.
1	1	OFTM	17.30	Switch to STOP status at 17:30 p.m.
1	3	ALD1	CUTM	Switch to RUN status and activate alarm at the same time
1	4	TMSL	R S	Switch to RUN/STOP

2. Switch the parameter R_S to RUN at 8:30 a.m. and activate the alarm1

Parameter Setting

LOOP	Level	Parameter	Set value	Description
1	4	SET3.1	1	Display parameter CUTM ONTM OFTM
1	4	SETC.1	1	Display parameter TMSL
1	1	CUTM	---	Setting this parameter according to Greenwich Mean Time(GMT)
1	1	ONTM	08.30	Switch to RUN status at 8:30 a.m.
1	3	ALD1	CUTM	Switch to RUN status and activate alarm 1 at the same time
1	4	TMSL	R S	Switch to RUN/STOP

3. After controller boot completed the local SV=SV2, local SV switches to SV1 at 10:30 a.m., and local SV switches to SV2 at 1:30 p.m.

Parameter Setting

LOOP	Level	Parameter	Set value	Description
1	4	SET3.1	1	Display parameter CUTM ONTM OFTM
1	4	SETC.1	1	Display parameter TMSL
1	4	SET2.1	1	Display parameter SV1 SV2
1	1	CUTM	---	Setting this parameter according to Greenwich Mean Time(GMT)
1	1	ONTM	10.30	Switch SV=SV1 at 10:30 a.m.
1	1	OFTM	13.30	Switch SV=SV2 at 01:30 p.m.
1	4	TMSL	SWSV	Switch SV

11.9 Piece Linear Compensation

Description

When the analog input signal source is nonlinear, using piece linear compensation method to compensate this signal, make it linearity

The related parameters of piece linear compensation are as below:

Parameter	Symbol	Content	Range		Default	Level	Hide/Display
			MAX	MIN			
MLNB		Piece linear compensation segment select TRIP : leave setting loop 1~10 : segment select	10	TRIP	TRIP	Level 3	SETA.3
COMP		Piece linear compare value	USPL	LSPL	LSPL	Level 3	SETA.3
OFFS		Piece linear offset value	150.0	-150.0	0.0	Level 3	SETA.3
SETA.3		0 : MLNB, COMP, OFFS hide 1 : MLNB, COMP, OFFS display	1	0	0	Level 4	---
SETF.4		0 : Disable piece linear compensation 1 : Enable piece linear compensation	1	0	0	Level 5	SETF.4

Edit flow-chat

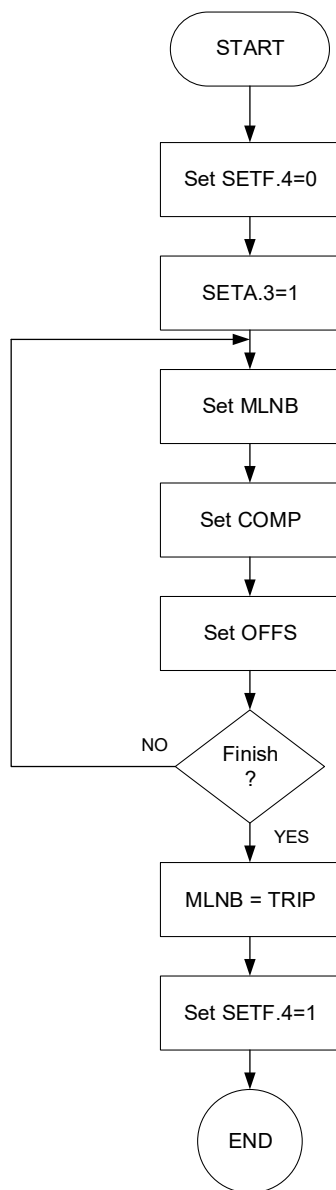

Set MLNB

Parameter	LED display	Description	Default	Level
MLNB		Piece linear compensation segment select TRIP : leave setting loop 1~10 : segment select	TRIP	Level 3

When MLNB≠TRIP the display loop in MLNB → COMP → OFFS

When MLNB=TRIP leave piece linear compensation parameter loop

Set COMP

Parameter	LED display	Description	Default	Level
COMP		Piece linear compensation compare value	LSPL	Level 3

When non-linear signal value within the set value of COMP, it needs to be compensated.

First COMP set value=LSPL

Last COMP set value=USPL

Set OFFS

Parameter	LED display	Description	Default	Level
OFFS		Piece linear compensation offset value	0.0	Level 3

When non-linear signal value within the set value of COMP, OFFS use for increase or decrease original non-linear signal

Before the function starts

Piece Linear Compensation

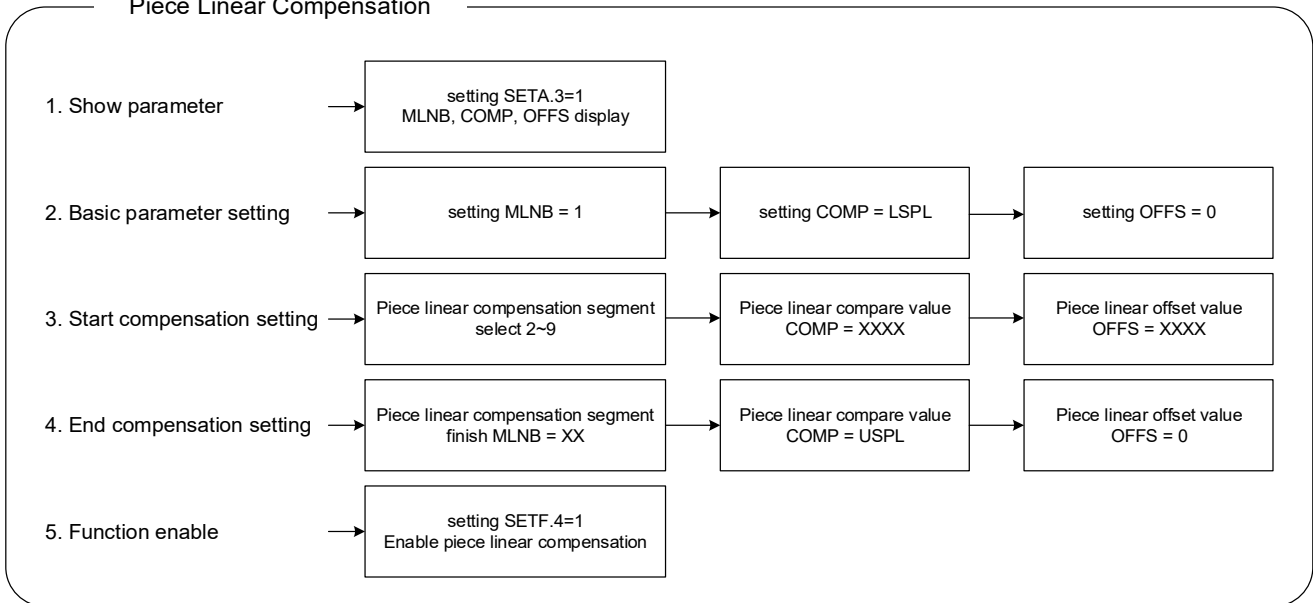

Example1:

Assume signal source is a nonlinear signal within 320 °C, and the controller is set to correct at three temperature points.

- (1) When the temperature is 95°C, it needs to be corrected by +5°C.
- (2) When the temperature is 185°C, it needs to be corrected by +15°C.
- (3) When the temperature is 320°C, it needs to be corrected by +30°C.

- Step 1: Set SETA.3=1 and SETF.4=0
- Step 2: Set MLNB = 1, COMP = LSPL, OFFS = 0
- Step 3: set MLNB = 2, COMP = 95, OFFS = 5
- Step 4: Set MLNB = 3, COMP = 185, OFFS = 15
- Step 5: Set MLNB = 4, COMP = 320, OFFS = 30
- Step 6: Set MLNB = 5, COMP = USPL, OFFS = 0
- Step 7: Set MLNB = TRIP and SETF.4=1

Example2:

Input signal 4~20mA, range 0~5000, the input signal is nonlinear (as shown in the figure below), use 10 points piece linear compensation.

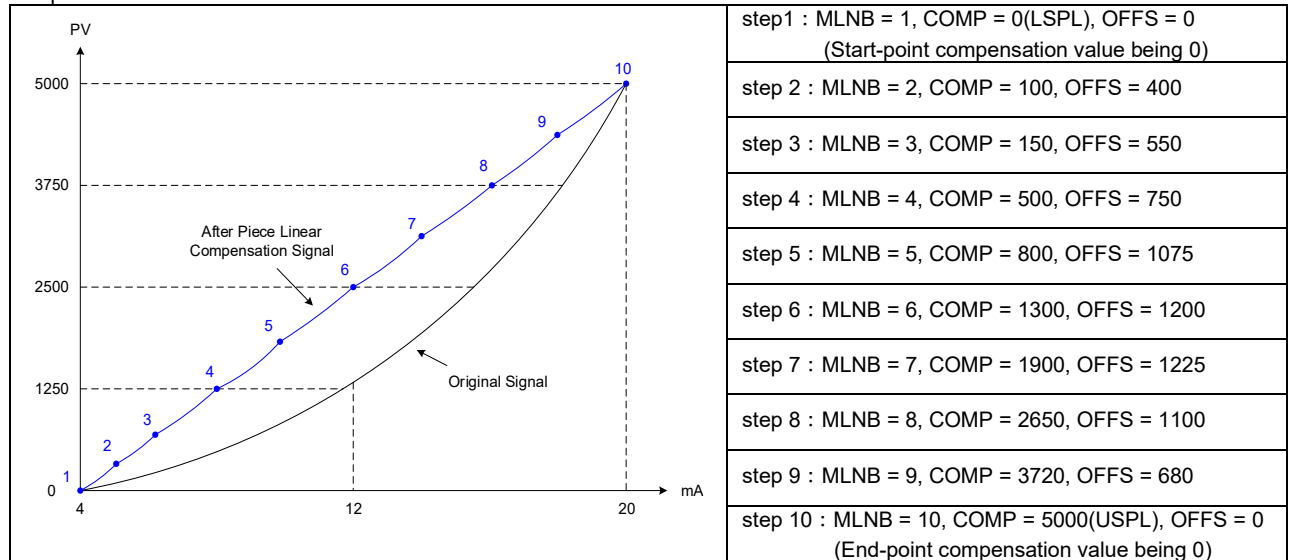

11.10 RAMP & SOAK

Description

The FE series controller provides a single ramp and soak function, after booting completed, the SV starts to increase according to the set value of RAMP. When the soak condition is met the SOAK function will be executed according to the set value of SOAK, and driving the output and alarm to ON or OFF after the SOAK time is executed finish.

The related parameters of ramp and soak function are as below:

Parameter	Symbol	Content	Range		Default	Level	Hide/Display
			MAX	MIN			
RAMP	<i>RAMP</i>	The rate of change during SV ramp operation format : °C / minute	99.99	-19.99	0.00	Level 1	SV.TY=RAMP & SETE.4
SOAK	<i>SOAK</i>	Soak time Time format : min.sec	COTI	0.00	0.10	Level 1	ALDX=MSOK ALDX=SOAK ALDX=FSOK

※ X=1 / 2 / 3

Parameter	Set value	Symbol	Content
ALDX	MSOK	<i>MSOK</i>	Boot completed, the alarm is ON. When PV ≥ target SV start the soak timer, alarm and control function are turned OFF in soak time finish
	SOAK	<i>SOAK</i>	Boot completed, the alarm is ON (1) RAMP SV reach target SV (2) PV ≥ target SV When both above conditions are true start the soak timer, alarm and control function are turned OFF in soak time finish (in this function ramp function is necessary)
	FSOK	<i>FSOK</i>	Boot completed, the alarm is OFF. when PV ≥ target SV start the soak timer, alarm is turned ON and the control function keep ON in soak time finish

※ X=1 / 2 / 3

Example (1) RAMP+SOAK

Boot completed, the alarm is ON, target SV=100.0, SV rising 5.00°C per minute

(1) RAMP SV reach 100.0

(2) PV ≥ 100.0

When both above conditions are true start the soak timer, alarm and parameter R_S are turned OFF in soak time finish

Parameter setting

LOOP	Level	Parameter	Set value	Description
1	1	SV	100.0	target SV
1	1	R_S	RUN	enable control and alarm function
1	1	RAMP	5.00	rising 5.00°C per minute
1	1	SOAK	10.00	soak time=10 minutes
1	3	ALD1	SOAK	alarm1 as soak alarm
1	4	SV.TY	RAMP	SV source RAMP function
1	4	SETE.4	1	display RAMP

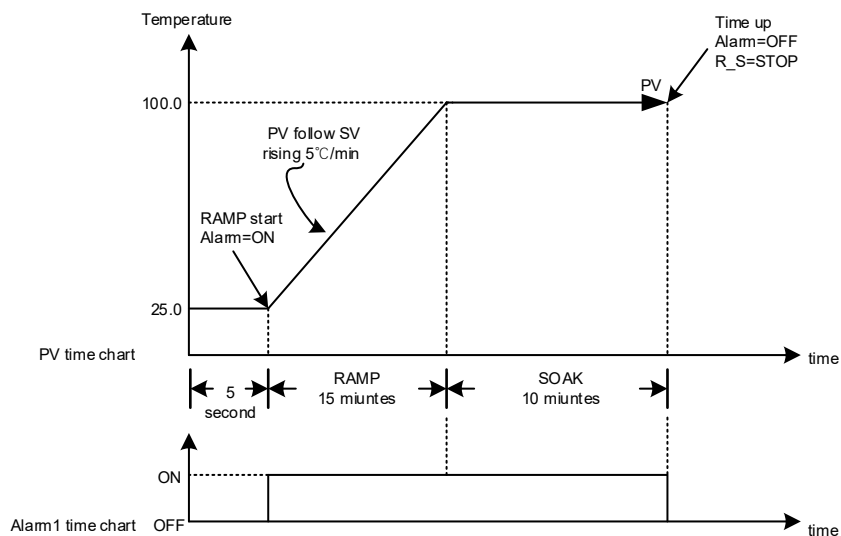

Change SV to re-execute RAMP/SOAK function

1. Parameter R_S display in LEVEL_1

After change SV, set parameter R_S=RUN, controller will re-execute RAMP/SOAK function

2. Parameter R_S hide in LEVEL_1

After change SV, controller will re-execute RAMP/SOAK function automatically

Example (2) RAMP+MSOK

Boot completed, the alarm is ON, target SV=100.0, SV rising 5.00°C per minute

When PV ≥ 100.0 start the soak timer, alarm and parameter R_S are turned OFF in soak time finish.

Parameter setting

LOOP	Level	Parameter	Set value	Description
1	1	SV	100.0	target SV
1	1	R_S	RUN	enable control and alarm function
1	1	RAMP	5.00	rising 5.00°C per minute
1	1	SOAK	10.00	soak time=10 minutes
1	3	ALD1	MSOK	alarm1 as soak alarm
1	4	SV.TY	RAMP	SV source RAMP function
1	4	SETE.4	1	display RAMP

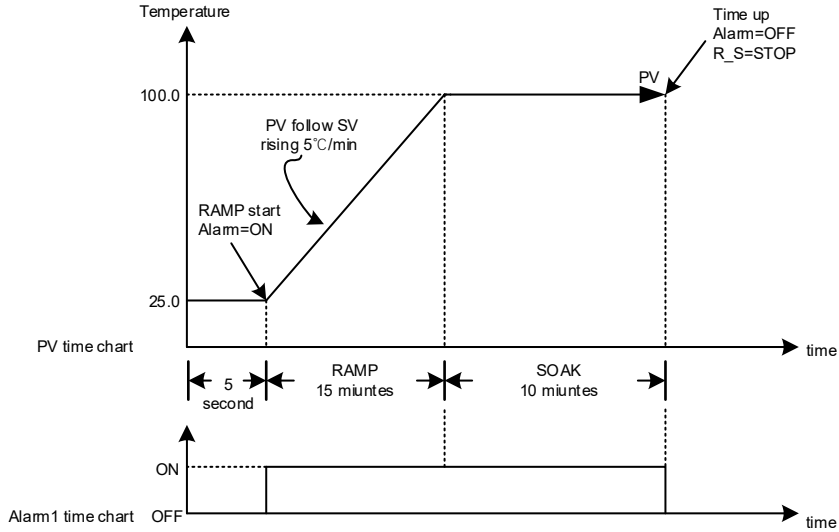

Change SV to re-execute RAMP/SOAK function

1. Parameter R_S display in LEVEL_1

After change SV, set parameter R_S=RUN, controller will re-execute RAMP/SOAK function

2. Parameter R_S hide in LEVEL_1

After change SV, controller will re-execute RAMP/SOAK function automatically

Example (3) RAMP+FSOK

Boot completed, the alarm is OFF, target SV=100.0, SV rising 5.00°C per minute

When PV ≥ 100.0 start the soak timer, alarm is turned ON and parameter R_S keep RUN state in soak time finish

Parameter setting

LOOP	Level	Parameter	Set value	Description
1	1	SV	100.0	target SV
1	1	R_S	RUN	enable control and alarm function
1	1	RAMP	5.00	rising 5.00°C per minute
1	1	SOAK	10.00	soak time=10 minutes
1	3	ALD1	FSOK	alarm1 as soak alarm
1	4	SV.TY	RAMP	SV source RAMP function
1	4	SETE.4	1	display RAMP

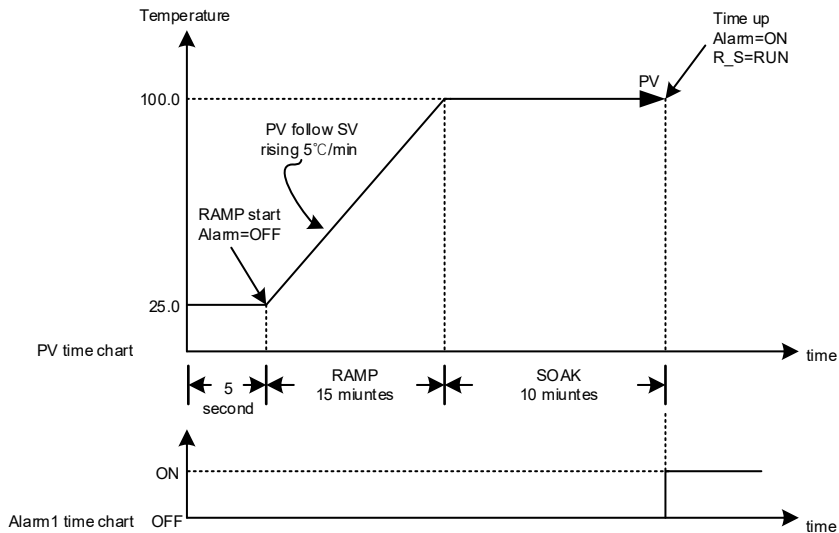

Example (4) use only MSOK

Boot completed, the alarm is ON, target SV=100.0, control PV to 100.0 directly

When PV ≥ 100.0 start the soak timer, alarm and parameter R_S are turned OFF in soak time finish

Parameter setting

LOOP	Level	Parameter	Set value	Description
1	1	SV	100.0	target SV
1	1	R_S	RUN	enable control and alarm function
1	1	SOAK	10.00	soak time=10 minutes
1	3	ALD1	MSOK	alarm1 as soak alarm
1	4	SV.TY	FIX	SV change by keypad

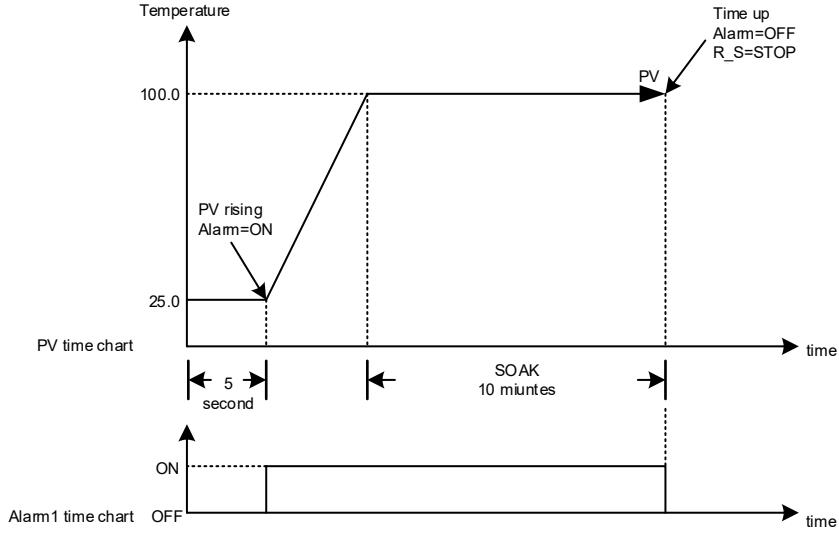

Change SV to re-execute RAMP/SOAK function

1. Parameter R_S display in LEVEL_1

After change SV, set parameter R_S=RUN, controller will re-execute RAMP/SOAK function

2. Parameter R_S hide in LEVEL_1

After change SV, controller will re-execute RAMP/SOAK function automatically

Example (5) use only FSOK

Boot completed, the alarm is OFF, target SV=100.0, control PV to 100.0 directly

When PV ≥ 100.0 start the soak timer, alarm is turned ON and parameter R_S keep RUN state in soak time finish

Parameter setting

LOOP	Level	Parameter	Set value	Description
1	1	SV	100.0	target SV
1	1	R_S	RUN	enable control and alarm function
1	1	SOAK	10.00	soak time=10 minutes
1	3	ALD1	FSOK	alarm1 as soak alarm
1	4	SV.TY	FIX	SV change by keypad

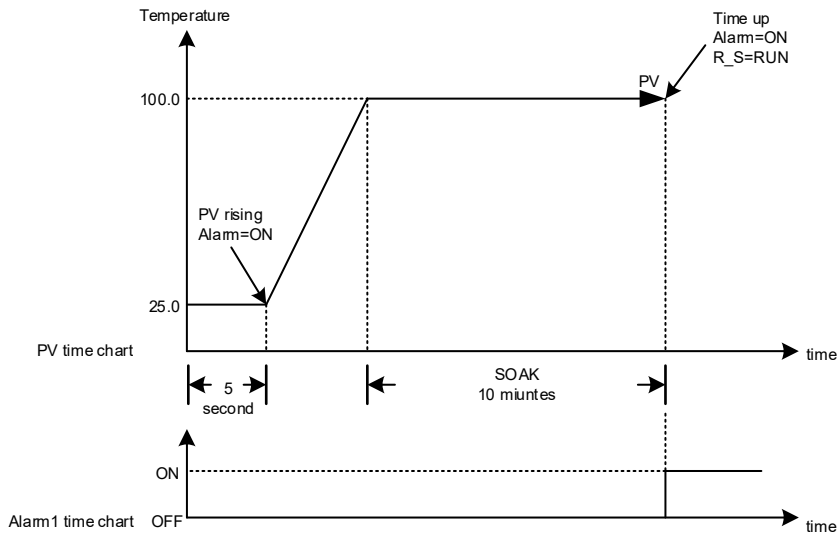

11.11 Password

Description

The FE series controller provides a password function to inhibit operator enter Level 3~5.

The related parameters of password function are as below:

Parameter	Symbol	Content	Range		Default	Level	Hide/Display
			MAX	MIN			
PW		Password input value	9999	0	0	Level 1	SET2.4 (loop2)
MPW	---	<p>Verification code setting value This parameter can only be modified by communication address : 1022</p> <p>0 : No password protection ,user can enter Level 3~5 according to the value of LOCK</p> <p>others : When password input value and verification code are the same, user can enter Level 3~5 according to the value of LOCK. otherwise, user cannot enter Level 3~5.</p>	9999	0	0	---	---

example

Set verification code=1234 via communication

1. input 1234 in the parameter PW, allow enter Level_1~3
2. input 5678 in the parameter PW, inhibit enter Level_1~3

There is a limit on the number of input passwords, after more than 3 times, it will be locked and cannot be entered.

If user want to unlock please contact factory or distributor.

Parameter setting

LOOP	Level	Parameter	Set value	Description
2	1	PW	1234	password input value
---	---	MPW	1234	verification code, modify via communication

Notes

1. The value of the verification code can only be modified through communication
2. Password input value(PW) in LOOP2, to password input, please set parameter LOOP to LOP2 first
3. There is a limit on the number of password input ,please remember the value of verification code

11.12 Proportional Control

Description

Proportional control is one of the simplest ways to control method, controller manipulated value proportional to input error signal, this chapter explains how to set related parameters.

Function Diagram

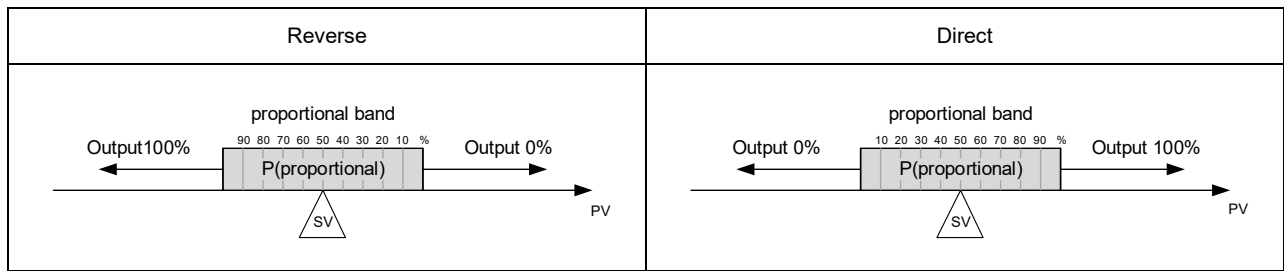

The related parameters of proportional control are as below:

Parameter	Symbol	Content	Range		Default	Level	Hide/Display
			MAX	MIN			
SV	---	Set value	USPL	LSPL	---	Level 1	---
P1		Main output proportional band 0.0 : ON/OFF control Other values : proportional band setting value	200.0	0.0	3.0	Level 2	---
OUTM		Control action selection 0 : HEAT reverse action 1 : COOL direct action	COOL	HEAT	HEAT	Level 3	SET9.4

Setting step

1. Select control action
2. Determine the proportional band
3. Set SV, $SV = (\text{proportional band maximum} + \text{proportional band minimum}) / 2$
4. Full range = (Range maximum – range minimum)
5. Calculate $P = ((\text{proportional band maximum} - \text{proportional band minimum}) / \text{Full range}) \times 100$

Example 1 :

INPT = K1(-50.0~600.0) when PV in the range of 90.0 ~ 100.0 output proportional(decrease) SV = ? P = ?

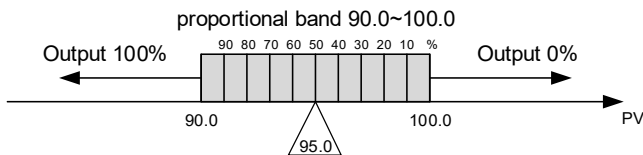

1. OUD = HEAT(Reverse)
2. Proportional band → 90.0~100.0
3. $SV = (\text{proportional band maximum} + \text{proportional band minimum}) / 2$
→ $(100.0 + 90.0) / 2 = 95.0$
4. Full range = (Range maximum – range minimum)
→ $600.0 - (-50.0) = 650.0$
5. $P = ((\text{proportional band maximum} - \text{proportional band minimum}) / \text{Full range}) \times 100$
→ $((100.0 - 90.0) / 650.0) \times 100 = 1.5384(\text{approx } 1.5)$

Example 2 :

INPT = AN4(0.0~100.0) when PV in the range of 0.0 ~ 100.0 output proportional(increase) SV = ? P = ?

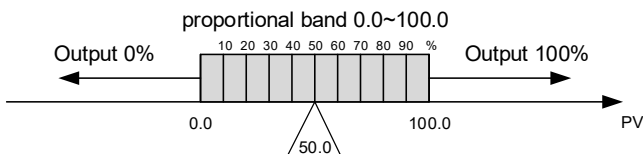

1. OUD = COOL(Direct)
2. Proportional band → 0.0~100.0
3. $SV = (\text{proportional band maximum} + \text{proportional band minimum}) / 2$
→ $(100.0 + 0.0) / 2 = 50.0$
4. Full range = (Range maximum – range minimum)
→ $100.0 - 0.0 = 100.0$
5. $P = ((\text{proportional band maximum} - \text{proportional band minimum}) / \text{Full range}) \times 100$
→ $((100.0 - 0.0) / 100.0) \times 100 = 100.0$

Notes

1. When using proportional control I1 and D1 must be set to 0
2. Full range please check Chapter 4 "Input Range Table"
3. Only using proportional control will eventually have a steady state error

11.13 Master-Slave Communication

Description

Transmission master controller SV to slave controller SV, all slave controller SV can be consistent

Wiring

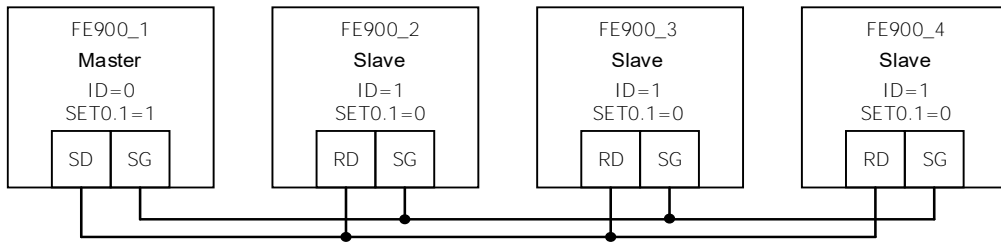

The related parameters of master-slave communication are as below:

Parameter	Symbol	Content	Range		Default	Level	Hide/Display
			MAX	MIN			
RATE	<i>9999</i>	Slave SV rate RATE SV = SV x (RATE/9999)	9999	0	9999	Level 1	SET2.1 & SET0.2
PRTO	<i>0000</i>	Protocol selection 0 : TAIE 1 : MRTU (Please refer to communication manual)	RTU	TAIE	TAIE	Level 3	SET5.4
FOMA	<i>0000</i>	Data format 0 : O_81 (parity bit=odd, stop bit=1) 1 : O_82 (parity bit=odd, stop bit=2) 2 : E_81 (parity bit=even, stop bit=1) 3 : E_82 (parity bit=even, stop bit=2) 4 : N_81 (parity bit=none, stop bit=1) 5 : N_82 (parity bit=none, stop bit=2)	N_82	O_81	O_81	Level 3	SET5.4
IDNO	<i>0000</i>	Controller station	254	0	1	Level 3	SET5.4
BAUD	<i>0000</i>	Baud rate 0 : 24(2400) 1 : 48(4800) 2 : 96(9600) 3 : 192(19200) 4 : 384(38400) 5 : 576(57600) 6 : 1152(115200) bps	1152	24	96	Level 3	SET5.4

Master controller setting step

1. IDNO= 0, PRTO= TAIE
2. FOMA= O_81, BAUD= 96
3. After completing the above steps, master controller start to transmit SV to slave controller SV

Slave controller setting step

1. IDNO= 1, PRTO= TAIE
2. FOMA= O_81, BAUD= 96
3. RATE= 9999
4. After completing the above steps, slave controller start to receive master controller SV

Notes

1. Afer adding master-slave communication, RS-485 communication not available
2. Master-slave communication only available in TAIE protocol(PRTO= TAIE)
3. Master controller does not use parameter RATE, to attenuate the SV received by slave controller just adjust parameter RATE
4. Master controller can connect up to 10 slave controllers, and the wiring between every controller should not exceed 1 meter.

11.14 Auto-tuning

Description

Auto-tuning

When AT is executed, the optimum PID constants for the SV at that time are set automatically. A method (called the limit cycle method) for forcibly changing the manipulated variable and finding the characteristics of the control object is employed.

The related parameters of Auto-tuning and Startup tuning function are as below:

Parameter	Symbol	Content	Range		Default	Level	Hide/Display
			MAX	MIN			
AT		Auto-tuning execute selection 0 : OFF (PID control) 1 : ON (execute auto-tuning)	ON	OFF	OFF	Level 1	SET3.3
AT.VL		Auto-tuning offset value execute auto-tuning in (SV-ATVL) point	100.0	-100.0	0.0	Level 2	SET6.2

Auto-tuning diagram

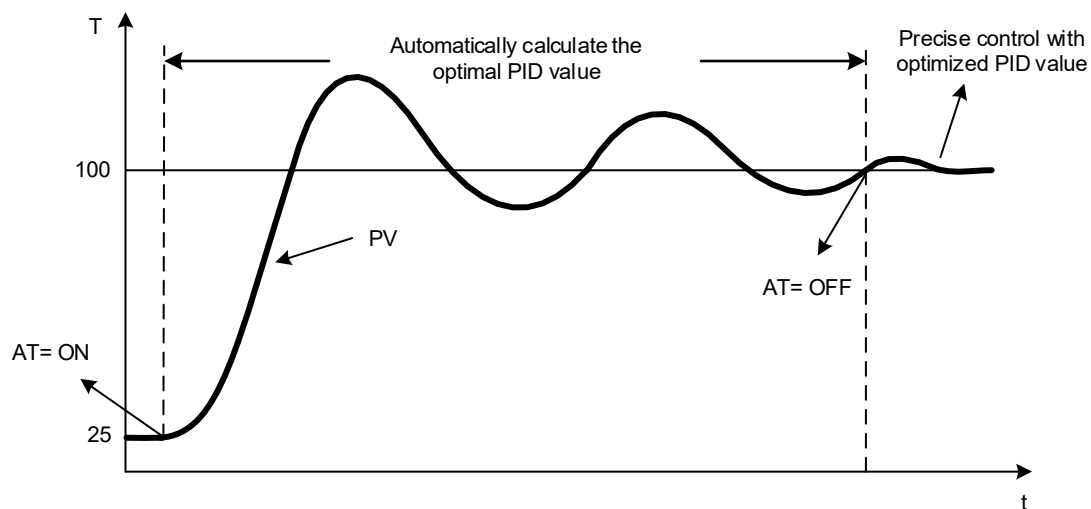

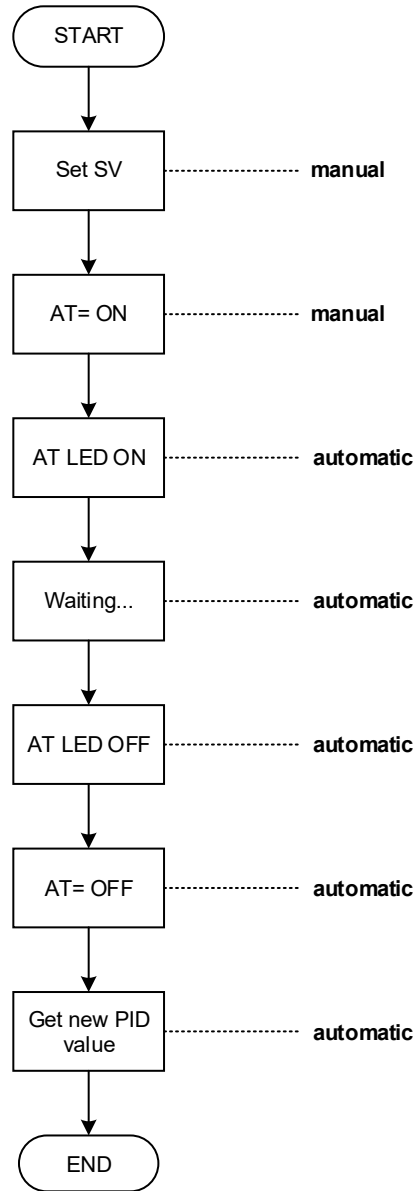

Notes

1. During the execution of auto-tuning, PV will change significantly, do not production during this period of time
2. During the execution of auto-tuning, please release the function of limiting the output percentage first(set OUTL=100.0)
3. If the alarm terminal link to output terminal, please release it before the execution of auto-tuning.
4. if execute auto-tuning over 2 hours, the controller will return to the control state and display the auto-tuning failure message (AUTF)
5. If the system components (e.g. heater, sensor...) are replaced, please execute the auto-tuning again
6. Auto-tuning can be used for heating or cooling equipment
7. Perform auto-tuning on the dual-output controller, the PID values on the heating side and cooling side will be updated at the same time
8. Can perform auto-tuning at any temperature

11.15 ON / OFF Control

Description

In ON/OFF control, the output is turned on or off depending on the measured value (PV) whether it is above or below the Set value (SV), user can set a hysteresis zone to prevent turned on and off too frequently for a small change of temperature.

Function Diagram (single output, heat mode)

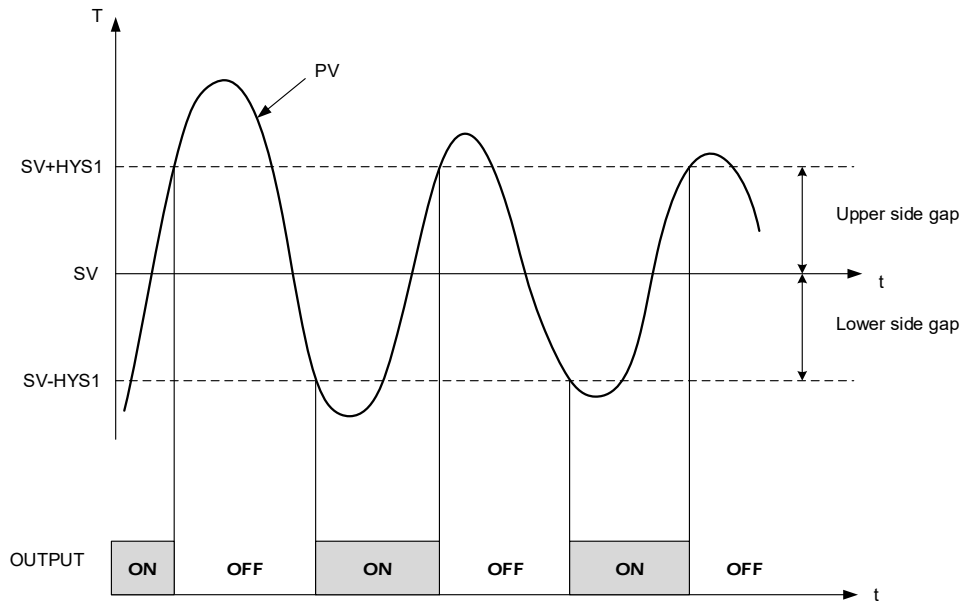

The related parameters of ON/OFF control are as below:

Parameter	Symbol	Content	Range		Default	Level	Hide/Display
			MAX	MIN			
P1	PP1	Main output proportional band 0.0 : ON/OFF control Other values : proportional band setting value	200.0	0.0	3.0	Level 2	---
HYS1	HYS1	Hysteresis for main output on/off control use (when P1 = 0.0 appear)	100.0	-100.0	1.0	Level 2	P1 = 0.0
P2	PP2	Sub output proportional band 0.0 : ON/OFF control Other values : proportional band setting value	200.0	0.0	3.0	Level 2	OUTY = 1
HYS2	HYS2	Hysteresis for sub output on/off control use (when P2 = 0.0 appear)	100.0	-100.0	1.0	Level 2	P2 = 0.0
MGAP	GGAP	Control gap (for main output)	1000	-1000	0	Level 2	OU.TY = DOUB
SGAP	GGAP	Control gap (for sub output)	1000	-1000	0	Level 2	OU.TY = DOUB
OUTM	OUTM	Control action selection 0 : HEAT reverse action 1 : COOL direct action	COOL	HEAT	HEAT	Level 3	SET9.4

Example(1)

single output, heat mode

Description	When $PV \leq 95.0^{\circ}\text{C}$ OUT1 : ON · When $PV \geq 105.0^{\circ}\text{C}$ OUT1 : OFF
Formula	$PV \geq (SV + HYS1) \rightarrow \text{OUT1 OFF}$ $PV \leq (SV - HYS1) \rightarrow \text{OUT1 ON}$
diagram	
Parameter setting	SV=100.0 P1=0.0 HYS1=5.0 OUTM =HEAT

Example(2)
single output, cool mode

Description	When $PV \geq 20.0^{\circ}\text{C}$ OUT1 : ON · When $PV \leq 10.0^{\circ}\text{C}$ OUT1 : OFF
Formula	$PV \geq (SV + HYS1) \rightarrow \text{OUT1 ON}$ $PV \leq (SV - HYS1) \rightarrow \text{OUT1 OFF}$
diagram	
Parameter setting	SV=15.0 P1=0.0 HYS1=5.0 OUTM =COOL

Example(3)
dual output(OUT1 : heat mode, OUT2 : cool mode)

Formula	heat side	$PV \geq (SV + MGAP) \rightarrow \text{OUT1 OFF}$ $PV < (SV + MGAP - HYS1) \rightarrow \text{OUT1 ON}$
	Cool side	$PV \leq (SV + SGAP) \rightarrow \text{OUT2 OFF}$ $PV > (SV + SGAP - HYS2) \rightarrow \text{OUT2 ON}$
diagram		

Example(4)
dual output(OUT1 : cool mode, OUT2 : heat mode)

Formula	Cool side	$PV \leq (SV + MGAP) \rightarrow \text{OUT1 OFF}$ $PV > (SV + MGAP + HYS1) \rightarrow \text{OUT1 ON}$
	heat side	$PV \geq (SV + SGAP) \rightarrow \text{OUT2 OFF}$ $PV < (SV + SGAP - HYS2) \rightarrow \text{OUT2 ON}$
diagram		

Notes

1. There is a large control error in ON/OFF control compared with PID control
2. Do not set the hysteresis parameter HYS1/HYS2 too small, so as to avoid frequent action of the relay and affect the life time
3. When performing ON/OFF control in dual output mode, both sets of outputs must be used for ON/OFF control, please do not adjust to one set of PID control and one set of ON/OFF control

11.16 Super SV

Description

When the SV is changed, the output increases, massive output may cause overshoot and damage the system. FE series controllers provide the Super SV function, which can effectively suppress the overshoot

The related parameters of Super SV are as below:

Parameter	Symbol	Content	Range		Default	Level	Hide/Display
			MAX	MIN			
SETA.4	<i>SEEP</i>	Super SV function, suppressing overshoot 0 : OFF 1 : ON	1XXX	0XXX	0XXX	Level 4	---

Example

Set the SV to 100.0°C, use the default PID value to control the industrial oven, and compare the control curves of Super SV function on or off

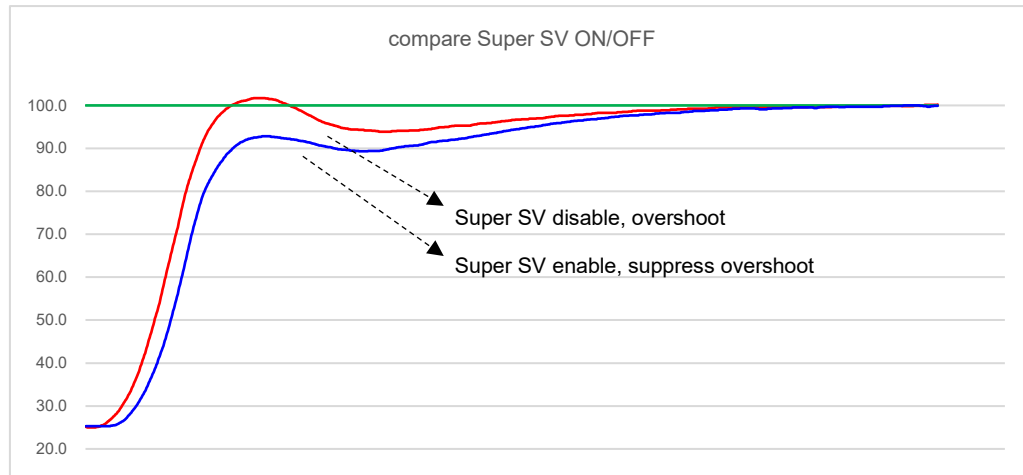

Notes

1. The time to reach the set value after enabling Super SV function may be longer than the time without Super SV function
2. I (Integral) value cannot be zero when using Super SV function
3. Super SV function is recommended for single output heating system

11.17 Input Math Function

Description

FE series controllers provide advance mathematical function in terms of input linear signals, such as inverse, square root, square etc. Users can directly connect differential pressure type flow transmitter to controller, or other transmitters that require special conversion.

The related parameters of Input math function are as below:

Parameter	Symbol	Content	Range		Default	Level	Hide/Display
			MAX	MIN			
HI.RA	<i>HI.RA</i>	Input scale high(for analog input)	9999	-1999	---	Level 3	SET7.2
LO.RA	<i>LO.RA</i>	Input scale low(for analog input)	9999	-1999	---	Level 3	SET7.2
MV.SF	<i>MV.SF</i>	Analog input special function selection 0 : NONE (special function OFF) 1 : SQUA (analog input square) 2 : ROOT (analog input square root) 3 : REVE (analog input reverse) 4 : SQ.RE (analog input square reverse) 5 : RO.RE (analog input square root reverse)	RO.RE	NONE	NONE	Level 3	INPT=AN1~AN4

Notes

1. The parameter MV.SF is only available in when the input signal is a linear signal (INPT=AN1~AN4)
2. When using the SQUA/ROOT/SQ.RE/RO.RE function, you must ensure that the range is a positive range

Example(1)

Input signal 4~20mA aim range 0~1000, the value and graphical representation of MV.SF functions

input signal 4~20mA	NONE	REVE (reverse)	SQUA (square)	SQ.RE (square+ reverse)	ROOT (square root)	RO.RE (square root+ reverse)
4.00	0	1000	0.0	1000.0	0.00	1000.00
4.32	20	980	0.4	999.6	141.42	858.58
4.64	40	960	1.6	998.4	200.00	800.00
4.96	60	940	3.6	996.4	244.95	755.05
5.28	80	920	6.4	993.6	282.84	717.16
5.60	100	900	10.0	990.0	316.23	683.77
5.92	120	880	14.4	985.6	346.41	653.59
6.24	140	860	19.6	980.4	374.17	625.83
6.56	160	840	25.6	974.4	400.00	600.00
6.88	180	820	32.4	967.6	424.26	575.74
7.20	200	800	40.0	960.0	447.21	552.79
7.52	220	780	48.4	951.6	469.04	530.96
7.84	240	760	57.6	942.4	489.90	510.10
8.16	260	740	67.6	932.4	509.90	490.10
8.48	280	720	78.4	921.6	529.15	470.85
8.80	300	700	90.0	910.0	547.72	452.28
9.12	320	680	102.4	897.6	565.69	434.31
9.44	340	660	115.6	884.4	583.10	416.90
9.76	360	640	129.6	870.4	600.00	400.00
10.08	380	620	144.4	855.6	616.44	383.56
10.40	400	600	160.0	840.0	632.46	367.54
10.72	420	580	176.4	823.6	648.07	351.93
11.04	440	560	193.6	806.4	663.32	336.68
11.36	460	540	211.6	788.4	678.23	321.77
11.68	480	520	230.4	769.6	692.82	307.18
12.00	500	500	250.0	750.0	707.11	292.89
12.32	520	480	270.4	729.6	721.11	278.89
12.64	540	460	291.6	708.4	734.85	265.15
12.96	560	440	313.6	686.4	748.33	251.67
13.28	580	420	336.4	663.6	761.58	238.42
13.60	600	400	360.0	640.0	774.60	225.40
13.92	620	380	384.4	615.6	787.40	212.60
14.24	640	360	409.6	590.4	800.00	200.00
14.56	660	340	435.6	564.4	812.40	187.60
14.88	680	320	462.4	537.6	824.62	175.38
15.20	700	300	490.0	510.0	836.66	163.34
15.52	720	280	518.4	481.6	848.53	151.47
15.84	740	260	547.6	452.4	860.23	139.77
16.16	760	240	577.6	422.4	871.78	128.22
16.48	780	220	608.4	391.6	883.18	116.82
16.80	800	200	640.0	360.0	894.43	105.57
17.12	820	180	672.4	327.6	905.54	94.46
17.44	840	160	705.6	294.4	916.52	83.48
17.76	860	140	739.6	260.4	927.36	72.64
18.08	880	120	774.4	225.6	938.08	61.92
18.40	900	100	810.0	190.0	948.68	51.32
18.72	920	80	846.4	153.6	959.17	40.83
19.04	940	60	883.6	116.4	969.54	30.46
19.36	960	40	921.6	78.4	979.80	20.20
19.68	980	20	960.4	39.6	989.95	10.05
20.00	1000	0	1000.0	0.0	1000.00	0.00

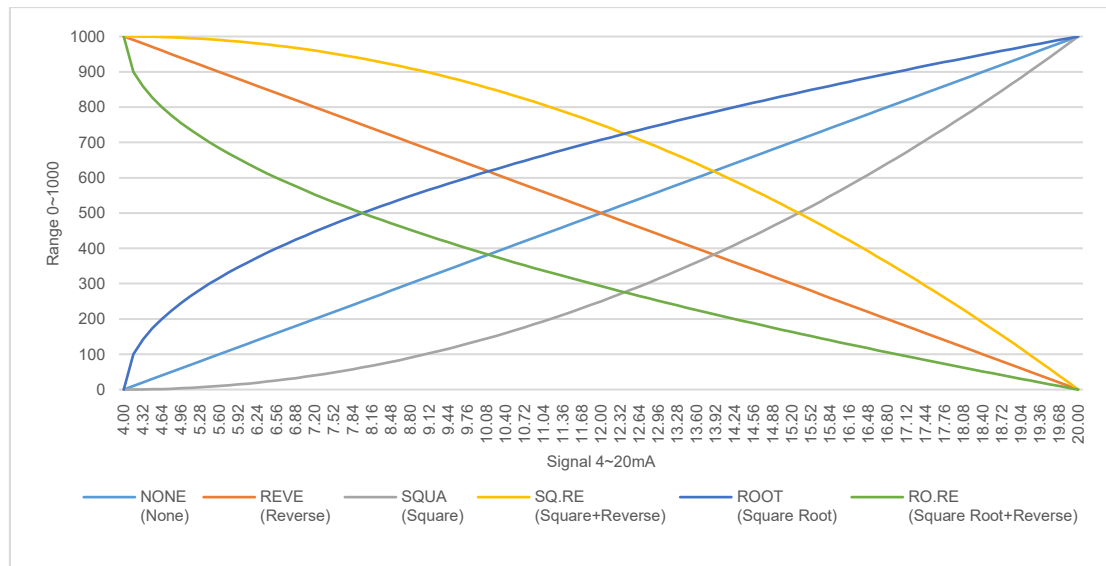

Example(2)

Input signal 0~10V aim range 0~1000, the value and graphical representation of MV.SF functions

input signal 0~10V	NONE	REVE (reverse)	SQUA (square)	SQ.RE (square+ reverse)	ROOT (square root)	RO.RE (square root+ reverse)
0.0	0	1000	0.0	1000.0	0.00	1000.00
0.2	20	980	0.4	999.6	141.42	858.58
0.4	40	960	1.6	998.4	200.00	800.00
0.6	60	940	3.6	996.4	244.95	755.05
0.8	80	920	6.4	993.6	282.84	717.16
1.0	100	900	10.0	990.0	316.23	683.77
1.2	120	880	14.4	985.6	346.41	653.59
1.4	140	860	19.6	980.4	374.17	625.83
1.6	160	840	25.6	974.4	400.00	600.00
1.8	180	820	32.4	967.6	424.26	575.74
2.0	200	800	40.0	960.0	447.21	552.79
2.2	220	780	48.4	951.6	469.04	530.96
2.4	240	760	57.6	942.4	489.90	510.10
2.6	260	740	67.6	932.4	509.90	490.10
2.8	280	720	78.4	921.6	529.15	470.85
3.0	300	700	90.0	910.0	547.72	452.28
3.2	320	680	102.4	897.6	565.69	434.31
3.4	340	660	115.6	884.4	583.10	416.90
3.6	360	640	129.6	870.4	600.00	400.00
3.8	380	620	144.4	855.6	616.44	383.56
4.0	400	600	160.0	840.0	632.46	367.54
4.2	420	580	176.4	823.6	648.07	351.93
4.4	440	560	193.6	806.4	663.32	336.68
4.6	460	540	211.6	788.4	678.23	321.77
4.8	480	520	230.4	769.6	692.82	307.18
5.0	500	500	250.0	750.0	707.11	292.89
5.2	520	480	270.4	729.6	721.11	278.89
5.4	540	460	291.6	708.4	734.85	265.15
5.6	560	440	313.6	686.4	748.33	251.67
5.8	580	420	336.4	663.6	761.58	238.42
6.0	600	400	360.0	640.0	774.60	225.40
6.2	620	380	384.4	615.6	787.40	212.60
6.4	640	360	409.6	590.4	800.00	200.00
6.6	660	340	435.6	564.4	812.40	187.60
6.8	680	320	462.4	537.6	824.62	175.38
7.0	700	300	490.0	510.0	836.66	163.34
7.2	720	280	518.4	481.6	848.53	151.47
7.4	740	260	547.6	452.4	860.23	139.77
7.6	760	240	577.6	422.4	871.78	128.22
7.8	780	220	608.4	391.6	883.18	116.82
8.0	800	200	640.0	360.0	894.43	105.57
8.2	820	180	672.4	327.6	905.54	94.46
8.4	840	160	705.6	294.4	916.52	83.48
8.6	860	140	739.6	260.4	927.36	72.64
8.8	880	120	774.4	225.6	938.08	61.92
9.0	900	100	810.0	190.0	948.68	51.32
9.2	920	80	846.4	153.6	959.17	40.83
9.4	940	60	883.6	116.4	969.54	30.46
9.6	960	40	921.6	78.4	979.80	20.20
9.8	980	20	960.4	39.6	989.95	10.05
10.0	1000	0	1000.0	0.0	1000.00	0.00

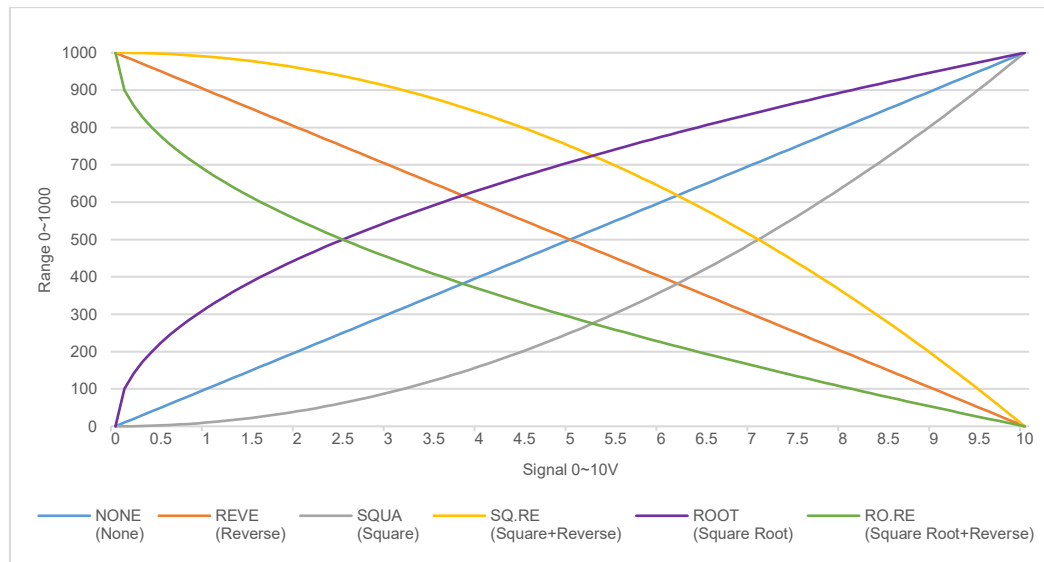

12. Alarm Action

Description

The FE controller can support up to three sets of alarm functions. Each set of alarms has 20 modes, except NONE, MSOK, and SOAK.

There are 6 active options for each mode. There are a total of more than 100 operating modes to choose

Users can choose the most suitable alarm mode according to their needs for system protection or application.

Function Diagram

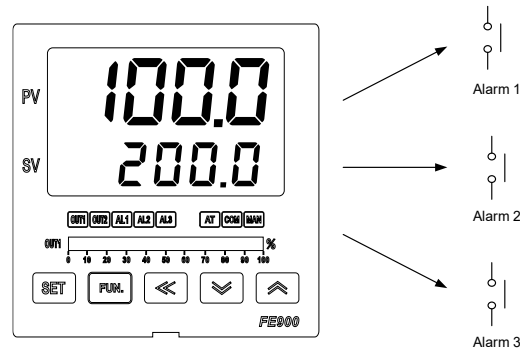

The related parameters of alarm function are as below:

Parameter	Symbol	Content	Range		Default	Level	Hide/Display
			MAX	MIN			
R_S	8888	RUN/STOP mode selection 0 : STOP (output & alarm disable) 1 : RUN (output & alarm enable)	RUN	STOP	RUN	Level 1	SET3.4
AL1H	8888	Alarm1 upper set value (ALD1 = DE.HI / DE.HL / BA.ND / PR.HI / DEHI / DEHL / BAND / PRHI appear)	USPL	-1999	1.0	Level 1	SET1.2
AL1L	8888	Alarm1 lower set value (ALD1 = DE.LO / DE.HL / BA.ND / PR.LO / DELO / DEHL / BAND / PRLO appear)	USPL	-1999	1.0	Level 1	SET1.2
AL2H	8888	Alarm2 upper set value (ALD2 = DE.HI / DE.HL / BA.ND / PR.HI / DEHI / DEHL / BAND / PRHI appear)	USPL	-1999	1.0	Level 1	SET1.3
AL2L	8888	Alarm2 lower set value (ALD2 = DE.LO / DE.HL / BA.ND / PR.LO / DELO / DEHL / BAND / PRLO appear)	USPL	-1999	1.0	Level 1	SET1.3
AL3H	8888	Alarm3 upper set value (ALD3 = DE.HI / DE.HL / BA.ND / PR.HI / DEHI / DEHL / BAND / PRHI appear)	USPL	-1999	1.0	Level 1	SET1.4
AL3L	8888	Alarm3 lower set value (ALD3 = DE.LO / DE.HL / BA.ND / PR.LO / DELO / DEHL / BAND / PRLO appear)	USPL	-1999	1.0	Level 1	SET1.4
ALD1	8888	Alarm1 mode selection (Please refer to Chapter 12.1 Alarm Mode)	FSOK	NONE	DEHI	Level 3	SET7.4
ALT1	8888	FLIK (00.00) : Flicker COTI (99.59) : Continued ON 00.01~99.58 : delay time	COTI	FLIK	COTI	Level 3	SET7.4
HYA1	8888	Hysteresis setting for alarm1	100.0	-100.0	1.0	Level 3	SET7.4
SEA1	5888	Alarm1 special function setting (Please refer to Chapter 12.2 Alarm Special Setting)	1111	0000	0000	Level 3	SET7.4
ALD2	8888	Alarm2 mode selection (Please refer to Chapter 12.1 Alarm Mode)	FSOK	NONE	NONE	Level 3	SET8.1
ALT2	8888	FLIK (00.00) : Flicker COTI (99.59) : Continued ON 00.01~99.58 : delay time	COTI	FLIK	COTI	Level 3	SET8.1
HYA2	8888	Hysteresis setting for alarm 2	100.0	-100.0	1.0	Level 3	SET8.1
SEA2	5888	Alarm2 special function setting (Please refer to Chapter 12.2 Alarm Special Setting)	1111	0000	0000	Level 3	SET8.1

The related parameters of alarm function are as below:

Parameter	Symbol	Content	Range		Default	Level	Hide/Display
			MAX	MIN			
ALD3	<i>8883</i>	Alarm3 mode selection (Please refer to Chapter 12.1 Alarm Mode)	FSOK	NONE	NONE	Level 3	SET8.2
ALT3	<i>8883</i>	FLIK (00.00) : Flicker COTI (99.59) : Continued ON 00.01~99.58 : delay time	COTI	FLIK	COTI	Level 3	SET8.2
HYA3	<i>8883</i>	Hysteresis setting for alarm 3	100.0	-100.0	1.0	Level 3	SET8.2
SEA3	<i>5883</i>	Alarm3 special function setting (Please refer to Chapter 12.2 Alarm Special Setting)	1111	0000	0000	Level 3	SET8.2

12.1 Alarm Mode

▲ : SV △ : Alarm set value X : 1 / 2 / 3 (There are up to 3 sets of alarms)

ALDX		Index value	Alarm mode	Description
NONE		0	No alarm function	Not drive any alarm relays and the corresponding LED lamp.
DE.HI		1	Deviation high (With hold action)	 Formula $PV \geq (SV + ALXH) \rightarrow \text{Alarm ON}$ $PV \leq (SV + ALXH - HYAX) \rightarrow \text{Alarm OFF}$
DE.LO		2	Deviation low (With hold action)	 Formula $PV \leq (SV + ALXL) \rightarrow \text{Alarm ON}$ $PV \geq (SV + ALXL + HYAX) \rightarrow \text{Alarm OFF}$
DE.HL		3	Deviation high/low (With hold action)	 Formula $PV \leq (SV + ALXL) \rightarrow \text{Alarm ON}$ $PV \geq (SV + ALXL + HYAX) \rightarrow \text{Alarm OFF}$ $PV \geq (SV + ALXH) \rightarrow \text{Alarm ON}$ $PV \leq (SV + ALXH - HYAX) \rightarrow \text{Alarm OFF}$
BA.ND		4	Band (With hold action)	 Formula $PV \leq (SV + ALXH) \rightarrow \text{Alarm ON}$ $PV > (SV + ALXH) \rightarrow \text{Alarm OFF}$ $PV \geq (SV + ALXL) \rightarrow \text{Alarm ON}$ $PV < (SV + ALXL) \rightarrow \text{Alarm OFF}$
PR.HI		5	Process high (With hold action)	 Formula $PV \geq ALXH \rightarrow \text{Alarm ON}$ $PV \leq (ALXH - HYAX) \rightarrow \text{Alarm OFF}$
PR.LO		6	Process low (With hold action)	 Formula $PV \leq ALXL \rightarrow \text{Alarm ON}$ $PV \geq (ALXL + HYAX) \rightarrow \text{Alarm OFF}$
PEND		7	Program end	When the program is end, the alarm action *This mode only available in program type controller
SYAB		8	System error	The alert action, when PV displays error message
HBA		9	HBA (Heater Break Alarm)	Activated conditions : 1. Heater current(HBCU) is less the HBSV set value 2. OUT1 manipulated value exceed HBOP set value 3. Fit with Condition1 and 2 and exceed set the seconds of HBTM

Hold Action

There is a dot on the led display for alarm hold action, such as \rightarrow (Deviation high with hold action)

When the controller boot completed, the PV is within the alarm range, and no alarm action will be generated at this time, until the PV exceed alarm range then enter the alarm range again the alarm will be activated.

12.1 Alarm Mode

▲ : SV △ : Alarm set value X : 1 / 2 / 3 (There are up to 3 sets of alarms)

ALDX		Index value	Alarm mode	Description
MSOK		10	soak timer	Boot completed, the alarm is ON. When PV ≥ target SV start the soak timer, alarm and control function are turned OFF in soak time finish please refer to chapter 11.10 RAMP + SOAK
DEHI		11	Deviation high	
			Formula	$PV \geq (SV + ALXH) \rightarrow \text{Alarm ON}$ $PV \leq (SV + ALXH - HYAX) \rightarrow \text{Alarm OFF}$
DELO		12	Deviation low	
			Formula	$PV \leq (SV + ALXL) \rightarrow \text{Alarm ON}$ $PV \geq (SV + ALXL + HYAX) \rightarrow \text{Alarm OFF}$
DEHL		13	Deviation high/low	
			Formula	$PV \leq (SV + ALXL) \rightarrow \text{Alarm ON}$ $PV \geq (SV + ALXL + HYAX) \rightarrow \text{Alarm OFF}$ $PV \geq (SV + ALXH) \rightarrow \text{Alarm ON}$ $PV \leq (SV + ALXH - HYAX) \rightarrow \text{Alarm OFF}$
BAND		14	Band	
			Formula	$PV \leq (SV + ALXH) \rightarrow \text{Alarm ON}$ $PV > (SV + ALXH) \rightarrow \text{Alarm OFF}$ $PV \geq (SV + ALXL) \rightarrow \text{Alarm ON}$ $PV < (SV + ALXL) \rightarrow \text{Alarm OFF}$
PRHI		15	Process high	
			Formula	$PV \geq ALXH \rightarrow \text{Alarm ON}$ $PV \leq (ALXH - HYAX) \rightarrow \text{Alarm OFF}$
PRLO		16	Process low	
			Formula	$PV \leq ALXL \rightarrow \text{Alarm ON}$ $PV \geq (ALXL + HYAX) \rightarrow \text{Alarm OFF}$
PRUN		17	Program run	When the program is being executed, the alarm action *This mode only available in program type controller
SYNO		18	System normal	The Alert action, when PV normal displays(no error message)
SOAK		19	Ramp Soak Timer	Boot completed, the alarm is ON 1. RAMP SV reach target SV 2. PV ≥ target SV When both above conditions are true start the soak timer, alarm and control function are turned OFF in soak time finish (in this function ramp function is necessary) please refer to chapter 11.10 RAMP + SOAK

12.1 Alarm Mode

▲ : SV △ : Alarm set value X : 1 / 2 / 3 (There are up to 3 sets of alarms)

ALDX		Index value	Alarm mode	Description
TIM		20	Timer	Alarm action in time up *This mode only available in Digital Input function
CNT		21	Counter	Alarm action after counter value is reached *This mode only available in Digital Input function
CUTM		22	24H Timer	When CUTM = ONTM, alarm activates When CUTM = OFTM, alarm stops
FSOK		23	soak timer	Boot completed, the alarm is OFF. when PV ≥ target SV start the soak timer, alarm is turned ON and the control function keep ON in soak time finish please refer to chapter 11.10 RAMP + SOAK
SEG		24	Segment execute alarm	When SEG=ALX alarm ON *This mode only available in program type controller

12.2 Alarm Special Setting

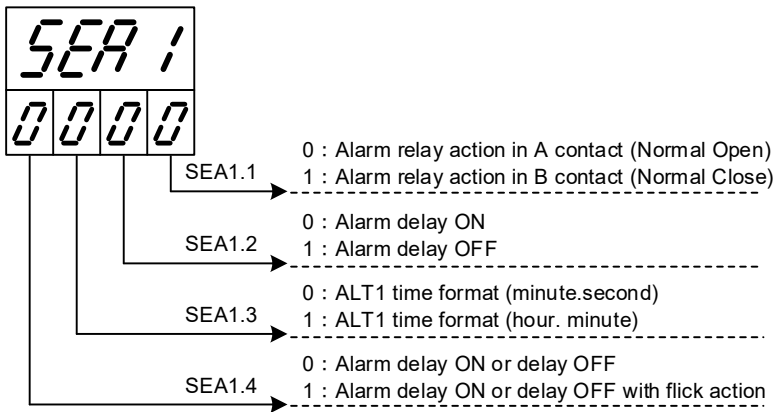

※ : Alarm Special Setting SEA1~SEA3

X : 1 / 2 / 3 (There are up to 3 sets of alarms)

SEAX	Status = 0	Status = 1
SEAX.1	Alarm relay action in A contact (Normal Open)	Alarm relay action in B contact (Normal Close)
	Alarm relay action same with alarm led 	Alarm relay action is the opposite of alarm led
SEAX.2	Alarm delay ON	Alarm delay OFF
	Conditions: When ALTX = 00.01~99.58 When PV entering the alarm range, the timer starts. At this time, the alarm led and relay keep original state, alarm led and relay change state in time up 	Conditions: When ALTX = 00.01~99.58 When PV entering the alarm range, the timer starts. At this time, the alarm led and relay change state, alarm led and relay change state again in time up
SEAX.3	ALTX time format (minutes.seconds) Ex : ALT1=33.23 , its time format is 33 minutes and 23 seconds	ALTX time format (hours. minutes) Ex : ALT1=33.23 , its time format is 33 hours and 23 minutes
SEAX.4	Alarm delay ON or delay OFF	Alarm delay ON or delay OFF with flick action
	When ALTX = 00.01~99.58, according to the SETA.2 setting value, the relay and alarm led will continue to operate when an alarm occurs SEAX.2=0 SEAX.2=1 	When ALTX = 00.01~99.58, according to the SETA.2 setting value, the relay and alarm led will flick when an alarm occurs SEAX.2=0 SEAX.2=1

12.3 Alarm Example

Example 1 : Deviation low, the difference between alarm hold action and without alarm hold action, shown in the diagram below

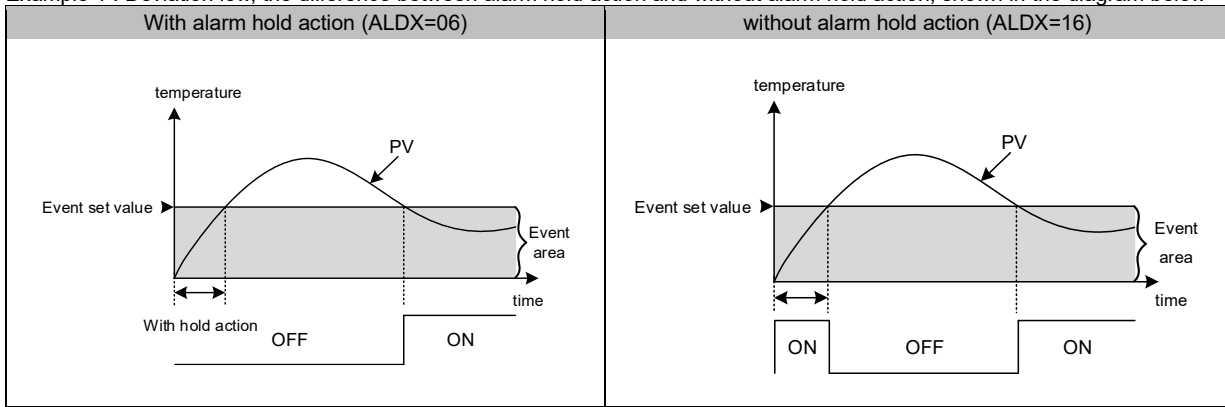

Example 2: Relative relevance between Alarm1 and ALT1 and SEA1

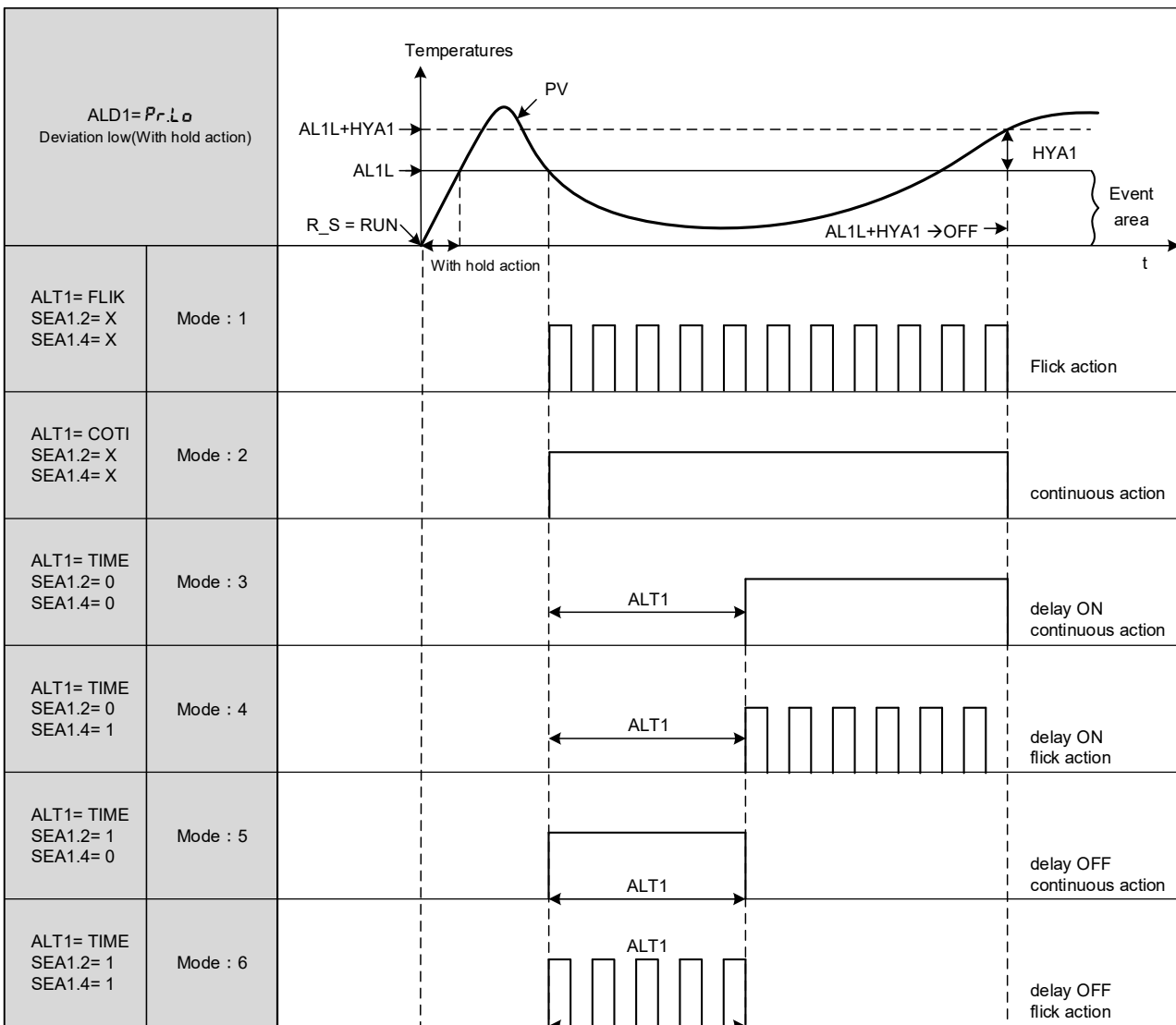

※ X : Don't care

13. Modification Of Output Module

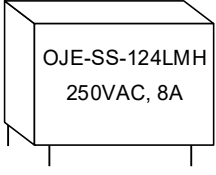
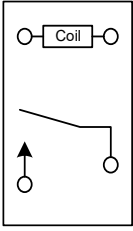

13.1 Relay Control (1a)

Side view	Bottom view	Software Setting
 <p>OJE-SS-124LMH 250VAC, 8A</p>	 <p>Coil</p>	<p>Parameter set as "CYT1 =10"</p>

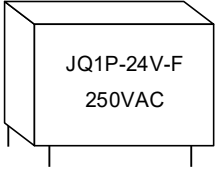
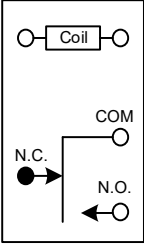
13.2 Relay Control (1c)

Side view	Bottom view	Software Setting
 <p>JQ1P-24V-F 250VAC</p>	 <p>Coil</p> <p>COM</p> <p>N.C.</p> <p>N.O.</p>	<p>Parameter set as "CYT1 =10"</p>

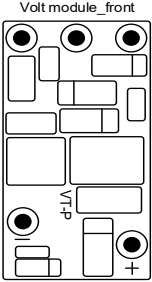
13.3 SSR Control

Top view	Bottom view	Software Setting
 <p>Volt module_front</p> <p>V+P</p> <p>+</p>	 <p>Volt module_back</p> <p>Pb</p> <p>VOLT_Pulse-K1712</p> <p>Made In Taiwan</p>	<p>Parameter set as "CYT1 =1"</p>

13.4 Linear Control

When modifying mA current module, output signal needs to be calibrated, and for detailed calibration procedure, please refer to [Chap. 13.5 Output Calibration Procedure Diagram](#)

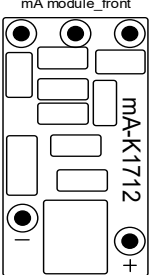
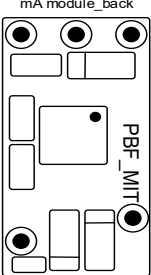
Top view	Bottom view	Software Setting
 <p>mA module_front</p> <p>mA-K1712</p> <p>+</p> <p>-</p>	 <p>mA module_back</p> <p>PBF_MITT</p>	<p>Parameter set as "CYT1 =0"</p>

13.5 Output Calibration Procedure Diagram

Output1 Signal (4mA~20mA) calibration flowchart

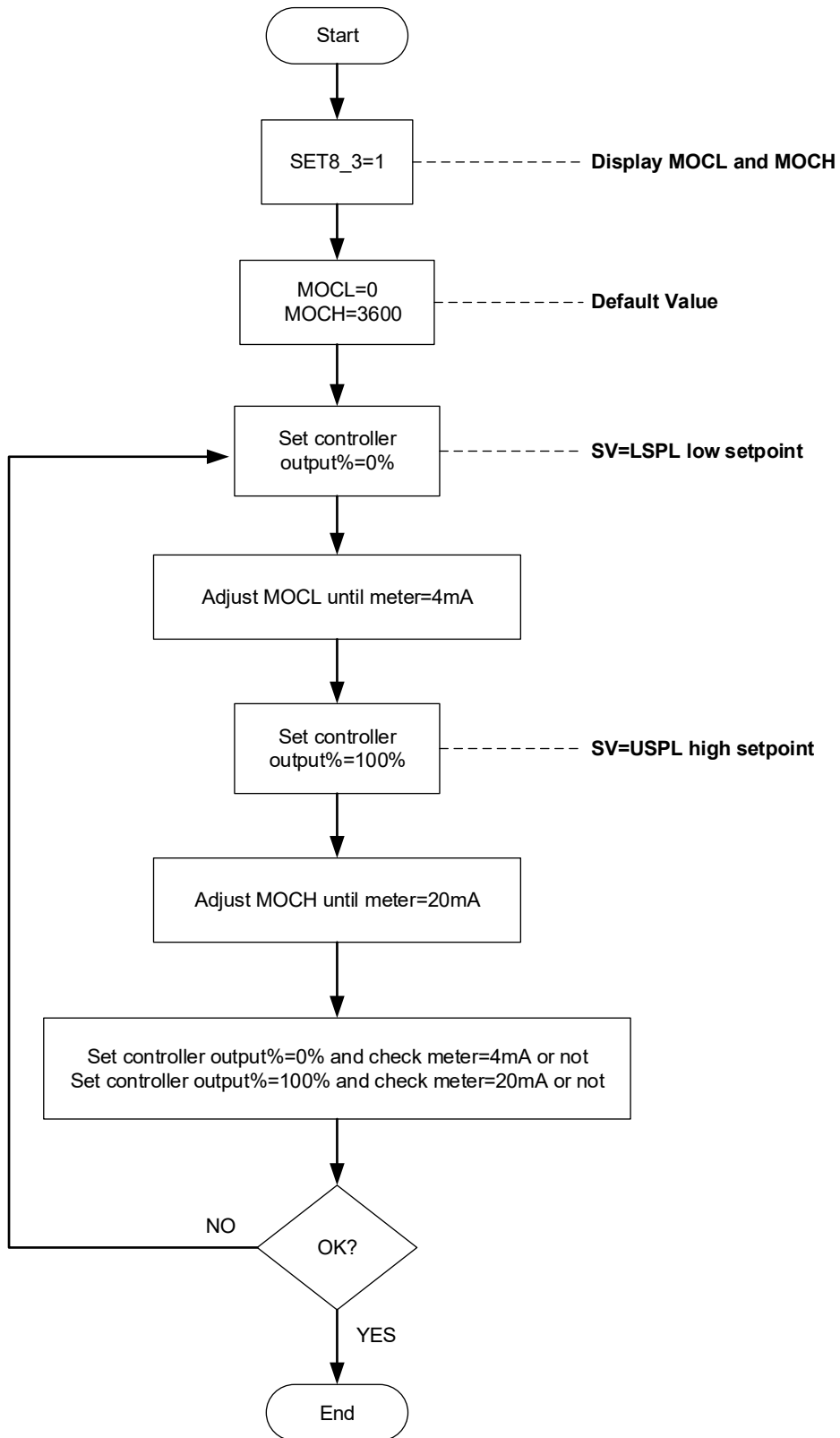

13.6 Output Calibration Steps

1. Display MOCL & MOCH :

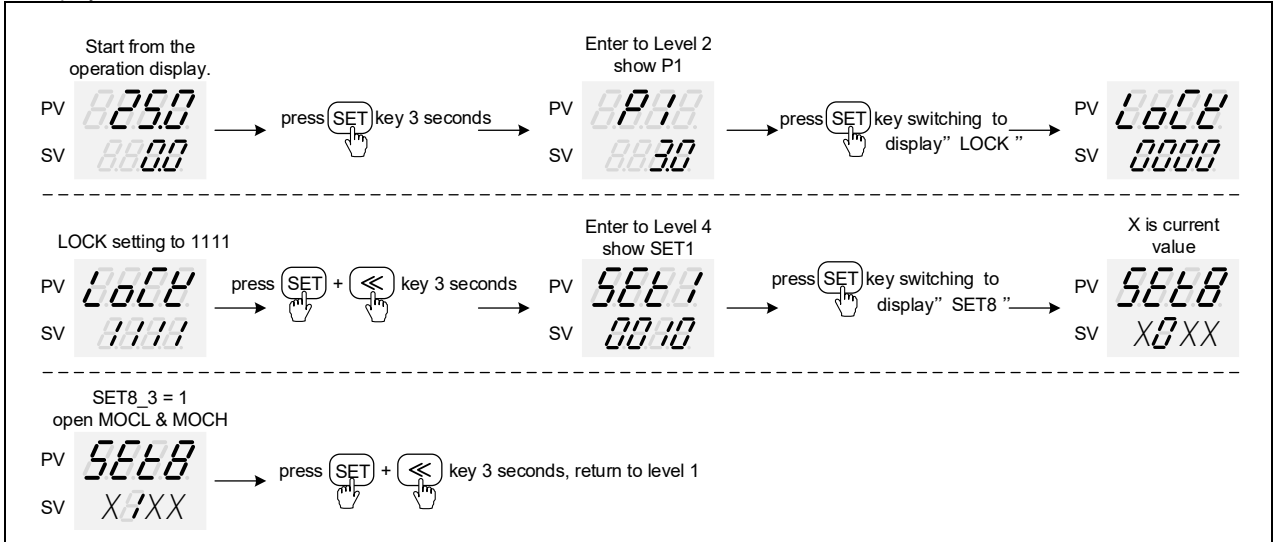

※ : X is default value which does not need to be modified

2. Adjust MOCL low-point calibration value :

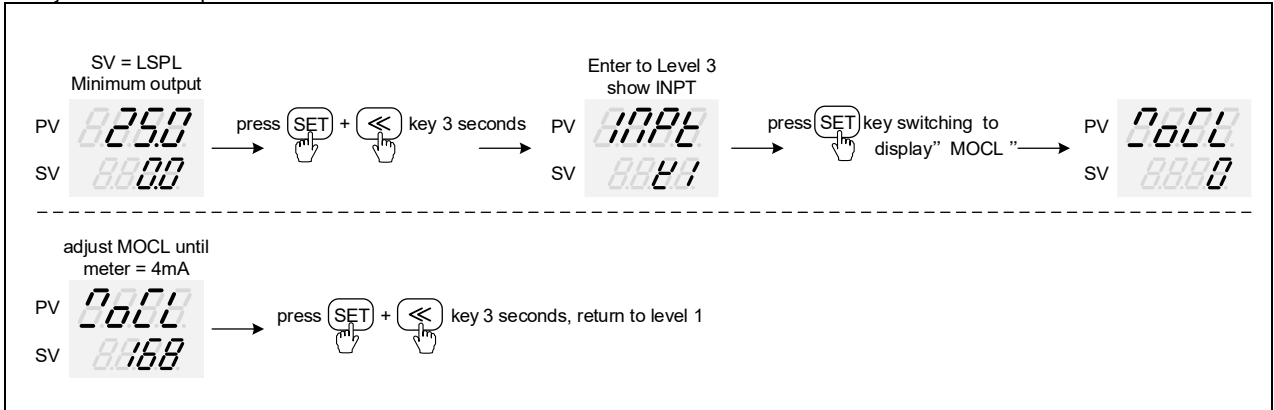

※ : MOCL calibration value of each controller is different from the other

3. Adjust MOCH high-point calibration value

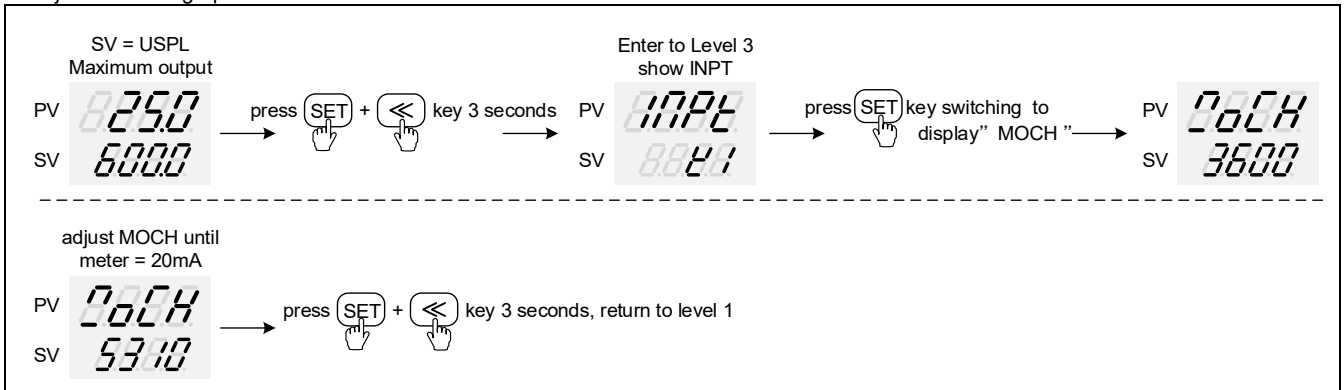

※ : MOCH calibration value of each controller is different from the other

14. Modification Of Input Signal

14.1 Input Modify To Thermocouple

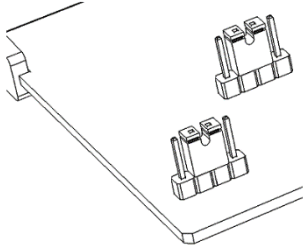
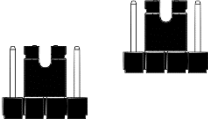
Jumper Position		Software Setting
Plug 2 pcs of Jumper into the middle slot as shown		
		Parameter set as "INPT=K1~L"

14.2 Input Modify To RTD

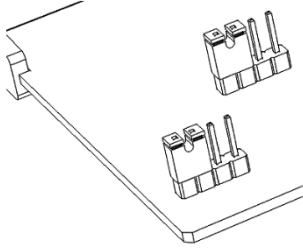
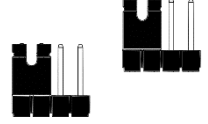
Jumper Position		Software Setting
Plug 2 pcs of Jumper into the left slot as shown		
		Parameter set "INPT=PT1~PT3"

14.3 Input Modify To Linear (4~20mA)

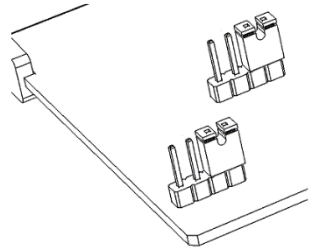
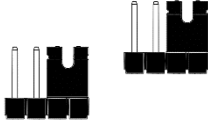
Jumper Position		Software Setting
Plug 2 pcs of Jumper into the right slot as shown		Parameter set as "INPT=AN4"
		

Linear analog signal (4~20mA) calibration flowchart

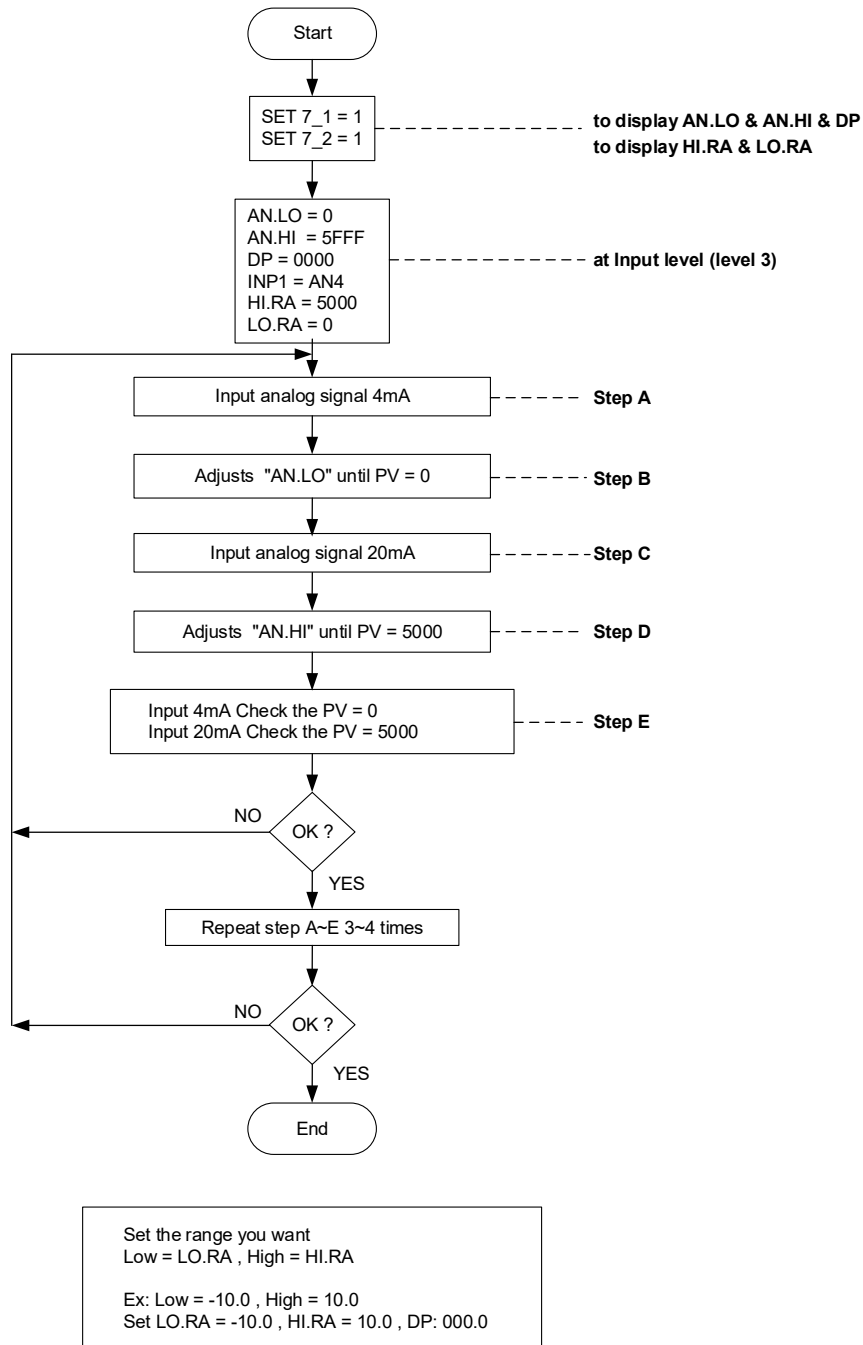

Notes

1. When TC/RTD input is modified to linear analog signal (4~20mA), input signal needs to be calibrated.
2. When linear analog signal (4~20mA) input is modified to TC/RTD, please memory current AN.LO and AN.HI value and recover AN.LO and AN.HI to default value (AN.LO = 0, AN.HI = 5FFF)

14.4 Steps For Input Calibration

1. Display AN.LO, AN.HI, DP :

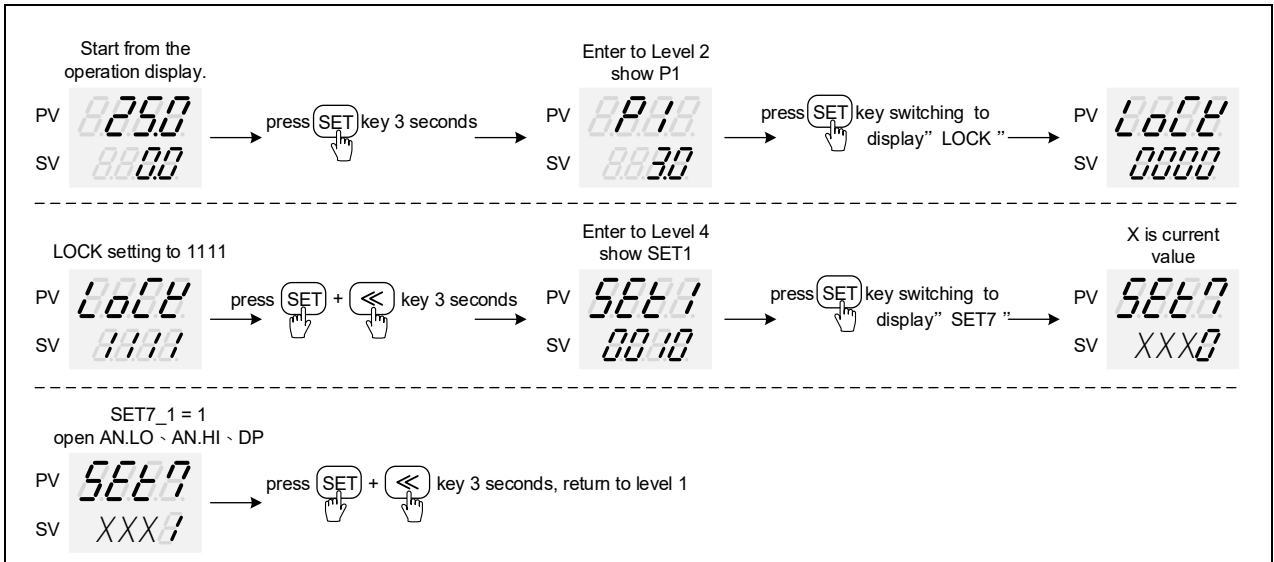

※ X is the default value which does not require modification

2. Adjustment of AN.LO calibration values

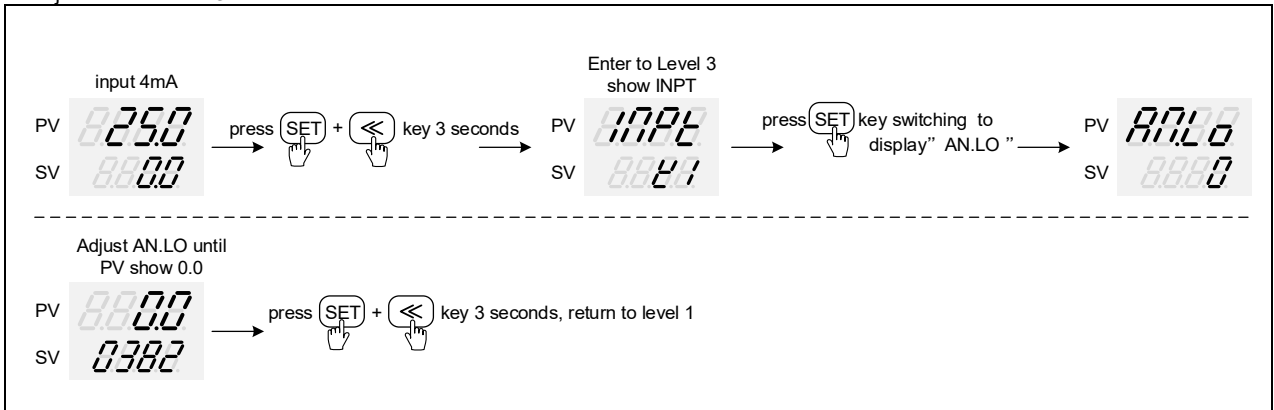

※ AN.LO calibration value of each controller is different from the other

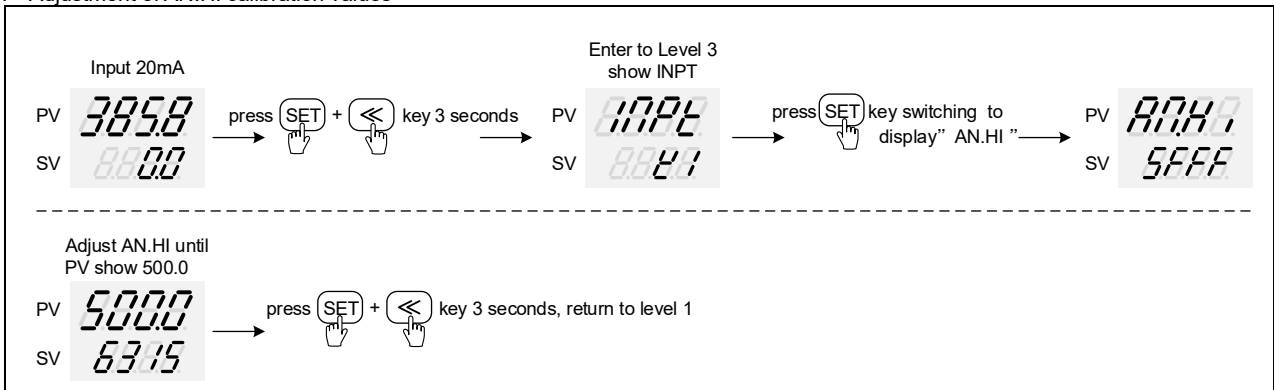

3. Adjustment of AN.HI calibration values





※ AN.HI calibration value of each controller is different from the other

15. Error Message

If controller exhibits any of the following issues, please proceed with the following procedures

Symbol	Error	Solution
	INIE: Input1 Error	Check whether input loop is opened or wiring is incorrect.
	UUUU: PV is above USPL	Check whether the input value is correct or not.
	NNNN: PV is below LSPL	Check whether the input value is correct or not.

If any of the indication in the table below appear, the controller need to be repaired do not try to repair the controller by yourself, order a new one or contact us to repair.

Symbol	Error	Solution
	ADCF: A/D convert failed	Please send for repair.
	CJER: Cold junction compensation failed	Please send for repair.
	RAMF: EEPROM failed	Please send for repair.

16. FE Communication Register Address Table

RMAP = OFF

Parameter	Register Address		R / W
	Hex	Dec	
PV	0x00	0	R
SV	0x01	1	R / W
LOOP	0x02	2	R / W
R S	0x03	3	R / W
HBCU	0x04	4	R
HBSV	0x05	5	R / W
HBTM	0x06	6	R / W
AL1H	0x07	7	R / W
AL1L	0x08	8	R / W
AL2H	0x09	9	R / W
AL2L	0x0A	10	R / W
AL3H	0x0B	11	R / W
AL3L	0x0C	12	R / W
SV1	0x0D	13	R / W
SV2	0x0E	14	R / W
SV3	0x0F	15	R / W
SV4	0x10	16	R / W
TIM	0x11	17	R / W
CNT	0x12	18	R / W
CUTM	0x13	19	R / W
ONTM	0x14	20	R / W
OFTM	0x15	21	R / W
A_M	0x16	22	R / W
MOUT	0x17	23	R / W
AT	0x18	24	R / W
RATE	0x19	25	R / W
RAMP	0x1A	26	R / W
SOAK	0x1B	27	R / W
WAIT	0x1C	28	R / W
DTM1	0x1D	29	R / W
DTM2	0x1E	30	R / W
DTM3	0x1F	31	R / W
DTM4	0x20	32	R / W
DT.ST	0x21	33	R / W
PTN	0x22	34	R
SEG	0x23	35	R
L1SV	0x24	36	R
L2SV	0x25	37	R
TIMR	0x26	38	R
DOUT	0x27	39	R / W
P1	0x28	40	R / W
M_LP	0x29	41	R / W
I1	0x2A	42	R / W
M LI	0x2B	43	R / W
D1	0x2C	44	R / W
M LD	0x2D	45	R / W
HYS1	0x2E	46	R / W
CYT1	0x2F	47	R / W

Parameter	Register Address		R / W
	Hex	Dec	
MOLH	0x30	48	R / W
MOLL	0x31	49	R / W
P2	0x32	50	R / W
S LP	0x33	51	R / W
I2	0x34	52	R / W
S LI	0x35	53	R / W
D2	0x36	54	R / W
S LD	0x37	55	R / W
HYS2	0x38	56	R / W
CYT2	0x39	57	R / W
SOLH	0x3A	58	R / W
SOLL	0x3B	59	R / W
MGAP	0x3C	60	R / W
SGAP	0x3D	61	R / W
COUT	0x3E	62	R
AT.VL	0x3F	63	R / W
SS.PO	0x40	64	R / W
OPSF	0x41	65	R / W
RC.TO	0x42	66	R / W
LOCK	0x43	67	R / W
INPT	0x44	68	R / W
AN.LO	0x45	69	R / W
AN.HI	0x46	70	R / W
DP	0x47	71	R / W
HI.RA	0x48	72	R / W
LO.RA	0x49	73	R / W
USPL	0x4A	74	R / W
LSPL	0x4B	75	R / W
ALD1	0x4C	76	R / W
ALT1	0x4D	77	R / W
HYA1	0x4E	78	R / W
SEA1	0x4F	79	R / W
ALD2	0x50	80	R / W
ALT2	0x51	81	R / W
HYA2	0x52	82	R / W
SEA2	0x53	83	R / W
ALD3	0x54	84	R / W
ALT3	0x55	85	R / W
HYA3	0x56	86	R / W
SEA3	0x57	87	R / W
MOCL	0x58	88	R / W
MOCH	0x59	89	R / W
SOCL	0x5A	90	R / W
SOCH	0x5B	91	R / W
MV.SF	0x5C	92	R / W
RC.TI	0x5D	93	R / W
UNIT	0x5E	94	R / W
OUTM	0x5F	95	R / W

16. FE Communication Register Address Table

RMAP = OFF

Parameter	Register Address		R / W
	Hex	Dec	
SV.OS	0x60	96	R / W
PV.OS	0x61	97	R / W
PV.OH	0x62	98	R / W
MLNB	0x63	99	R / W
COMP	0x64	100	R / W
OFFS	0x65	101	R / W
SV.TY	0x66	102	R / W
OU.TY	0x67	103	R / W
PMAC	0x68	104	R / W
FKSL	0x69	105	R / W
BASE	0x6A	106	R / W
TP_K	0x6B	107	R / W
TMSL	0x6C	108	R / W
MVRT	0x6D	109	R / W
HYSM	0x6E	110	R / W
RH.TC	0x6F	111	R / W
RH.PO	0x70	112	R / W
RH.TM	0x71	113	R / W
PR.SV	0x72	114	R / W
AT.SV	0x73	115	R / W
SET1	0x74	116	R / W
SET2	0x75	117	R / W
SET3	0x76	118	R / W
SET4	0x77	119	R / W
SET5	0x78	120	R / W
SET6	0x79	121	R / W
SET7	0x7A	122	R / W
SET8	0x7B	123	R / W
SET9	0x7C	124	R / W
SETA	0x7D	125	R / W
SETB	0x7E	126	R / W
SETC	0x7F	127	R / W
SETD	0x80	128	R / W
SETE	0x81	129	R / W
SETF	0x82	130	R / W
HZ	0x106	262	R / W
PRTO	0x107	263	R
FOMA	0x108	264	R
IDNO	0x109	265	R
BAUD	0x10A	266	R
RPDT	0x10B	267	R / W
AOEN	0x10C	268	R / W

Parameter	Register Address		R / W
	Hex	Dec	
AOSL	0x10D	269	R / W
AO.LO	0x10E	270	R / W
AO.HI	0x10F	271	R / W
AOCL	0x110	272	R / W
AOCH	0x111	273	R / W
CTRT	0x112	274	R / W
D1SL	0x113	275	R / W
D2SL	0x114	276	R / W
REMO	0x115	277	R / W
CJSL	0x116	278	R / W
CJMN	0x117	279	R / W
CJTC	0x118	280	R / W
W_MD	0x119	281	R
RMAP	0x11A	282	R / W
OPSL	0x11B	283	R / W
POTM	0x11C	284	R / W
PTMD	0x11D	285	R / W
PVST	0x11E	286	R / W
REPT	0x11F	287	R / W
POWF	0x120	288	R / W
D01	0x121	289	R / W
D02	0x122	290	R / W
D03	0x123	291	R / W
D04	0x124	292	R / W
D05	0x125	293	R / W
D06	0x126	294	R / W
D07	0x127	295	R / W
D08	0x128	296	R / W
D09	0x129	297	R / W
D10	0x12A	298	R / W
D11	0x12B	299	R / W
D12	0x12C	300	R / W
D13	0x12D	301	R / W
D14	0x12E	302	R / W
D15	0x12F	303	R / W
D16	0x130	304	R / W
D17	0x131	305	R / W
D18	0x132	306	R / W
D19	0x133	307	R / W
D20	0x134	308	R / W

18. FE(Old) Communication Register Address Table

RMAP = FE

Parameter	Register Address		R / W
	Hex	Dec	
SV	0x00	0	R / W
PV	0x01	1	R
SV2	0x02	2	R / W
PV2	0x03	3	R
HBAC	0x04	4	R / W
HBAT	0x05	5	R / W
R-S	0x06	6	R / W
OLH1	0x07	7	R / W
OLL1	0x08	8	R / W
OLH2	0x09	9	R / W
OLL2	0x0A	10	R / W
AT	0x0B	11	R / W
AL1H	0x0C	12	R / W
AL1L	0x0D	13	R / W
AL2H	0x0E	14	R / W
AL2L	0x0F	15	R / W
AL3H	0x10	16	R / W
AL3L	0x11	17	R / W
SV_1	0x12	18	R / W
SV_2	0x13	19	R / W
SV_3	0x14	20	R / W
A-M	0x15	21	R / W
MOP	0x16	22	R / W
P1	0x35	53	R / W
I1	0x36	54	R / W
D1	0x37	55	R / W
CYT1	0x38	56	R / W
SOF1	0x39	57	R / W
HYO1	0x3A	58	R / W
OP1	0x3B	59	R
P2	0x3C	60	R / W
I2	0x3D	61	R / W
D2	0x3E	62	R / W
CYT2	0x3F	63	R / W
SOF2	0x40	64	R / W
GAP.1	0x41	65	R / W
GAP.2	0x42	66	R / W
HYO2	0x43	67	R / W
OP2	0x44	68	R
ATVL	0x45	69	R / W
LCK	0x4B	75	R / W
INP1	0x4C	76	R / W
ANL1	0x4D	77	R / W
ANH1	0x4E	78	R / W
DP	0x4F	79	R / W
LSPL	0x50	80	R / W
USPL	0x51	81	R / W
SVL1	0x52	82	R / W
SVH1	0x53	83	R / W
PLL1	0x54	84	R / W
PHH1	0x55	85	R / W
ALD1	0x56	86	R / W
ALT1	0x57	87	R / W
HYS1	0x58	88	R / W
ALD2	0x59	89	R / W
ALT2	0x5A	90	R / W
HYS2	0x5B	91	R / W
ALD3	0x5C	92	R / W
ALT3	0x5D	93	R / W
HYS3	0x5E	94	R / W
SETA	0x5F	95	R / W
CLO1	0x60	96	R / W
CHO1	0x61	97	R / W
CLO2	0x62	98	R / W
CHO2	0x63	99	R / W
TE	0x64	100	R / W
TS	0x65	101	R / W
TSPL	0x66	102	R / W
TSPH	0x67	103	R / W

Parameter	Register Address		R / W
	Hex	Dec	
CLO3	0x68	104	R / W
CHO3	0x69	105	R / W
RUCY	0x6A	106	R / W
WAIT	0x6B	107	R / W
PSL	0x6C	108	R / W
BITS	0x6D	109	R / W
IDNO	0x6E	110	R / W
BAUD	0x6F	111	R / W
INT	0x70	112	R / W
SVOS	0x71	113	R / W
PVOS	0x72	114	R / W
PVOH	0x73	115	R / W
PVFT	0x74	116	R / W
UNIT	0x75	117	R / W
OUD	0x76	118	R / W
HZ	0x77	119	R / W
INP2	0x78	120	R / W
ANL2	0x79	121	R / W
ANH2	0x7A	122	R / W
DP_2	0x7B	123	R / W
LSP2	0x7C	124	R / W
USP2	0x7D	125	R / W
SVL2	0x7E	126	R / W
SVH2	0x7F	127	R / W
PLL2	0x80	128	R / W
PHH2	0x81	129	R / W
SVO2	0x82	130	R / W
PVS2	0x83	131	R / W
PVH2	0x84	132	R / W
PVF2	0x85	133	R / W
UNI2	0x86	134	R / W
FKSL	0x87	135	R / W
DIE	0x8C	140	R / W
DIS	0x8D	141	R / W
SET1	0x8E	142	R / W
SET2	0x8F	143	R / W
SET3	0x90	144	R / W
SET4	0x91	145	R / W
SET5	0x92	146	R / W
SET6	0x93	147	R / W
SET7	0x94	148	R / W
SET8	0x95	149	R / W
SET9	0x96	150	R / W
SET0	0x97	151	R / W
OUTY	0x9D	157	R / W
R-M	0x9E	158	R / W
CJS	0x9F	159	R / W
CJM	0xA0	160	R / W
CJT	0xA1	161	R
OBIT	0xA2	162	R
D_01	0xA5	165	R / W
D_02	0xA6	166	R / W
D_03	0xA7	167	R / W
D_04	0xA8	168	R / W
D_05	0xA9	169	R / W
D_06	0xAA	170	R / W
D_07	0xAB	171	R / W
D_08	0xAC	172	R / W
D_09	0xAD	173	R / W
D_10	0xAE	174	R / W
D_11	0xAF	175	R / W
D_12	0xB0	176	R / W
D_13	0xB1	177	R / W
D_14	0xB2	178	R / W
D_15	0xB3	179	R / W
D_16	0xB4	180	R / W

19. Glossary Of Characters Used In This Manual

LED Display										
Characters	0	1	2	3	4	5	6	7	8	9
LED Display										
Characters	A	B	C	D	E	F	G	H	I	J
LED Display										
Characters	K	L	M	N	O	P	Q	R	S	T
LED Display										
Characters	U	V	W	X	Y	Z	°C	°F		

20. FE Parameter Abbreviation Descriptions

PV	Process value
SV	Set value
LOOP	Loop
R S	Run_Stop
HBCU	Heater Break Current
HBSV	Heater Break SV
HBTM	Heater Break timer
AL1H	Alarm 1 high value
AL1L	Alarm 1 low value
AL2H	Alarm 2 high value
AL2L	Alarm 2 low value
AL3H	Alarm 3 high value
AL3L	Alarm 3 low value
SV1~SV4	Set value 1~4
TIM	Timer
CNT	Counter
CUTM	Current time
ONTM	ON time
OFTM	OFF time
A M	Auto_manual
MOU	Manual out
AT	Control mode
RATE	Rate
RAMP	Ramp
SOAK	Soak
WAIT	Program action waiting for temperature
DTM1~DTM4	Do timer 1~4
DT.ST	Do timer set
PTN	Pattern
SEG	Segment
L1SV	Loop 1 SV
L2SV	Loop 2 SV
TIMR	Use for program
DOUT	Digit out
P1	Main proportional band
M_LP	Main low proportional band
I1	Main integral
M_LI	Main low integral
D1	Main differential
M_LD	Main low differential
HYS1	Main hysteresis
CYT1	Main cycle time
MOLH	Main output limit high
MOLL	Main output limit low
P2	Sub proportional band
S_LP	Sub low proportional band
I2	Sub integral
S_LI	Sub low integral
D2	Sub differential
S_LD	Sub low differential
HYS2	Sub hysteresis
CYT2	Sub cycle time
SOLH	Sub output limit high
SOLL	Sub output limit low
MGAP	Main gap
SGAP	Sub gap
COU	Current output
AT.VL	Autotune offset value
SS.PO	Steady state power
OPSF	Output special function
RC.TO	Low pass filter RC const.time for output
LOCK	Lock
INPT	Input type
AN.LO	Analog input calibrate low
AN.HI	Analog input calibrate high
DP	Point
HI.RA	High range
LO.RA	Low range
USPL	Upper set point limit
LSPL	Lower set point limit
ALD1	Alarm 1 mode
ALT1	Alarm 1 timer
HYA1	Hysteresis for alarm 1
SEA1	Special function for alarm 1
ALD2	Alarm 2 mode

20. FE Parameter Abbreviation Descriptions

ALT2	Alarm 2 timer
HYA2	Hysteresis for alarm 2
SEA2	Special function for alarm 2
ALD3	Alarm 3 mode
ALT3	Alarm 3 timer
HYA3	Hysteresis for alarm 3
SEA3	Special function for alarm 3
MOCL	Main output calibrate low
MOCH	Main output calibrate high
SOCL	Sub output calibrate low
SOCH	Sub output calibrate high
MV.SF	mV special function for input
RC.TI	Low pass filter RC const.time for input
UNIT	Unit
OUTM	Output mode
SV.OS	SV offset
PV.OS	PV offset
PV.OH	PV offset high
MLNB	Manual linearize number
COMP	Compare for manual linearize
OFFS	Offset for manual linearize
SV.TY	SV type
OU.TY	Output type
PMAC	Process RC const.Gain
FKSL	function key select
BIAS	---
TP_K	---
TMSL	Timer mode select
MVRT	Motor value run time
HYSM	Hysteresis for motor value
RH.TC	(Relative humidity) temperature of except wet
RH.PO	(Relative humidity) power of except wet
RH.TM	(Relative humidity) time of except wet
PR.SV	Pretune SV
AT.SV	Autotune SV
SET1	---
SET2	---
SET3	---
SET4	---
SET5	---
SET6	---
SET7	---
SET8	---
SET9	---
SETA	---
SETB	---
SETC	---
SETD	---
SETE	---
SETF	---
HZ	HZ
PRTO	Protocol
FOMA	Data format
IDNO	ID number
BAUD	Baud rate
RPDT	Response Delay time
AOEN	Analog output enable
AOSL	Analog output signal select
AO.LO	Analog output scale low
AO.HI	Analog output scale high
AOCL	Analog output calibrate low
AOCH	Analog output calibrate high
CTRT	Current transformer ratio
D1SL	Digital input 1 select
D2SL	Digital input 2 select
REMO	Program remote control
CJSL	Cold junction select
CJMN	Manual set cold junction
CJTC	Cold junction temperature
W_MD	Write mode for uart
RMAP	Register mapping
OPSL	Output select
POTM	Power ON delay time

20. FE Parameter Abbreviation Descriptions

PTMD	Program time mode
PVST	PV start
REPT	Repeat
POWF	Power failure