

**1 YEAR**  
WARRANTY



# User's Guide

**Shop online at**

**omega.com<sup>®</sup>**  
Ω OMEGA<sup>®</sup>

**omega.com**

**e-mail: info@omega.com**

**For latest product manuals:  
omegamanual.info**

**ISO 9001**  
CERTIFIED  
CORPORATE QUALITY  
STAMFORD, CT

**ISO 9001**  
CERTIFIED  
CORPORATE QUALITY  
MANCHESTER, UK

MADE IN TAIWAN



## PHCN-961 pH/ORP Controller



**OMEGAnet® Online Service**  
**omega.com**

**Internet e-mail**  
**info@omega.com**

### **Servicing North America:**

**U.S.A.:**  
ISO 9001 Certified

OMEGA Engineering, Inc.  
One Omega Drive  
P.O. Box 4047  
Stamford, CT 06907-0047 USA  
Toll-Free: 1-800-826-6342  
FAX: (203) 359-7700  
TEL: (203) 359-1660  
e-mail: info@omega.com

**Canada:**

976 Bergar  
Laval (Quebec), H7L 5A1 Canada  
Toll-Free: 1-800-826-6342  
FAX: (514) 856-6886  
TEL: (514) 856-6928  
e-mail: info@omega.ca

### **For immediate technical or application assistance:**

**U.S.A. and Canada:** Sales Service: 1-800-826-6342/1-800-TC-OMEGA®  
Customer Service: 1-800-622-2378 /1-800-622-BEST®  
Engineering Service: 1-800-872-9436/1-800-USA-WHEN®

**Mexico/  
Latin America**

En Español: 001 (203) 359-7803  
info@omega.com.mx  
FAX: 001 (203) 359-7807  
e-mail: espanol@omega.com

### **Servicing Europe:**

**Benelux:**

Managed by the United Kingdom Office  
Toll-Free: 0800 099 3344  
FAX: +31 20 643 46 43  
TEL: +31 20 347 21 21  
e-mail: sales@omegaeng.nl

**Czech Republic:**

Frystatska 184  
733 01 Karviná, Czech Republic  
Toll-Free: 0800-1-66342  
FAX: +420-59-6311114  
TEL: +420-59-6311899  
e-mail: info@omegashop.cz

**France:**

Managed by the United Kingdom Office  
Toll-Free: 0800 466 342  
FAX: +33 (0) 130 57 54 27  
TEL: +33 (0) 161 37 29 00  
e-mail: sales@omega.fr

**Germany/Austria:**

Daimlerstrasse 26  
D-75392 Deckenpfronn, Germany  
Toll-Free: 0800 6397678  
FAX: +49 (0) 7056 9398-29  
TEL: +49 (0) 7056 9398-0  
e-mail: info@omega.de

**United Kingdom:**

ISO 9001 Certified

OMEGA Engineering Ltd.  
One Omega Drive, River Bend Technology Centre, Northbank  
Irlam, Manchester M44 5BD United Kingdom  
Toll-Free: 0800-488-488  
FAX: +44 (0) 161 777-6622  
TEL: +44 (0) 161 777-6611  
e-mail: sales@omega.co.uk

It is the policy of OMEGA Engineering, Inc. to comply with all worldwide safety and EMC/EMI regulations that apply. OMEGA is constantly pursuing certification of its products to the European New Approach Directives. OMEGA will add the CE mark to every appropriate device upon certification.

The information contained in this document is believed to be correct, but OMEGA accepts no liability for any errors it contains, and reserves the right to alter specifications without notice.

**WARNING:** These products are not designed for use in, and should not be used for, human applications.

## Preface -

This manual serves to explain the use of **PHCN-961** series controller / transmitter. This instruction manual is written to cover as many anticipated applications of **PHCN-961** series controller / transmitter.

The information presented in this manual is subject to change without notice as improvements are made, and does not represent a commitment of part of **OMEGA ENGINEERING**.

**OMEGA ENGINEERING**. can not accept any responsibility for damage or malfunction of the unit due to improper use of the instrument..

**Copyright©2011 OMEGA ENGINEERING, All right reserved.**

---

## SAFETY INFORMATION

**OMEGA ENGINEERING. Controller / Transmitter shall be installed and operated only in the manner specified in the Instruction manual. Only skilled, trained or authorized person should carry out installation, setup and operation of the instrument.**

**Before powering up the unit, make sure that power source is connected to, is as specified in the top label. Failure to do so may result in a permanent damage to the unit.**



**Protect level against electric shock mainly depends on relevant installation rules.**

# TABLE OF CONTENTS

<u>1 PREFACE</u>	<u>7</u>
<u>BEFORE USE</u>	7
<u>IN USE</u>	7
<u>SAFETY INSTRUCTION</u>	8
<u>2 PRODUCT DESCRIPTION</u>	<u>9</u>
<u>2.1 DESCRIPTION OF INSTRUMENT SPECIALITY:</u>	9
<u>2.2 MEASUREMENT AND CONTROL SYSTEM</u>	10
<u>2.3 APPEARANCE</u>	11
<u>2.3.1 INTRODUCTION OF DISPLAY</u>	12
<u>2.3.2 KEY INSTRUCTION</u>	13
<u>2.3.3 LED INDUCTION</u>	13
<u>2.3.4 PASSWORD</u>	13
<u>2.3.5 PREVIEW OF FUNCTION</u>	14
<u>3 INSTALLATION AND ACCESSORY</u>	<u>15</u>
<u>INSTALLATION</u>	15
<u>PHCN-961 CONNECTION DIAGRAM</u>	16
<u>MEASUREMENT MODE</u>	17
<u>4 CALIBRATION MODE</u>	<u>18</u>
<u>4.1 ENTERING CALIBRATION MODE</u>	18
<u>4.2 pH CALIBRATION</u>	19
<u>4.3 ORP-mV CALIBRATION</u>	22
<u>5 SET UP MODE</u>	<u>23</u>
<u>ENTERING SET UP MODE</u>	23
<u>5.1 P01 TEMPERATURE SET-UP SUB-FUNCTION</u>	24
<u>5.2 P02 OFFSET SET-UP SUB-FUNCTION</u>	25
<u>5.3 P03: OUTPUT ELECTRIC CIRCUIT SP1/SP2 SUB-FUNCTION</u>	26
<u>5.4 P04 CONTROL MODE SUB-FUNCTION</u>	27
<u>5.5 P05 RELAY 1 SET-UP SUB-FUNCTION</u>	28
<u>5.6 P06 RELAY 2 SET-UP SUB-FUNCTION</u>	29
<u>5.7 P07 ALARM RELAY 3 SET-UP SUB-FUNCTION</u>	30
<u>5.8 P08 pH/ORP AND SENSOR CONFIGURATION SUB-FUNCTION</u>	31

---

5.9	<a href="#">P09 TRANSMITTING RATE SUB FUNCTION</a>	32
5.10	<a href="#">P10 REVERTING TO FACTORY DEFAULT SETTINGS</a>	33
5.11	<a href="#">COMMUNICATION PROTOCOL</a>	34
6	<a href="#">TECHNICAL PARAMETERS</a>	38
6.1	<a href="#">TECHNICAL PARAMETERS FORM</a>	38
6.2	<a href="#">PARAMETER SETTING AND FACTORY PRELIMINARY VALUE</a>	39
	<a href="#">APPENCLIX 2 – pH TEMPERATURE CORRESPONDING TO pH BUFFER SOLUTION</a>	40
	<a href="#">APPENCLIX 3 – HYSTERESIS BAND</a>	41
	<a href="#">APPENCLIX 4 – CONTROL MOVEMENT</a>	42
	<a href="#">ACCESSORY 5 – ABBREVIATIONS IN FUNCTION FORM</a>	44

---

---

## 1 PREFACE

---



---

### BEFORE USE

Thank you for using **OMEGA ENGINEERING. PHCN-961** series controllers and transmitters.

Although this series of pH/OPR controllers / transmitters use advanced technology and meet the requirements of current safety rules, improper use can also threaten the safety of users, and / or cause harmful influences to factory and other equipments. Therefore, before using pH/ORP controllers / transmitters, a qualified person must read and understand contents of this instruction manual.

Following symbols used in this instruction manual are to mark safety instruction and appendix information:

	<b>This symbol means safety instructions and warning of potential danger. If they are neglected, person may be harmed and property may be damaged.</b>
	<b>This symbol means the contents are technical notes, limitations or requirements. If they are neglected, it will cause low efficient and even losing products.</b>

Instruction manual should be kept accessible to the person who will use the use pH/ORP controller/ transmitter.

If you have problems, which are not mentioned in this manual, please contact Omega Engineering.

### IN USE



**OMEGA ENGINEERING. pH/ORP** controllers / transmitters, as described instruction manual, are intended to display pH or ORP and temperature measurement.

Any other uses, not mentioned in instruction manual, are not acceptable.

Other conditions of proper use include:

- Read and follow remarks and requirements stated in instruction manual.
- Follow local safety regulations for safe operation.
- Follow information and warning of products that are used together with the transmitters. (Chassis, electrode, etc.)
- Follow all environmental and working condition requirements.

## SAFETY INSTRUCTION

	<p>pH / ORP transmitters should be installed and operated by qualified person.</p>
	<p>Transmitters with problems should not be installed and/or used.</p>
	<p>pH / ORP transmitters should be used under acceptable working conditions.</p>
	<p>pH / ORP transmitters should not be open and repaired by clients themselves.</p>
	<p>Modified pH / ORP transmitters should not be used. Producers and suppliers do not bear responsibility for the damage and lose caused by modifying instruments without permission. Clients bear all the risks.</p> <p>This instrument has a protection level of IP65. Use waterproof cable glands when you connect the cable. Also, loosen the gland when you open the cover. After connecting the line, please tighten the cable connector with attached line tie, or it can cause damage when the cover is opened.</p> <p> Please make sure to disconnect the power before you open the cover.</p>

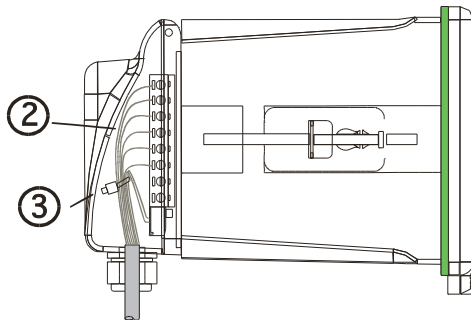
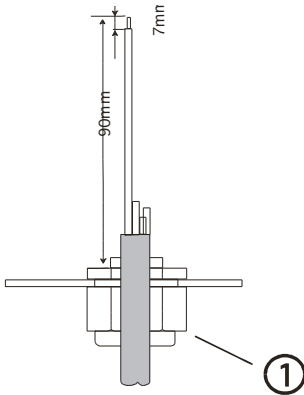

1. Cable glands
2. Cable (recommended stripping lengths for cables at least 90mm)
3. Cable ties



---

---

## 2 PRODUCT DESCRIPTION

---

---

### 2.1 DESCRIPTION OF INSTRUMENT SPECIALITY:

**OMEGA ENGINEERING.** pH / ORP transmitters are used to measure pH or ORP and temperature value.

**This transmitter has many user-friendly and safety features which include:**

- Menu-driven programs that are easy to set-up.
- IP65 enclosure.
- Built-in memory backup to ensure that setup parameter and calibration information are not erased if power is lost.
- Can separately set process temperature (TST1) and Calibration temperature (TST2) manually. If the temperature sensor fails, under automatic temperature compensation mode, instrument will automatically switch to process temperature (TST1) of manual temperature compensation to compensate.
- pH measured value can make offset adjustment (adjusting scope  $\pm 2\text{PH}$ ) so that users can calibrate online.
- Various choice of electric current output. 0/4-20mA Output range can be user programmed.
- Two sets of relay contacts, users can choose high-low meta control independently.
- Separately adjustable high and low set point hysteresis (dead bands) prevent oscillating of relays around the set points.
- Large dual display LCD for easy reading with clear multiple annunciators, alarm status and operational message annunciators.
- Can set calibration time. Instrument will automatically appear “CAL” at regular time to call person to alert that a calibration is needed.
- Glass electrode and Metal antimony electrode can be chosen and be used under different industrial situations.
- During calibrating and setting, hold function freezes output current (0/4 20ma) and releases control relays.
- Ultraviolet rays resistant, LCE of blue back light (LCD=liquid crystal display)
- RS-485. Maximum 100 instruments can be connected.

---

## 2.2 MEASUREMENT AND CONTROL SYSTEM

Typical measurement system includes:

**pH/ORP** on-line transmitter

Integral or separated temperature sensor (**Pt1000**).

Suitable **pH/ORP** measurement electric cable.

Immersion, flow or processing parts with or without grounding electrode.

Terminating controlling parts, eg. Pump or valve.

**0/4-20mA** can connect with recording instrument/data logger.

**RS485** can be used for multi-instrument communication.

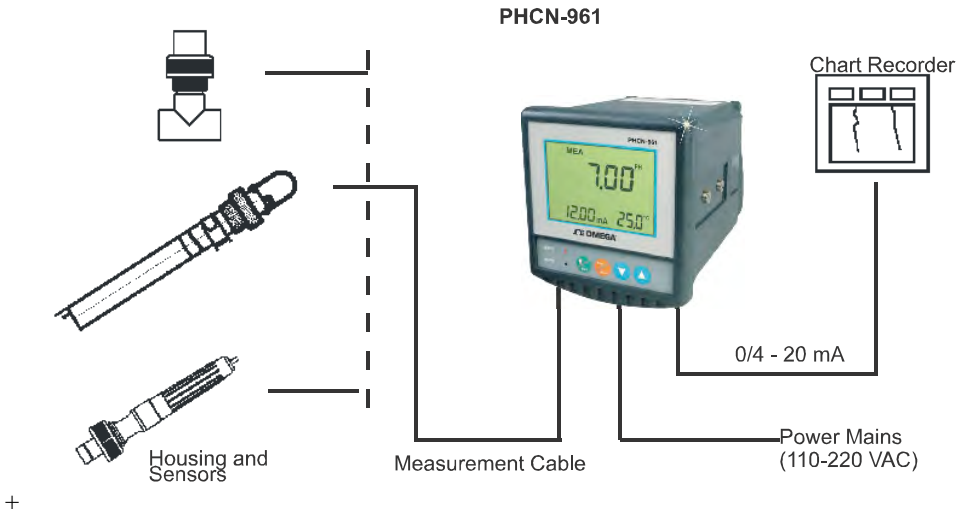

## 2.3 APPEARANCE

### PHCN-961 panel installation



---

### 2.3.1 INTRODUCTION OF DISPLAY

Two liquid crystal regions show measured value and indication and parameters of various status.

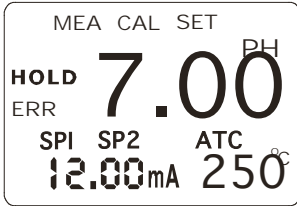



#### Mode Indication\_

- **MEA** : measurement mode
- **SET** : set-up mode
- **CAL** : calibration mode

#### Status Indication:

- **HOLD** : relay actions and electric current output are hold.
- **A T C** : automatic temperature compensation indication, manual temperature compensation is not displayed.
- **ERR** : error or warning indication

### 2.3.2 KEY INSTRUCTION

KEY	Description
	Mode switch key or quit key
	Confirm key Entering sub-function form of function group in setting mode Confirm setting parameter and value Starting calibrating in calibration mode Back light on and off switch in measurement mode
	Choose function group in setting mode Set parameter and value Hold down to change values quickly

### 2.3.3 LED Induction

Relay Induction

**SP1\SP2 LED** show relevant working status of relays.

**SP1\SP2LED** light-on shows that relays are on.

### 2.3.4 Password

When entering calibration mode and setting mode, there are passwords. Passwords are set by factory and users can not modify them by themselves.

Password	Mode / Instruction
028	Calibration Mode
058	Set-up Mode

### 2.3.5 PREVIEW OF FUNCTION

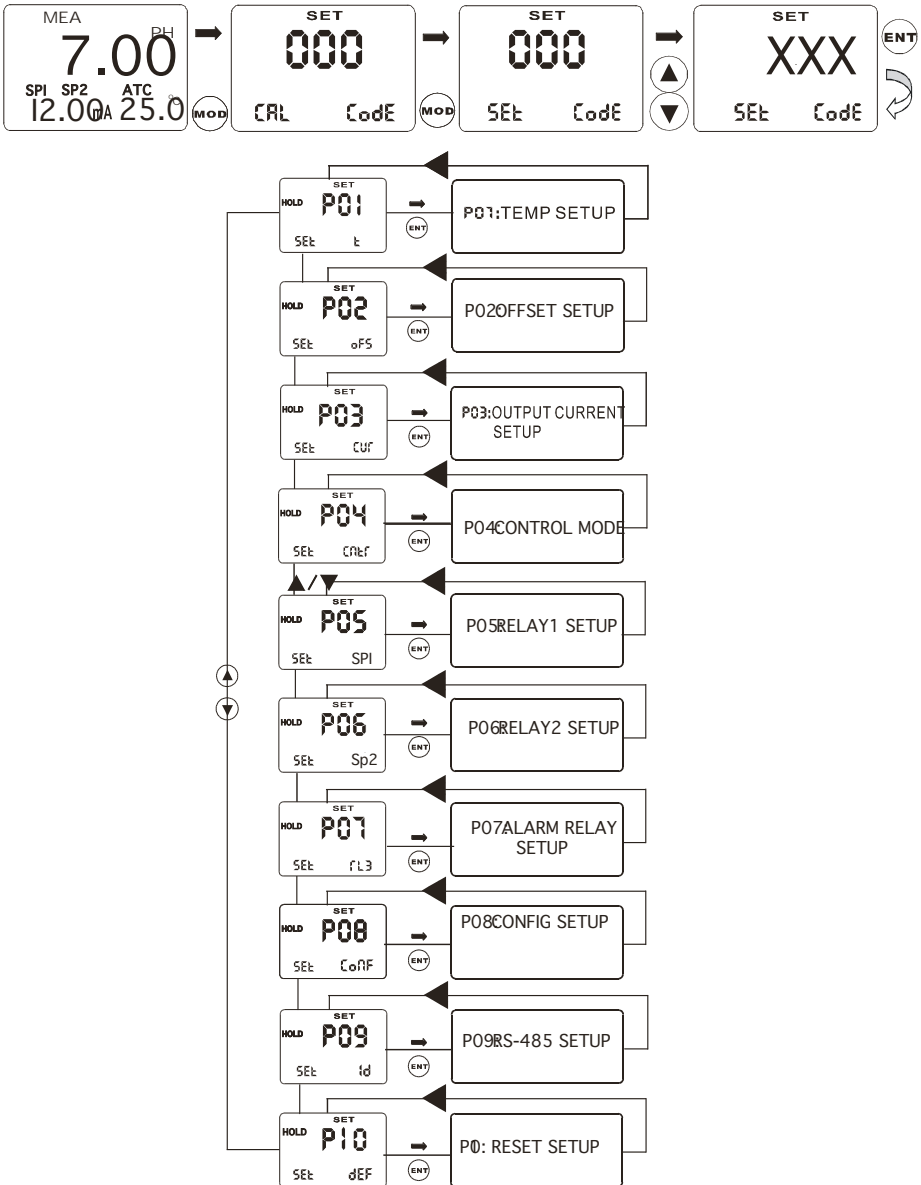

---

---

## 3 INSTALLATION AND ACCESSORY

---

---

### INSTALLATION

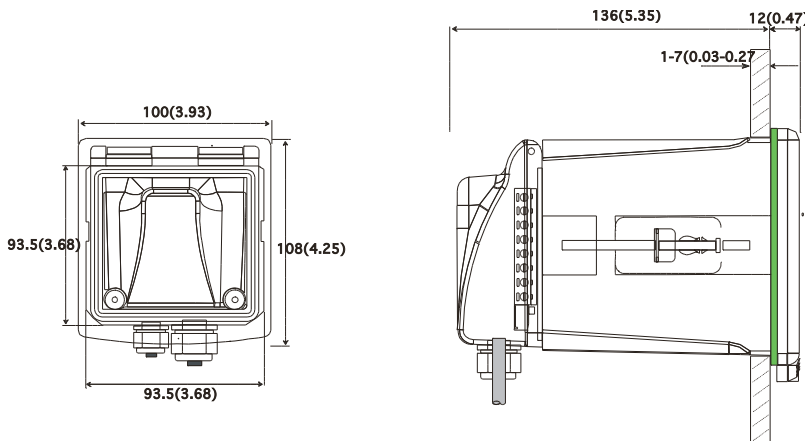

Panel cutout:93.5 \* 93.5mm

**(panel installation)**

## PHCN-961 connection diagram



Warning : Make sure to power off before connecting. The back panel consists of three connectors.

PHCN-961 series connection diagram

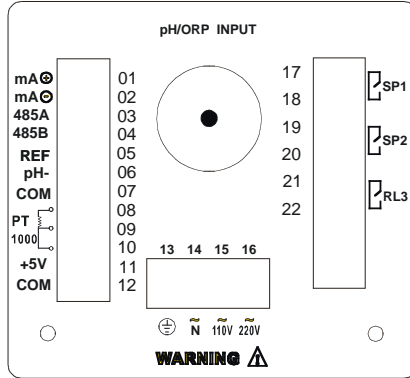

## NEW VERSION

NEW VERSION	
1. pH value 4—20mA output, positive terminal	14. Alternating connect earth wire
2. pH value 4—20mA output, negative terminal	15. Electric source input 110V alternating current
3. 485A output	16. Electric source input 220V alternating current
4. 485B output	17. Relay A (SP1)
5. Y Connector REF terminal	18. Relay A (SP1)
6. <b>Short circuit with 7 under normal status</b>	19. Relay B (SP2)
7. COM, open circuit with 6 pin and connect PMP sensor when display value unstable	20. Relay B (SP2)
8. Temperature electrode positive terminal (PT1000)	21. Clearing Relay (RL3)
9. Temperature electrode negative terminal (PT1000)	22. Clearing Relay (RL3)
10. Temperature electrode sensing terminal (2-wire system, use short circuit between 8 and 9)	 H/ORP input terminal
11. +5V	
12. COM	
13. Connect bigger earth wire	

NOTE: Short circuit with 6 and 7 pin under normal status. Open circuit with 6 and 7 pin, and connect PMP sensor when display value unstable.



## MEASUREMENT MODE

When the controller is initially powered on, it automatically enters into the Measurement mode after the large dual LCD displays all segments briefly.



**Please notice:** in order to get exact measurement information, users should calibrate measurement system (transmitter and electrode).

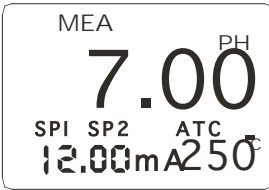

MEA at the top of the LCD shows that the instrument is under the status of measuring. The upper display shows pH or ORP value, while the lower display shows temperature value under pH measurement mode or ORP under ORP measurement mode. Annunciator at the left lower side of the display shows the value of transmitting output electric circuit, which as the way that users can calibrate the output electric circuit.

Such annunciators or icons, as pH, mV, %, at the right side of the display show the current different measurement mode of transmitters.

In measurement mode, you can press  key once or twice to enter into the function form of calibration or set password input.

Then input relevant password to enter into calibration mode or set up mode. Please refer to Item 3(Calibration Mode) or Item 4 (set up mode).

Press  key under measurement mode, you can open or close back light of LCD.

## 4 CALIBRATION MODE

You can press  once under measurement mode and then input password 28 to get access to calibration mode. Please operate according to following:

### 4.1 ENTERING CALIBRATION MODE

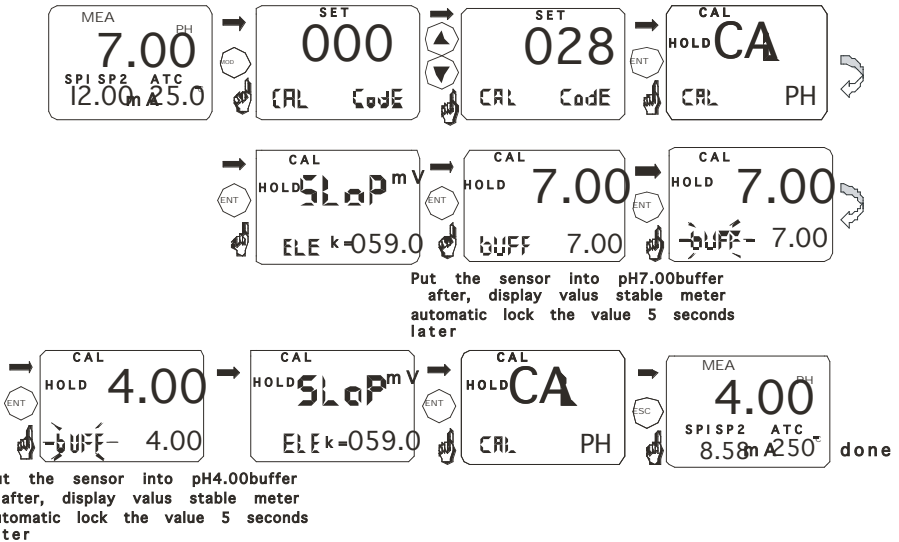

1. Press  once under measurement mode to enter into function form for password input of calibration mode.

2. After entering function form of calibration password input, LCD will ask you to input password. Press ▲ or ▼ to input calibration password **28**, then press **ENTER** to confirm the password.

3. Press **ENTER** to enter into calibration sub function form, if instrument is set up as pH measurement mode, lower display will show CAL pH. If instrument is set up as ORP measurement mode, lower display will show CAL ORP. If you want to calibrate. (please refer to upper pictures).





**NOTE** : Anytime press  to quit calibration mode and return to upper function. If returning to measurement mode, old calibration information will be kept and used. After returning to measurement mode, password will automatically set up form **28** to **000** when entering calibration mode.

## 4.2 pH CALIBRATION



This instrument can conduct one point or two points calibration in pre-set standard buffer liquid. The value of standard buffer solution is based on 25°C.

1. Entering calibration mode as Item 4.1 described. LCD will show CAL pH. (pH Calibration mode).



**Note** : If LCD shows **CAL ORP**, please switch pH and ORP measurement mode according to the procedures of Item 5.8.

2. Press  key to enter into calibration, LCD will show slope and function form. The lower display will show ELE K=59.2, this function form shows the slope of last calibration. The upper display will show CAL and the main display zone will show SLOP. Press  key to enter into calibration procedures, LCD main display zone will show actual measured value, the right lower display will show the value of standard solution which should be calibrated.



3. Put electrode into the first standard buffer solution. You should put temperature electrode into the same solution under the automatic temperature compensation mode. As the same, you should put liquid earth wire electrode into the solution at the same time in balanced input mode.







4. You can select one point calibration or two point calibration: Press  key to calibrate at **6.86 or 7.00pH**. The lower display shows **BUFF 6.86(7.00)** to tell user the standard solution value. **BUFF** will blink when calibrating. During calibrating process, instrument will automatically distinguish signals which electrode input. If the signal input in required time is stable and in the slope range, the instrument will accept the calibration, it will record and modify the zero point information of the electrode. The lower display will show BUFF 1.68 to tell the standard solution value the second point of calibration. Users can press  or  key to select relevant calibration solution. ➔**USA 1.68>4.01>10.01>12.45\_(NST 1.68>4.01>9.18>12.45)**.

---

Press  twice to quit one-point calibration and return to measuring status. Press  to continue next point calibration.

Take electrode out of the first standard solution, clean it and put it into the second standard solution.



5. If one point calibration is selected, instrument will show the slope, but zero point adopts new calibration value while the slope remains the value of last calibration. If select two point calibration, the lower display will show the next value of standard buffer solution. Use  or  key to selects the second standard buffer solution from the pre-set standard buffer solution. Take electrode out of the first standard solution, clean it and put it into the second standard solution. Press  key, **BUFF** will blink. Instrument will modify the indication to the value of standard solution.
6. After finishing the second calibration in standard buffer solution, instrument will automatically show SLOP on LCD main display zone. The right lower display shows the slope of electrode. Parameter of zero point and slope will be renewed after each calibration.

	<p><b>NOTE:</b> Press  key to quit set up mode at any time. Instrument will return to measurement mode automatically.</p>
	<p><b>NOTE:</b> Transmitter will show <b>ERR</b> when calibration is in error. Under this situation, press  to quit and calibrate again from step 1. It will show ERR again under following situations:</p> <ol style="list-style-type: none"> <li>(1) Use wrong standard solution or standard solution is expired.</li> <li>(2) Electrode is aging or not clean or broken.</li> <li>(3) Electrode wire is broken or joint corrosion has occurred.</li> </ol>
	<p><b>NOTE:</b> When calibrating under manual temperature compensation, transmitter will automatically switch to calibration temperature from pre-set measurement temperature. When leaving calibration mode, transmitter will switch to measurement temperature again. (Please refer to Item 5.2 for setting measurement temperature and calibration temperature)</p>
	<p><b>NOTE: ELE K=59.1 presents the conversation coefficient 59.1mV/pH of pH electrode, which means each pH is converted by 59.1mV electric potential.</b></p> <p><b>For example: when slope is 90%, the conversation coefficient is <math>59.1 * 90\% = 53.19</math>.</b></p> <p><b>When the conversation coefficient is lower than 45mV, which is equal to 75%, users should change electrode. Instrument will show ERR automatically when the conversation coefficient is lower than 40mV, which is equal to 67% slope.</b></p>

### 4.3 ORP CALIBRATION

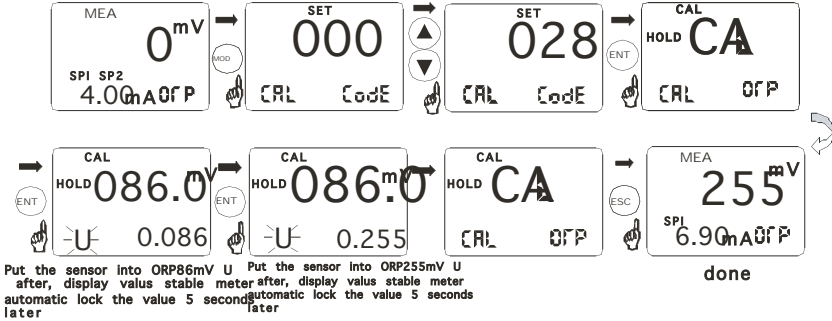
If transmitter is set up as ORP measurement mode. You can only calibrate one point.



1. Entering calibration mode described as Item 4.1. LCD will show CAL ORP.  
NOTE: If LCD shows CAL pH. Please switch to ORP mode from pH mode according to procedures of Item 5.8.
2. Put ORP electrode into ORP standard solution (86mV).
3. Press  key to begin calibrating. mV value displayed is the mV value output by ORP electrode. There is no offset value. The lower display will show U and blink. If one point calibration is finished, Then, the lower display shows 255mv to tell user to change standard solution.
4. Clean electrode and put it into relevant standard solution. Press  key to confirm. Instrument enters into calibration mode. After calibrating, instrument automatically returns to slope display function form. Press  to return to measurement mode and finish calibration process.

---

---

## 5 SET UP MODE

---



---

### ENTERING SET UP MODE

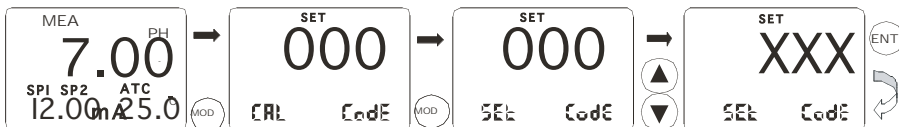
In set up mode, transmitter can be set up according to your need.



1. Press  twice in measurement mode.

2. LCD will ask you to input password. Use  or  to input the password.

– Input XXX to change parameter.



3. Press  to confirm.





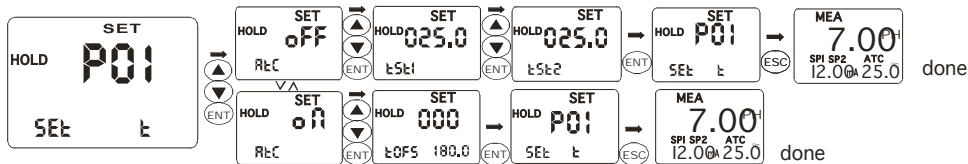











**NOTE:** Press  twice to quit set up mode at anytime. Instrument will return to measurement mode automatically.

## 5.1 P01: TEMPERATURE SET-UP SUB-FUNCTION



1. Press  to enter from P01 screen. LCD main display zone shows ON, which means automatic temperature compensation function, is on. User can press  or  to switch to OFF and stop automatic temperature compensation function.

2. Press  when automatic temperature compensation function is on, instrument enters into modifying status of temperature measurement value. LCD main display zone show current measurement value of temperature. The lower display TOFS tell users that they can use  or  to modify current temperature display value. Press  to confirm and return to P01 Sub-function form. Use  or  to select other sub functions or press  to return to measurement status.

3. In the status of manual temperature compensation, press  and instrument enter set up status of manual temperature compensation user can use  or  to set up process temperature TST1 and calibration temperature TST2. Press  to confirm and return to P01 Sub-function form or press  or  to select other sub functions to set up or press  to return to measurement status. TST1 is the compensation temperature under normal measurement while TST2 is the compensation temperature under calibration. Since temperatures are not the same in calibration and normal measurement when instrument is used, two set up values under manual temperature compensation status are convenient. Users should not set manual temperature compensation value back and forth. For example, if user's process temperature is  $50.0^{\circ}\text{C}$  and the temperature of standard solution when calibrating is  $10.0^{\circ}\text{C}$ , user can set TST1 as  $50.0^{\circ}\text{C}$  and set TST2 as  $10.0^{\circ}\text{C}$  for convenient use.



## 5.2 P02: OFFSET SET-UP SUB-FUNCTION

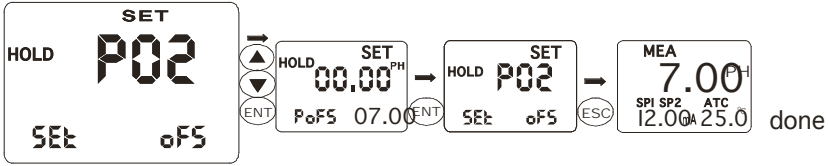

1. In P02 sub-function form, Press . LCD main display zone shows **pH** actually measured value in **pH** measurement mode. The lower display shows **POFS**. The right lower display show offset. LCD main display zone shows ORP actually measured value in ORP measurement mode. The lower display shows UOFS. The right lower display show offset.









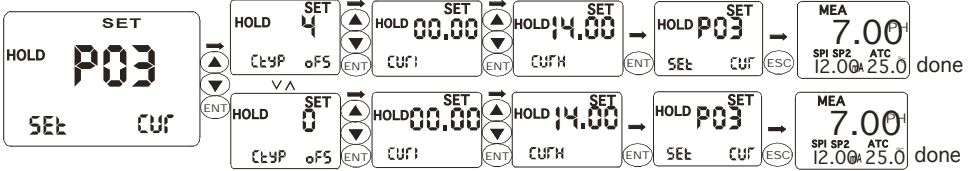





2. User can press or to adjust offset to modify measurement value. Press to confirm and return to P02 sub-function form. Use or to select other sub-function to set up.



Note: Press to quit set-up mode at anytime. Instrument will return to measurement mode automatically.







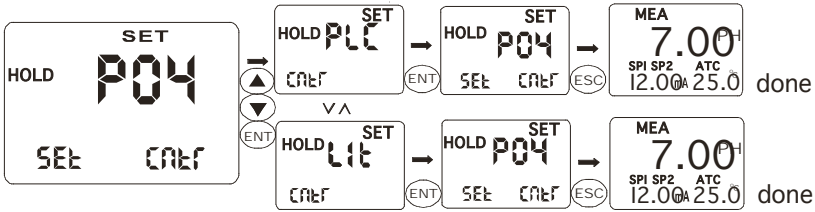

### 5.3 P03: OUTPUT ELECTRIC CIRCUIT (SP1/SP2) SUB-FUNCTION



<p>1. Press  to confirm in P03 sub-function. Entering set up of the sub-function.</p>	
<p>2. The lower display shows CTYP. The upper display shows 4 (it means electric circuit output from 4 m A to 20 m A). User can press  or  select 0 (it means electric circuit output from 0 to 20 m A). Press  to confirm and enter into set-up of transmitting range.</p>	
<p>3. The lower display shows CURL while the upper display shows 0.00, which means that 0.00mA transmitting range indicates 0.00pH. User can press  or  to adjust the actual value. Press  to confirm. The lower display shows CURH while the upper display shows 14.00, which means 20.00mA transmitting range indicates 14.00pH. User can press  or  key to adjust the actual value. Press  to confirm and return to P03 sub-function firm. Use  or  to select other sub-functions and to set up.</p>	
<p>For example, set CTYP to 0 or 4, set CURL to 2.00 and set CURH to 10.00, which means 0 or 4 to 20mA output mode is selected as circuit output. 0/4.00mA indicates 2.00pH, 20.00mA indicates 10.00pH .</p>	
	<p>Note: Press  to quit set-up mode at anytime. Instrument will return to measurement mode automatically.</p>
	<p>Note: This parameter allows you to set range of circuit output, but transmitting high point and low point can't be overlapped.</p>

## 5.4 P04: CONTROL MODE SUB-FUNCTION



1. Press  in P04 sub-function form to enter into set up procedure.
  2. The lower display shows CNTR while the upper display shows LIT. (The control mode of instrument is under limited control mode). User can press  or  to select PLC mode (The control mode of instrument is under proportion control mode). Press  to confirm and return to P03 sub-function form. Use  or  to select other sub-functions and to set up.
-  **Note:** Press  to quit set up mode at any time. Instrument will return to measurement mode automatically.

## 5.5 P05: RELAY 1 SET-UP SUB-FUNCTION

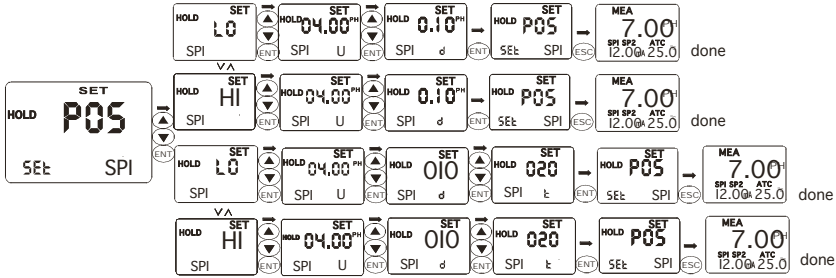

1. In P05 sub-function form. Press to enter into set-up procedure.

2. The lower display shows SPI while the upper display shows HI, which means set point 1 is under high-point control status. (If instrument control made is set up to LIT limited point control mode, relay begins to work when the measured value up to set value. If instrument control mode is set up to PLC proportion control mode, measured value must be raised to approach set value). Press to confirm and enter into next set up procedure.

3. The lower display shows SPI U while the upper display shows value. User of the function form can press or to adjust the value to confirm set up value. Press to confirm and enter into next set up procedure.

4. This function form sets hysteresis band under limited control mode to protect relay, which may oscillate frequently around set point and be damaged. Controlling proportion range is set up under proportion control mode (this parameter is not lower than 5 under PLC mode) to confirm and adjust time period of adding chemical automatically. Press to confirm and enter into next set up procedure. Under proportion control mode, this function form is used to set time period of whole controlling circle. Press to confirm and return to P05 sub-function form. USE or select other sub-function and to set up.



Note: Press to quit set up mode at any time.

Instrument will return to measurement mode automatically.

## 5.6 P06: RELAY 2 SET-UP SUB-FUNCTION

Working principle of this part is the same as which of P05 relay 1 set-up sub-function. Please operate according to P05.

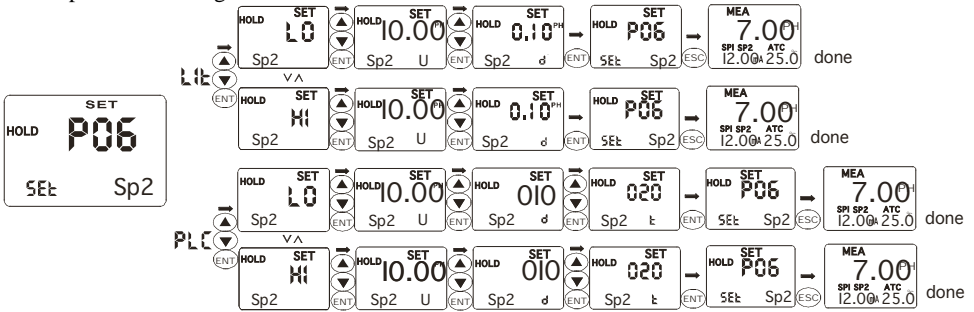

**NOTE:** Set-up value range of hysteresis band under limited control mode is from 0.00–2.00pH. For example, if high point is 7.00pH and hysteresis band is 0.50pH, movement range of the relay is from 6.50pH to 7.00pH. If low point is 6.00pH and hysteresis band is 0.20pH, movement range of the relay is from 6.00pH to 6.20pH.

**NOTE:** In PLC control mode, movements of the relay meet following formulas:

$$C * (VM - VS) * U * T / 14$$

**C** is discriminate parameter for high / low point.

It is -1 when set to high point and it is 1 when set to low point.

**VM** is measured value.

**VS** is set value.

**U** is control parameter.

**T** is time constant (represent the whole movement circle of relay)

For example, set high point is 7.00pH, actual measured value is 6.50pH, control parameter is 10, time constant is 10 seconds.

$$-1 * (6.50 - 7.00) * 10 * 10 / 14 = 3.57 \text{ second}$$

According to the above formula, pick-up time of relay is 3.6 second and release time is 6.4 seconds.

If the result of above formula is negative, relay won't move. If the result is move than T, relay keeps picking up until the result is less than T.

## 5.7 P07: ALARM RELAY 3 SET-UP SUB-FUNCTION

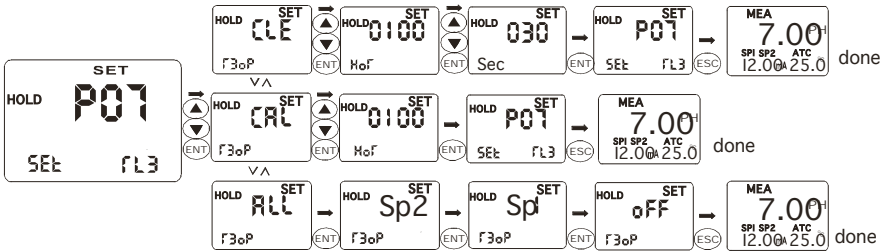

1. Select P07 sub function, Press to confirm. Enter into set-up procedure.

2. Select working mode. Press or to select suitable control mode.

- **cLE**=relay 3 as cleaning control relay
- **cAL**=relay 3 as calibrating indication relay
- **ALL**=move with two relays simultaneously
- **SP 1**=relay 3 moves with SP1 (limited control mode only)
- **SP2**=relay 3 moves with SP2 (limited control mode only)
- **oFF** =relay 3 is off

Press **ENTER** to confirm your set up.

If user select CAL working mode, he can set calibration indicate intervals in the function form, use hour as the unit. In this way, instrument and electrode can keep their reliability.

If user select CLE working mode, he can set cleaning time intervals in the function form, use hour as the unit; cleaning continuous time, use second as the unit. In this way, instrument and electrode can keep their reliability. User can install cleaning equipment to increase service life and reliability of electrode.

3. Press to confirm and return to P07 sub-function form. Use or to select other sub-functions to set up.







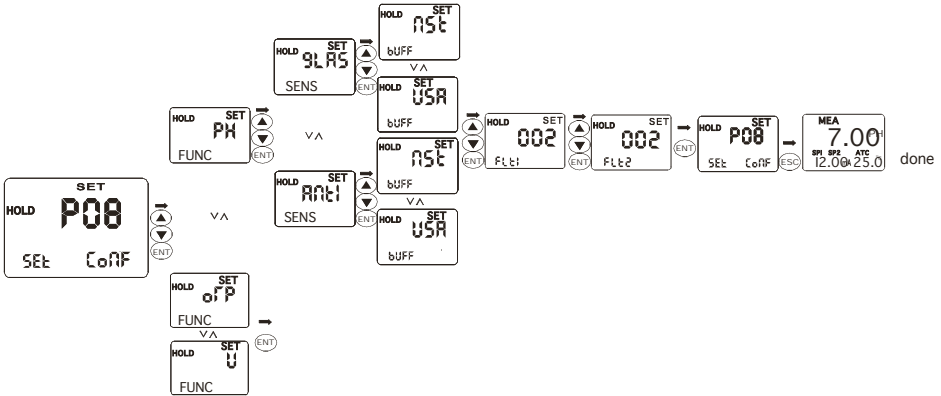











NOTE: Press to quit set up mode at any time. Instrument will return to measurement mode automatically.

## 5.8 P08: pH/ORP function AND SENSOR CONFIGURATION sub-function



1. In P08, Press  to confirm and enter into set up procedure.

2. Press  to confirm. If you select ORP or voltage measurement mode, after  to confirm, instrument will return to P08 sub-function form. If you select pH measurement mode, instrument will enter electrode-select function form automatically. The lower display shows SENS, and main display zone. Shows electrode kind, glass electrode or antimony electrode. User can use  or  to select the electrode kind he need. Then, press  to confirm and enter into select items for standard solution. The lower display shows BUFF while the upper display shows NST (Nist standard) or USA (USA standard). User can use  or  to select items according to kind of standard solution, press the  to confirm. The next is the Temperature Filter (Filter 1), press the  or  key to set the number, then press the  to confirm, and then that will enter the pH/ORP Filter (Filter 2). Press the  or  key to set the number and press the  to confirm. Press  to confirm and return to P08 sub-function form. Use  or  select other sub functions to set up.







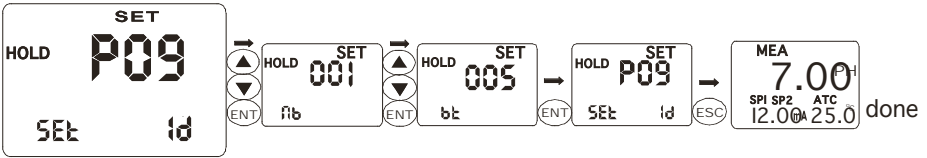



**NOTE:** Press  to quit set-up mode at any time. Instrument will return to measurement mode automatically.

## 5.9 P09: transmitting rate sub function



1. Press  to confirm in P09 and enter in set-up procedures.

2. The lower display shows **nb** while the upper display shows **001**, which indicates that user is setting communication address **ID NO.** of the instrument, from 001 to 128. Use  or  to select necessary ID and press  to confirm. Then enter into next set up function form.

3. The lower display of the instrument shows **bt** while the upper display shows **005**, which indicates that user is setting communication rate function. Use  or  to select necessary communication rate. Press  to confirm and return to P09 sub-function form. Use  or  to select other sub-function to set up.

4. Corresponding communication rate to codes.

<b>bt</b>	<b>000</b>	<b>001</b>	<b>002</b>	<b>003</b>	<b>004</b>	<b>005</b>	<b>006</b>	<b>007</b>
baud rate	300	600	1200	2400	4800	9600	19200	38400







Note: Press  to quit set-up mode at any time.  
Instrument will return to measurement mode automatically.

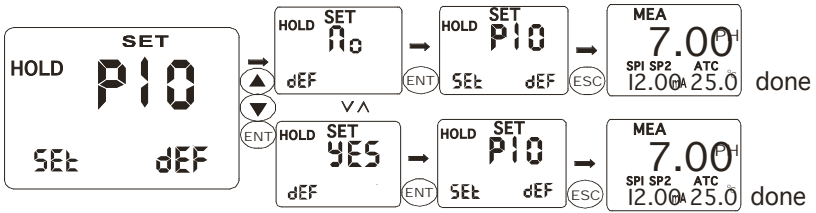

### 5.10 P10: reverting to factory default settings



- |  |   |
|--|---|
| <p>1. Press  in P10 to enter into set-up procedures.</p>  |   |
| <p>2. The lower display of the instrument shows DEF while the upper display shows NO (YES).<br/>         User can press  or  to select necessary items. If select YES, all settings will be reset to factory default. User's setting will be lost.</p> |   |
|   | <p><b>NOTE:</b> Press  to quit set-up mode at any time.<br/>         Instrument will return to measurement mode automatically.</p> |

---

## 5.11 COMMUNICATION PROTOCOL

### 1. Protocol setting

This instrument uses RS-485 communication. It's can be connected with 1 to 64 instruments in 2 wires at the same time and communicate with PC. The distance of communication is around 1200M.

The data form is "N81"(1 start bit, 8 data bits,1 stop bit, NO verify check code)

The baud rate is 300 to 38400 bit/s (usually is 9600 bit/s)

Users have to set the ID(NB) of the instruments and the baud rate(BT) before connecting to RS-485

BT	0	1	2	3	4	5	6	7
Baud rate	300	600	1200	2400	4800	9600	19200	38400

Usually, the instrument is in stand by in receiving status. Once it receives the correct ID then it will send out the data to PC. Finished sending it will enter into receive status again.

To avoid the conflict, each instrument has to use different ID(decided by NB)

All of the instruments and PC must use the same baud rate.(decided by BT)

### 2. Data form

All one-word data is from -32767 to +32767, using the hexadecimal number system, the high bit is sign.

All one-byte is integer.

The data is ASCII code :the start sign is @(40H), the end sign is CR(0DH)

The other data use the ASCII code to express the hexadecimal number system

All data should be between 30H to 39H and 41H to 46H. the instructions are form 51H to 5AH.

Double-byte sending: the low byte is the first, the high byte is the second

One-byte sending: the high nibble is the first, the low nibble is the second.

A full communication form is :40 ,ID, the sequence of the instruction,CRC,0D

The ID is the number of the instrument(NB)

CRC is the Circulation redundant codes verification, it's the ID code and data codes XOR result.

### 3. The communication instructions

- 1\_ RD: read floating data
- 2\_ RE: read the appointment data by start address and bytes (the large byte can not over 28 bytes)
- 3\_ RR: read all of data (8-word, 12-byte), totally 28 bytes.

### 4. Introduce the instructions( the ID is 1)

- 1\_ RD (read the floating data): PC send: 40,30,31,51,44,CRCH,CRCL,0D (8 bytes)
  - 40: start byte
  - 30 31: the ID of instrument (the hexadecimal: 0~3FH, ASCII: 30 30~33 46)
  - 51 44: instruction of R, D
  - CRCH,CRCL: CRC
  - 0D : the end byte

the response by instrument is “40, 30, 31, 52, 44, 30,  
30,V1LH,V1LL,V1HH,V1HL,3X,V2LH,V2LL,V2HH,V2HL,3X,3X,3X,3X,  
3X,CRCH,CRCL,0D”

- 40 : the start byte
  - 30 31 :the ID of instrument
  - 52 44 30 30 : the fixed data
  - V1LH,V1LL, V1HH,V1HL: pH/ORP value
  - 3X: the position of decimal (32:pH mode,2 decimal; 30:ORP/mV mode, no decimal)
  - V2LH, V2LL, V2HH, V2HL : temperature value
  - 3X : the status of relay 1 , 30 :open ;31:close
  - 3X : the status of relay 2 , 30 :open ;31 :close
  - 3X : the status of relay 3, 30 :open; 31:close
  - 3X : ERR status, 30 : correct; 31:error
  - 3X : parameter modify, 30: no modify; 31:modify
  - CRCH,CRCL : CRC
  - 0D : the end byte
- Total : 24 bytes

2) RE (read the appointment data)

The PC send : 40, 30, 31, 52,45, 30, 30, adrH,adrL, lthH, lthL, CRCH, CRCL, 0D (total 14 bytes)

40 : the start byte

30 31 : the ID of instrument (the hexadecimal: 0~3FH, ASCII): 30 30~33 46) :

52 45 : the instruction R, E;

30 30 :reserve

adrH adrL : the address of the start parameter byte(the hexadecimal: 0 ~1BH: ASCII :30 30~31 42) :

lthH lthL : the count of the parameters (the hexadecimal: 1~1CH ; ASCII: 30 31~31 43) :

CRCH CRCL : CRC

0D : the end byte

The adr is the start address(00~1BH),lth is the count of the byte. The table is the relation of the adr and parameter.

adr	00	01	02	03	04	05	06	07	08	09	0A	0B	0C	0D
para	TS11	TS11	TS12	TS12	SPTU	SPTU	SP2U	SP2U	CURL	CURL	CURH	CURH	POFS	POFS
adr	0E	0F	10	11	12	13	14	15	16	17	18	19	1A	1B
para	HOR	HOR	AAA	FUNC	R3OP	TOFS	SEC	SP1D	SP11	SP2D	SP21	NB	BT	CONF

If adr>1BH or adr+lth>1BH, the return the error code: 40,30,31,52,45,2A,2A,CRCH,CRCL,0D

The 2A 2A is the error sign

If the address range is correct then the instrument will send back data :

40,30,31,52,45,D1,D2,D3,.....Dn,CRCH,CRCL,0D

40:the start byte

30 31 : the ID

52 45 : the fix data

D1~Dn : parameters from instrument to PC

CRCH : CRCL:CRC

0D : the end byte

3) RR (read all of parameters) the PC send : 40,30,31,52,52,CRCH,CRCL,0D(8 bytes)

40: the start byte

30 31 : the ID

52 52 : the instruction of R, R

CRCH,CRCL :CRC

0D : the end byte

The instrument response : 40,30,31,52,52,D1\_D2,.....,D55\_D56,CRCH,CRCL,0D(64 bytes)

40 : the start byte

30 31:ID

52 52 : the fix data

D1\_D56\_the parameter of sending (8 double byte,12 byte, total 28 bytes)

CRCH\_CRCL: CRC

0D: the end byte

#### 4. Notice for programming the communication program

If the instrument receives the data with the start byte is 40 and the count of sequence data over 16 bytes and did not find the 0D then the data is invalid. The instrument will not respond.

If the sequence data is not between 00H to 0FH, the sequence data is invalid. The instrument will not respond. But the other errors, ex: the wrong instruction, the wrong address, the wrong parameter counts, the wrong CRC and so on, the instrument will respond the wrong information.

All parameters, please see the following table, some parameters are include decimal.

para	TST1	TST2	SP1U	SP2U	CUR L	CUR H	POFS	HOR	AAA	FUN C
decima	1	1	0/2	0/2	0/2	0/2	0/2	0	0	0
para	R3OP	TOFS	SEC	SP1D	SP1T	SP2D	SP2T	NB	BT	CON
decima	0	1	0	0/2	0	0/2	0	0	0	0

The PC display the reading values should be include the decimal.

TOFS is the correct value of temperature, the setting range is 0~200, the display range is -100~100, so the PC should be subtract 100 and display with sign.

1) FUNC is the display mode of instrument : 0=mV; 1=ORP; 2=pH

2) R3OP is the mode of relay 3: 0=NOR ; 1=SP1; 2=SP2 ; 3=ALL ; 4=CAL ; 5~CLE

3) AAA is the reserve parameters

4) CONF is a byte parameter, the define is following,

Bit 7 : temperature compensation : 1=automation 2>manual

Bit 6: current output, 1=4\_20mA ; 0=0~20mA ;

Bit 5: SP1 , 1=HI ; 0=LO ;

Bit 4: SP2 , 1=HI ; 0=LO ;

Bit 3 : control mode , 1=PLC ; 0=Lit ;

Bit 2 : electrode selection , 1=ANTI ; 0=GLAS ;

Bit 1: buffer, 1=NST ; 0=USA;

Bit 0 :reserve

## 6 TECHNICAL PARAMETERS

### 6.1 TECHNICAL PARAMETERS FORM

<b>PHCN-961 Transmitter / Controller</b>	
pH Range	-2.00 to 16.00 pH
Analytical degree & precision	0.01 pH and $\pm 0.01$ pH
mV Range	-1999 to 1999 mV
Analytical degree & precision	1 mV / $\pm 1$ mV
Temperature	-9.9 to 130 °C
Analytical degree & precision	0.1 & $\pm 0.5$ °C
Temperature electrode	Pt 1000
Temperature compensation	Automatic ( $\pm 10$ °C offset adjustment) / manual
<b>Set point and control function</b>	
Control function	Limited point / proportion ( pulse length )
Cleaning circle	From 1 to 999 hours
Cleaning time	From 1 to 999 seconds
Control hysteresis band	0.01 to 2 pH
ORP hysteresis band	1 to 200 mV
Relay output	Three SPST relays 250V1A
<b>Communication</b>	
<b>RS-485</b>	<b>client program</b>
<b>Electric current information and connection</b>	
Electric source	110 or 220 V AC / 60 or 50 Hz
Signal output / load	0/4 – 20 mA isolated current output
Signal output load	600 $\Omega$
pH / ORP input	BNC (10 <sup>13</sup> impedance)
Connection terminal	Removable plug-in unit
Main fuse wire	250 mA, anti-surge
<b>Alarm function</b>	
Function ( switch able )	Close
<b>Display</b>	
LCD( liquid crystal display)	Big-size screen of crystal display, blue back light
<b>EMC Specification</b>	
Electromagnetic emission	EN 50081-1
Electromagnetic induction	EN 50082-1
<b>Environmental conditions</b>	
Working temperature	-10 to 50 °C (14 to 122 °F)
Humidity	10 to 95% (no frozen dew)
Protection grade	NEMA 4X, IP 65

## 6.2 PARAMETER SETTING AND FACTORY PRELIMINARY VALUE

NO.	Indication	Parameter Name	Symbol	Contents	Remark	Valid range	Factor y value
01		LOCK	LOC	Password for entering function		0~200	0
02	P1	ATC	AiC	Auto temperature compensation		ON/OFF	OFF
03	TC	TSET1	tSt1	Temperature set up of manual	Only valid for manual	-10.0~100.0°C	25.0
04		TSET2	tSt2	Calibration temperature set up		0.0~60.0°C	25.0
05		TOFS	tOfS	Temperature measurement offset	Only valid for manual	-10.0~10.0°C	0.0
06	P2	POFS	POFS	PH value measurement offset	Only valid for PH mode	-2.00~2.00PH	0.00
	OFS	VOFS	VOFS	mV value measurement offset	Only valid for ORP mode	-200~200mV	0
07	P3	CTYP	CtyP	Type of current output		0/4 ~20mA	4
08	CUr	CURL	CUrL	Low limit of transmitting output	PH mode: 0.01PH unit	-1999~1999	0
09		CURH	CUrH	High limit of transmitting output	ORP mode: 1mV unit	-1999~1999	1400
10	P4Cntr	CNTR	Cntr	Control way of relay 1, 2		PLC/ Lit	Lit
11	P5	SP1	SP1	Way set up of relay 1		HI / LO	LO
12	SP1	SP1U	SP1U	Setting value of relay 1	PH mode: 0.01PH unit	-1999~1999	400
13		SP1D	SP1d	Relay 1 hysteresis / proportion	ORP mode: 1mV unit	0~200 (2.00)	10
14		SP1T	SP1t	Relay 1 circle (second)	Only valid for PLC	0~200 seconds	20
15	P6	SP2	SP2	Way set up of relay 2		HI / LO	HI
16	SP2	SP2U	SP2U	Setting value of relay 2	PH mode: 0.01PH unit	-1999~1999	1000
17		SP2D	SP2d	Relay 2hysteresis / proportion	ORP mode: 1mV unit	0~200 (2.00)	10
18		SP2T	SP2t	Relay 1 circle (second)	Only valid for PLC	0~200 seconds	20
19	P7 rL3	R3OP	r3OP	Working mode of relay 3		OFF/SP1/SP2/ ALL/CAL/CLE	CAL
20		INT	HO <sub>r</sub>	Interval (hour)	valid for calibration and cleaning mode	0-999	100
21		DUR	SEC	Operating time (second)	valid for cleaning mode	0-200	30
22	P8	FUNC	FUnC	PH / ORP/mV select		PH/ORP/mV	PH
23	CONF	SENS	SenS	Antimony / glass electrode select	Only valid for PH mode	Anti/GLAS	GLAS
24		BUFF	buFF	USA/nST standard select		NST/USA	USA
25	P9	NB	nb	Set ID number for 485		0-63	1
26	ID	BT	bt	Communication rate		0-7	5
27	P10 DEF	DEF	dEF	Reverting to factory default setting	Reset to factory default parameter.	YES/NO	NO

---

## APPENCLIX 2 – pH TEMPERATURE CORRESPONDING TO pH BUFFER SOLUTION

Following form shows standard pH value of pH standard buffer solution under different temperature

Temperature (°C)	pH 1.00	pH 4.01	pH 6.86	pH 7.00	pH 9.00	pH 9.18	pH 10.01
0	0.96	4.01	6.98	7.12	9.33	9.47	10.32
5	0.99	4.01	6.95	7.09	9.24	9.38	10.25
10	0.99	4.00	6.92	7.06	9.16	9.32	10.18
15	0.99	4.00	6.90	7.04	9.11	9.27	10.12
20	1.00	4.00	6.88	7.02	9.05	9.22	10.06
25	1.01	4.01	6.86	7.00	9.00	9.18	10.01
30	1.01	4.01	6.85	6.99	8.95	9.14	9.97
35	1.01	4.02	6.84	6.98	8.91	9.10	9.93
40	1.01	4.03	6.84	6.97	8.88	9.07	9.89
45	1.01	4.04	6.83	6.97	8.85	9.04	9.86
50	1.01	4.06	6.83	6.97	8.82	9.01	9.83
55	1.01	4.08	6.83	6.97	8.79	8.99	9.81
60	1.02	4.10	6.84	6.98	8.76	8.96	9.79
70	1.02	4.12	6.85	6.99	8.72	8.92	9.76
80	1.02	4.16	6.86	7.00	8.68	8.89	9.74
90	1.02	4.20	6.88	7.02	8.65	8.85	9.73



### Appendix 3 – hysteresis band

#### Simple Explanation on the Function of Hysteresis Band

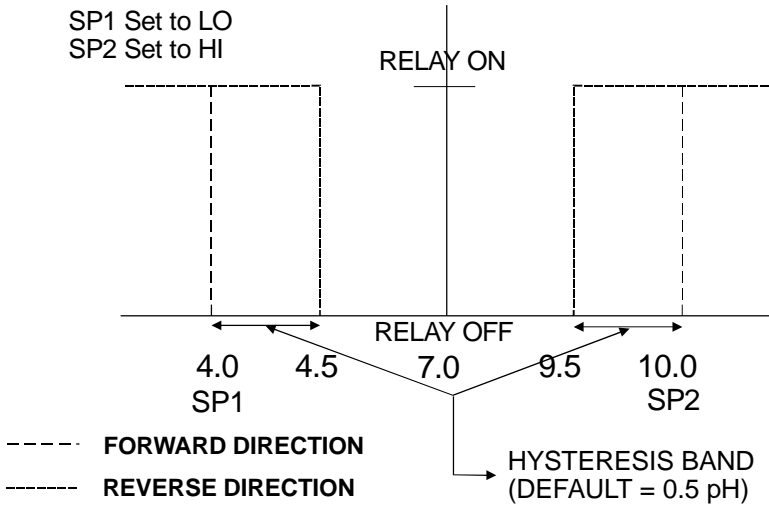

The controller relay activates when the set-point is reached. In the reverse direction, it closes. Relay continues to be active till the value reaches the amount set by hysteresis band.

---

## APPENCLIX 4 – CONTROL MOVEMENT

### General Instructions Concerning Controller Setting

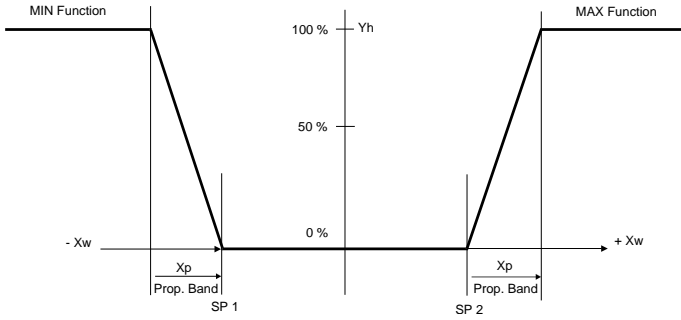

Control characteristic of P-Controller as proportional controller

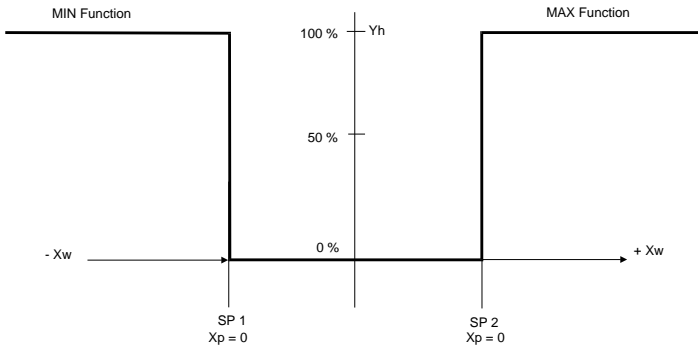

Control characteristic of P-Controllers as limit value switch

## Control signal of pulse length control

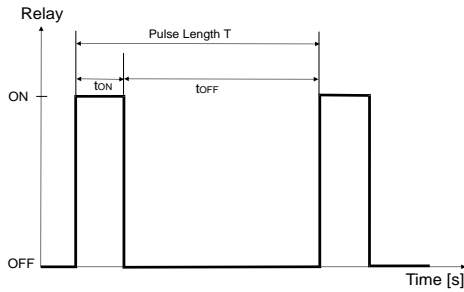

### Control signal and pulse length control

Out put of relay controlled by hysteresis band is time. Crile T for open or close is constant. Different value comes from limited value, increase or decrease of open time is in accordance with proportion range.

#### Following applications\_

$$t_{ON} + t_{OFF} = T \text{ (Const.)}$$

greater divergence → greater  $t_{ON}$

$X_p$  exceeded →  $t_{ON} = T$  (relay remains picked up)

---

## ACCESSORY 5 – ABBREVIATIONS IN FUNCTION FORM

<i>Character</i>	<i>Meaning</i>
MEA	Measurement mode
CAL	Calibration mode
ENT	Confirm
OFS	Zero point offset
SET	Set up
ATC	Automatic temperature cor
SP1	Set point 1
SP2	Set point 2
LO	Low limit
HI	High limit
CNtr	Control
LIt	Limited point control
PLC	Pulse length control
RL3	Relay
OUT	Output signal
CONF	Configuration
CLE	Clean
GLAS	Glass electrode
ANTI	Antimony electrode
DEF	Default
CUR	Output electric circuit 1

## WARRANTY/DISCLAIMER

OMEGA ENGINEERING, INC. warrants this unit to be free of defects in materials and workmanship for a period of **13 months** from date of purchase. OMEGA's WARRANTY adds an additional one (1) month grace period to the normal **one (1) year product warranty** to cover handling and shipping time. This ensures that OMEGA's customers receive maximum coverage on each product.

If the unit malfunctions, it must be returned to the factory for evaluation. OMEGA's Customer Service Department will issue an Authorized Return (AR) number immediately upon phone or written request. Upon examination by OMEGA, if the unit is found to be defective, it will be repaired or replaced at no charge. OMEGA's WARRANTY does not apply to defects resulting from any action of the purchaser, including but not limited to mishandling, improper interfacing, operation outside of design limits, improper repair, or unauthorized modification. This WARRANTY is VOID if the unit shows evidence of having been tampered with or shows evidence of having been damaged as a result of excessive corrosion; or current, heat, moisture or vibration; improper specification; misapplication; misuse or other operating conditions outside of OMEGA's control. Components in which wear is not warranted, include but are not limited to contact points, fuses, and triacs.

**OMEGA is pleased to offer suggestions on the use of its various products. However, OMEGA neither assumes responsibility for any omissions or errors nor assumes liability for any damages that result from the use of its products in accordance with information provided by OMEGA, either verbal or written. OMEGA warrants only that the parts manufactured by the company will be as specified and free of defects. OMEGA MAKES NO OTHER WARRANTIES OR REPRESENTATIONS OF ANY KIND WHATSOEVER, EXPRESSED OR IMPLIED, EXCEPT THAT OF TITLE, AND ALL IMPLIED WARRANTIES INCLUDING ANY WARRANTY OF MERCHANTABILITY AND FITNESS FOR A PARTICULAR PURPOSE ARE HEREBY DISCLAIMED. LIMITATION OF LIABILITY: The remedies of purchaser set forth herein are exclusive, and the total liability of OMEGA with respect to this order, whether based on contract, warranty, negligence, indemnification, strict liability or otherwise, shall not exceed the purchase price of the component upon which liability is based. In no event shall OMEGA be liable for consequential, incidental or special damages.**

CONDITIONS: Equipment sold by OMEGA is not intended to be used, nor shall it be used: (1) as a "Basic Component" under 10 CFR 21 (NRC), used in or with any nuclear installation or activity; or (2) in medical applications or used on humans. Should any Product(s) be used in or with any nuclear installation or activity, medical application, used on humans, or misused in any way, OMEGA assumes no responsibility as set forth in our basic WARRANTY/DISCLAIMER language, and, additionally, purchaser will indemnify OMEGA and hold OMEGA harmless from any liability or damage whatsoever arising out of the use of the Product(s) in such a manner.

## RETURN REQUESTS/INQUIRIES

Direct all warranty and repair requests/inquiries to the OMEGA Customer Service Department. **BEFORE RETURNING ANY PRODUCT(S) TO OMEGA, PURCHASER MUST OBTAIN AN AUTHORIZED RETURN (AR) NUMBER FROM OMEGA'S CUSTOMER SERVICE DEPARTMENT (IN ORDER TO AVOID PROCESSING DELAYS).** The assigned AR number should then be marked on the outside of the return package and on any correspondence.

The purchaser is responsible for shipping charges, freight, insurance and proper packaging to prevent breakage in transit.

FOR **WARRANTY** RETURNS, please have the following information available BEFORE contacting OMEGA:

1. Purchase Order number under which the product was PURCHASED,
2. Model and serial number of the product under warranty, and
3. Repair instructions and/or specific problems relative to the product.

FOR **NON-WARRANTY** REPAIRS, consult OMEGA for current repair charges. Have the following information available BEFORE contacting OMEGA:

1. Purchase Order number to cover the COST of the repair,
2. Model and serial number of the product, and
3. Repair instructions and/or specific problems relative to the product.

OMEGA's policy is to make running changes, not model changes, whenever an improvement is possible. This affords our customers the latest in technology and engineering.

OMEGA is a registered trademark of OMEGA ENGINEERING, INC.

© Copyright 2011 OMEGA ENGINEERING, INC. All rights reserved. This document may not be copied, photocopied, reproduced, translated, or reduced to any electronic medium or machine-readable form, in whole or in part, without the prior written consent of OMEGA ENGINEERING, INC.

# Where Do I Find Everything I Need for Process Measurement and Control? **OMEGA...Of Course!** *Shop online at [omega.com](http://omega.com)<sup>SM</sup>*

## **TEMPERATURE**

- ☑ Thermocouple, RTD & Thermistor Probes, Connectors, Panels & Assemblies
- ☑ Wire: Thermocouple, RTD & Thermistor
- ☑ Calibrators & Ice Point References
- ☑ Recorders, Controllers & Process Monitors
- ☑ Infrared Pyrometers

## **PRESSURE, STRAIN AND FORCE**

- ☑ Transducers & Strain Gages
- ☑ Load Cells & Pressure Gages
- ☑ Displacement Transducers
- ☑ Instrumentation & Accessories

## **FLOW/LEVEL**

- ☑ Rotameters, Gas Mass Flowmeters & Flow Computers
- ☑ Air Velocity Indicators
- ☑ Turbine/Paddlewheel Systems
- ☑ Totalizers & Batch Controllers

## **pH/CONDUCTIVITY**

- ☑ pH Electrodes, Testers & Accessories
- ☑ Benchtop/Laboratory Meters
- ☑ Controllers, Calibrators, Simulators & Pumps
- ☑ Industrial pH & Conductivity Equipment

## **DATA ACQUISITION**

- ☑ Data Acquisition & Engineering Software
- ☑ Communications-Based Acquisition Systems
- ☑ Plug-in Cards for Apple, IBM & Compatibles
- ☑ Data Logging Systems
- ☑ Recorders, Printers & Plotters

## **HEATERS**

- ☑ Heating Cable
- ☑ Cartridge & Strip Heaters
- ☑ Immersion & Band Heaters
- ☑ Flexible Heaters
- ☑ Laboratory Heaters

## **ENVIRONMENTAL MONITORING AND CONTROL**

- ☑ Metering & Control Instrumentation
- ☑ Refractometers
- ☑ Pumps & Tubing
- ☑ Air, Soil & Water Monitors
- ☑ Industrial Water & Wastewater Treatment
- ☑ pH, Conductivity & Dissolved Oxygen Instruments