

1 YEAR
WARRANTY

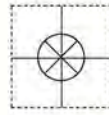

User's Guide



Shop online at

omega.com[®]

Ω OMEGA[®]

omega.com

e-mail: info@omega.com

For latest product manuals:

omegamanual.info

ISO 9001
CERTIFIED
CORPORATE QUALITY

STAMFORD, CT

ISO 9001
CERTIFIED
CORPORATE QUALITY

MANCHESTER, UK

LVU800 Series **Ultrasonic Level Transmitter**



OMEGAnet® Online Service
omega.com

Internet e-mail
info@omega.com

Servicing North America:

U.S.A.:
ISO 9001 Certified

Omega Engineering, Inc., One Omega Drive, P.O. Box 4047
Stamford, CT 06907-0047 USA

Toll Free: 1-800-826-6342
FAX: (203) 359-7700

TEL: (203) 359-1660
e-mail: info@omega.com

Canada:

976 Bergar
Laval (Quebec), Canada H7L 5A1

Toll-Free: 1-800-826-6342
FAX: (514) 856-6886

TEL: (514) 856-6928
e-mail: info@omega.ca

For immediate technical or application assistance:

U.S.A. and Canada: Sales Service: 1-800-826-6342/1-800-TC-OMEGA®
Customer Service: 1-800-622-2378/1-800-622-BEST®
Engineering Service: 1-800-872-9436/1-800-USA-WHEN®

Mexico:

En Español: 001 (203) 359-7803
info@omega.com.mx

FAX: (001) 203-359-7807
e-mail: espanol@omega.com

Servicing Europe:

Benelux:

Managed by the United Kingdom Office
Toll-Free: 0800 099 3344
FAX: +31 20 643 46 43

TEL: +31 20 347 21 21
e-mail: sales@omega.nl

Czech Republic:

Frystatska 184
733 01 Karviná, Czech Republic
Toll-Free: 0800-1-66342
FAX: +420-59-6311114

TEL: +420-59-6311899
e-mail: info@omegashop.cz

France:

Managed by the United Kingdom Office
Toll-Free: 0800 466 342
FAX: +33 (0) 130 57 54 27

TEL: +33 (0) 161 37 29 00
e-mail: sales@omega.fr

Germany/Austria:

Daimlerstrasse 26
D-75392 Deckenpfronn, Germany
Toll-Free: 0 800 6397678
FAX: +49 (0) 7056 9398-29

TEL: +49 (0) 7059 9398-0
e-mail: info@omega.de

United Kingdom:
ISO 9001 Certified

OMEGA Engineering Ltd.
One Omega Drive, River Bend Technology Centre, Northbank
Irlam, Manchester M44 5BD England
Toll-Free: 0800-488-488
FAX: +44 (0)161 777-6622

TEL: +44 (0)161 777-6611
e-mail: sales@omega.co.uk

It is the policy of OMEGA Engineering, Inc. to comply with all worldwide safety and EMC/EMI regulations that apply. OMEGA is constantly pursuing certification of its products to the European New Approach Directives. OMEGA will add the CE mark to every appropriate device upon certification.

The information contained in this document is believed to be correct, but OMEGA accepts no liability for any errors it contains, and reserves the right to alter specifications without notice.

WARNING: These products are not designed for use in, and should not be used for, human applications.

The LVU800 Series is a general-purpose ultrasonic level transmitter that provides a loop powered 4-20 mA output. The 4-20 mA output can be used to provide the proportional level of liquid in any tank or vessel. The signal can be connected to any device that accepts a loop powered 4-20 mA signal, such as a PLC, SCADA, DCS, display, controller, etc.

New Features

- Simple configuration with push button configuration
- Adjustable Loop Fail-Safe, Hold Last, Empty, Full, 21 mA, 22 mA
- Easy to reverse mA output, 4-20 mA to 20-4 mA
- Increased output filtering

Table of Contents

Introduction	3
Specifications	4
Dimensions	4
Safety Precautions:	5
About this manual.....	5
Components.....	6
Getting Started.....	7
Feature Guide	7
Getting Around	8
How to enter the MENU	9
How to configure UNITS.....	9
How to configure the DISPLAY	10
How to configure the operational range (Height & Fill-H)	11
How to reverse the current output (Rev mA).....	12
How to set the Fail-Safe (SAFE) settings	12
How to set Target Calibration (TG CAL)	13
Wiring	14
Installation	16
Mounting Guide	16
Fitting Selection	17
Appendix	20
SETUP	20
Diagnostic (DIAG) parameters	20
Reset	20
User Settings	21
Troubleshooting.....	22

SPECIFICATIONS/DIMENSIONS**Step Two**

Range:	LVU809: 4" to 9.8' (10 cm to 3m) LVU816: 8" to 18.0' (20 cm to 5.5m) LVU826: 8" to 26.4' (20 cm to 8m) LVU832: 12" to 32.8' (30 cm to 10m)
Accuracy:	± 0.2% of range
Resolution:	LVU809: 0.019" (0.5mm) LVU816/826: 0.039" (1mm) LVU832: 0.078" (2mm)
Dead band:	LVU809: 4" (10cm) LVU816/826: 8" (20cm) LVU832: 12" (30cm)
Beam width:	LVU809: 2" (5cm) LVU816/826/832: 3" (7.6 cm) dia.
Configuration:	Push button
Memory:	Non-volatile
Display type:	LCD, 6-digit
Display units:	Inch, cm, Feet, m or percent
Supply voltage:	12-28 VDC

Loop resist.:	500 Ohms @ 24 VDC
Signal output:	4-20 mA, two-wire
Signal invert:	4-20 mA / 20-4 mA
Signal fail-safe:	4mA, 20 mA, 21 mA, 22 mA, hold last
Process temp.:	F: -4° to 140° C: -20° to 60°
Temp. comp.:	Automatic
Ambient temp.:	F: -31° to 140° C: -35° to 60°
Pressure:	MWP = 30 PSI
Enclosure rating:	NEMA 4X (IP65)
Encl. material:	PC/ABS FR
Encl. hardware:	Brass and stainless
Enclosure vent:	Water tight membrane
Conduit entrance:	Dual, 1/2" NPT
Trans. material:	PVDF
Process mount:	LVU809: 1" NPT / 1" G LVU816/826/832: 2" NPT / 2" G
Mount. gasket:	FKM
Classification:	General purpose
Compliance:	CE, RoHS

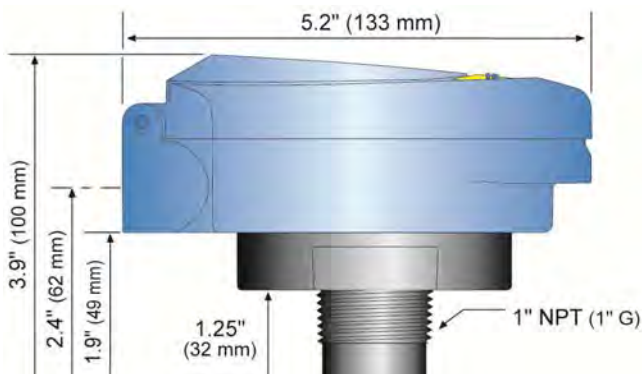
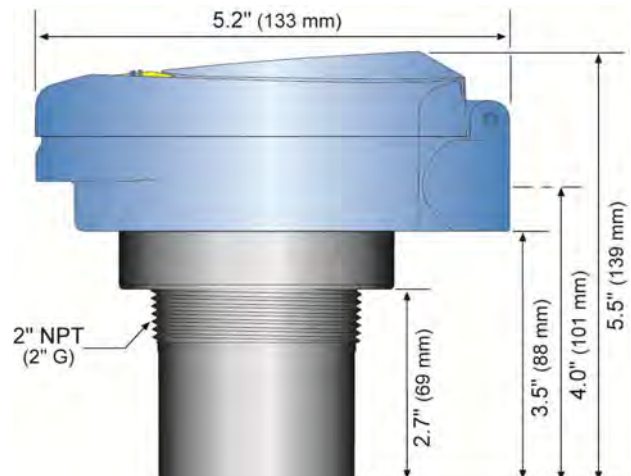
Dimensions:**Side View / LVU809 Series****Side View / LVU816, LVU826 and LVU832 Series**

About this Manual: PLEASE READ THE ENTIRE MANUAL PRIOR TO INSTALLING OR USING THIS PRODUCT. This manual includes information on the LVU800 Series Ultrasonic Level Switch from OMEGA ENGINEERING. Please refer to the part number located on the switch label to verify the exact model configuration, which you have purchased.

User's Responsibility for Safety: OMEGA ENGINEERING manufactures a broad range of level sensing technologies. While each of these sensors is designed to operate in a wide variety of applications, it is the user's responsibility to select a sensor model that is appropriate for the application, install it properly, perform tests of the installed system, and maintain all components. The failure to do so could result in property damage or serious injury.

Proper Installation and Handling: Only professional staff should install and/or repair this product. Install the switch with the included FKM gasket and never over tighten the switch within the fitting. Always check for leaks prior to system start-up.

Wiring and Electrical: A supply voltage of 12 to 28 VDC is used to power the LVU800 Series. Electrical wiring of the transmitter should be performed in accordance with all applicable national, state, and local codes.

Material Compatibility: The enclosure is made of Polycarbonate (PC). The transducer is made of Polyvinylidene Fluoride (PVDF). Make sure that the model, which you have selected, is chemically compatible with the application media.

Enclosure: While the switch housing is liquid-resistant the LVU800 Series is not designed to be operational when immersed. It should be mounted in such a way that the enclosure and transducer do not come into contact with the application media under normal operational conditions.

The enclosure has a flip cover with dual 1/2" NPT female conduit ports and an internal terminal strip for wiring. To open the enclosure, you will need a small insertion tool such as a screwdriver. Loosen the locking screw located at the top front of the enclosure. Rotate the hinged cover up for 135° access to the faceplate and terminal strips. Before closing the enclosure, make sure that the enclosure gasket is properly seated, and that any conduit fittings, cable connectors or plugs are installed correctly and sealed.

Handling Static-Sensitive Circuits/Devices: When handling the transmitter, the technician should follow these guidelines to reduce any possible electrostatic charge build-up on the technician's body and the electronic part.

1. Always touch a known good ground source before handling the part. This should be repeated while handling the part and more frequently after sitting down from a standing position, sliding across the seat or walking a distance.
2. Avoid touching electrical terminals of the part unless making connections.
3. DO NOT open the unit cover until it is time to calibrate.

Make a Fail-Safe System: Design a fail-safe system that accommodates the possibility of switch and/or power failure. OMEGA ENGINEERING recommends the use of redundant backup systems and alarms in addition to the primary system.

Flammable, Explosive or Hazardous Applications: *LVU800 Series should not be used within classified hazardous environments.*

Warning: Always use the FKM gasket when installing the LVU800 Series, and make sure that all electrical wiring of the switch is in accordance with applicable codes.

Components: LVU800 Series is offered in three different models. Depending on the model purchased, you may or may not have been shipped all the components shown below. You do however, need an LVU800 Series and FKM gasket to configure, install and operate LVU800 Series.

- LVU800 Series
 - LVU809 – 9.8' (3 m) range, Type 4X encl., 1" NPT
 - LVU809-G – 9.8' (3 m) range, Type 4X encl., 1" G
 - LVU816 – 18.0' (5.5 m) range, Type 4X encl., 2" NPT
 - LVU816-G – 18.0' (5.5 m) range, Type 4X encl., 2" G
 - LVU826 – 26.2' (8 m) range, Type 4X encl., 2" NPT
 - LVU826-G – 26.2' (8 m) range, Type 4X encl., 2" G
 - LVU832 – 32.8' (10 m) range, Type 4X encl., 2" NPT
 - LVU832-G – 32.8' (10 m) range, Type 4X encl., 2" G
- FKM Gasket
 - Part #220128 – for LVU809 series only
 - Part #220129 – for LVU816, LVU826 and LVU832 series
- Manual

LVU800 Series can be configured before installation. The switch features non-volatile memory, so the set points configured before installation will not be lost when the switch is powered down. To start, all you need is the following information:

- Basic Tank Information:
 - **HEIGHT** – Distance from the transducer face to the bottom of the tank.
 - **FILL-H** – Maximum fill height of the liquid from the bottom of the tank.
 - These values will all be in the same distance value (inches, centimeters, feet or meters) and will all be measured from the bottom of the tank.
- Power:
 - Provide 12 to 28 VDC input power to the LVU800 Series.

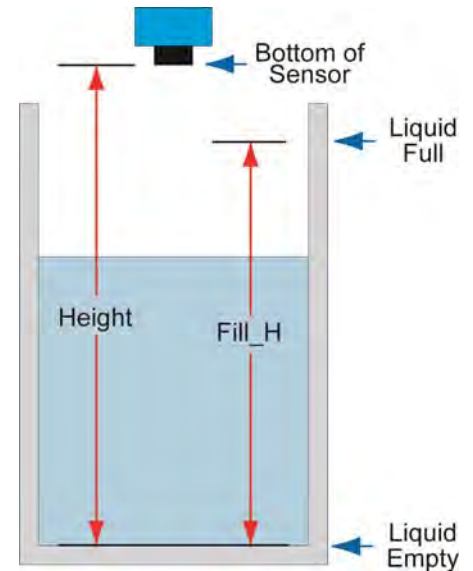

Feature Guide:

FEATURE	ACCESS BY
Easy to use MENU	Press and hold SELECT key until MENU is displayed approximately 5 seconds. The MENU items will rotate through display, press SELECT to change an item.
Many UNITS of measurement.	In the MENU mode, press SELECT when UNITS is display, then select INCHES , CM (centimeter), FEET , METERS or PERCENT .
No cumbersome measure required. Set point distances are relative to the tank bottom.	In MENU mode, select the TANK item and set the HEIGHT of the tank from the transducer face to the bottom of the tank. Set the Fill Height (FILL-H) to the maximum fill height of the liquid from the bottom of the tank. Now all of the set points are from the bottom of the tank up.
Optional Target Calibration	Use this feature if the tank is at the empty or full setting. This will accept the current level as either empty (TG CAL EMPTY) or full (TG CAL FULL).
Fail-Safety	Use the SAFE function to preset the output to either Empty (4 mA), Full (20 mA , 21 mA or 22 mA) or Hold Last Value in case the transmitter loses its signal (LOST).

Getting Around:

LVU800 Series is configured by the use of three push buttons (UP, DOWN and SELECT) and a LCD display. As a lockout feature, the buttons are inactive until the SELECT button is held down for 5 seconds, and then the display will begin to scroll through the top level of the configuration menu.

Steps for Basic Configuration:

1. Select and Set the units of operation in the **UNITS** menu.
2. Configure the Sensor **Height** and **Fill-H** under the **TANK** menu.
3. Set the **SAFE** value.

Top Level

- The Configuration menu will continue to scroll through the items below until the **SELECT** button is pressed.
- **UNITS – TANK – SAFE – TG CAL – VALUES - HELP – RUN.**
- To return to the Operational mode of LVU800 Series, press *SELECT* while RUN appears in the display.
- **UNITS** – Allows end user to select the units for configuration and operation. Select between Inches, Centimeters, Feet, Meters or Percent. Press *EXIT* to return to the Top Level menu.
- **TANK** – Allows the end user to configure the operational range for the switch.
 - **HEIGHT** – Distance from the transducer face to the bottom of the tank.
 - **FILL-H** – Maximum fill height of the liquid from the bottom of the tank.
 - **REV MA** – Allows the transmitter to reverse the current output such that 4 mA is at FULL and 20 mA is at EMPTY.
 - Press *Exit* to return to the Top level Menu.
 - **Note:** if UNITS is set to Percent, then TANK will not appear. To view TANK, set UNITS to any of the following: Inches, Centimeters, Feet or Meters.
- **SAFE** – The fail-safe for the LVU800 Series can be preset to the customer's requirement.
 - **22 mA** – Overfill fail-safe setting.
 - **21 mA** – Overfill fail-safe setting.
 - **20 mA** – Full fail-safe setting.
 - **4 mA** – Empty fail-safe setting.
 - **HOLD** – Keeps the output at its last current reading when fail-safe condition occurs.
- **TG CAL** – Target Calibration (allows for the sensor to accept the current level as either EMPTY or FULL.
- **VALUES** – Provides setup information, the ability to reset the LVU800 Series and a simulation mode to test the relay function.
 - **SETUP** – Will display the setting for all functions of LVU800 Series.
 - **DIAG** – This is a production test feature used by the factory to confirm operation. ***This mode should only be used when supervised by an Omega Engineering representative.***
 - **RESET** – Will reset the LVU800 Series back to its original factory setting.
- **HELP** – Provides information for contacting Omega Engineering no-line.
- **RUN** – Returns the unit to normal measurement and control mode.

How to enter the MENU:

1. Press and hold *SELECT* key (approximately 5 seconds) until **MENU** is displayed.
2. The menu items will rotate through display.
3. Press *SELECT* to change an item.

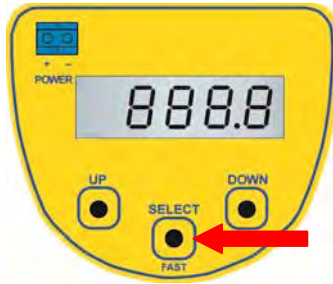
**How to configure UNITS:**

1. In the **MENU** mode, press select when **UNITS** is display.
2. Press *SELECT* to choose between **INCHES**, **CM** (centimeter), **FEET**, **METERS** or **PERCENT**.
3. Select *EXIT* to return to the Top Level Menu.

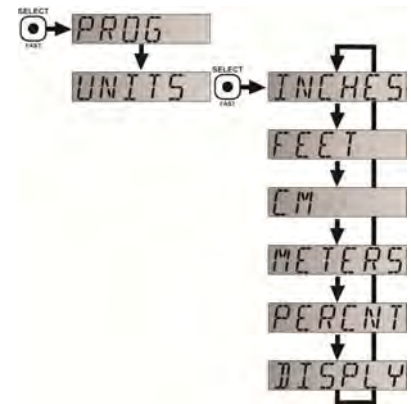
**Note: Reading the level of liquid in Percent:**

- Omega Engineering recommends that when selecting **PERCENT**, configure the **HEIGHT** and **FILL-H** settings before selecting **PERCENT** in order to span the LVU800 Series for your application requirements.
- When in **PERCENT**, the operational span will be based upon the last **TANK** settings, typically the factory settings for **HEIGHT** and **FILL-H**.

LVU800 Series	HEIGHT	FILL-H
LVU809 Series	118.1" (300 cm)	114.1" (290 cm)
LVU816 Series	216.5" (550 cm)	208.5" (530 cm)
LVU826 Series	314.9" (800 cm)	307.1" (780 cm)
LVU832 Series	393.7" (1000 cm)	381.9" (970 cm)

- When **PERCENT** is selected, the **TANK** settings (**HEIGHT** and **FILL-H**) will be disabled.

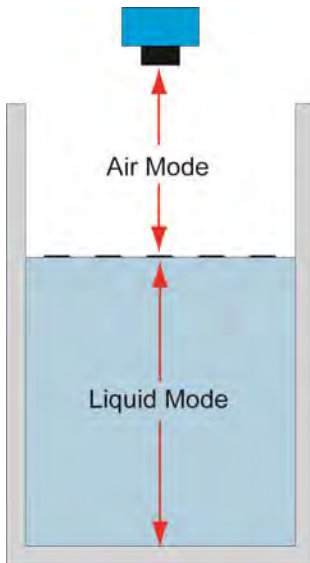
DISPLAY - AIR Mode vs. LIQUID Mode:

The display can be made to display either the height of liquid in the tank (**LIQUID** mode) or the amount of air in the tank (**AIR** mode).

AIR mode – Will display the distance from the bottom of the sensor to the surface of the liquid.

LIQUID mode – Will display the height of liquid measured from the bottom of the tank.

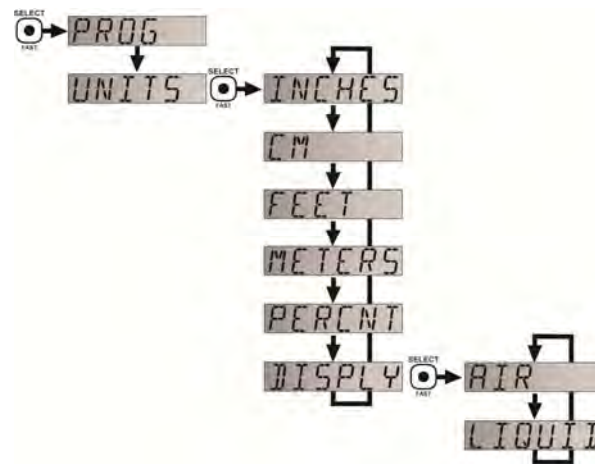
**How to change the display mode:**

1. In the **MENU** mode, press **SELECT** when **UNITS** is display.
2. Press **SELECT** when **DISPLAY** appears.
3. Press **SELECT** to choose between **AIR** or **LIQUID**.
4. When **EXIT** appears, press **SELECT** return to Top Level Menu.

How to configure the Operational range of LVU800 Series:

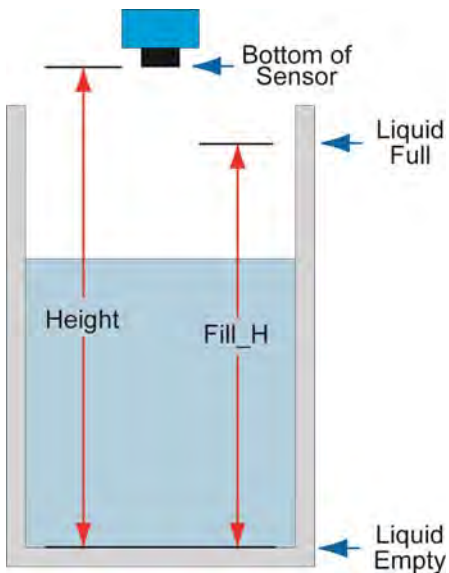

No cumbersome measurement is required via Target Calibration to establish set points. Set point distances are relative to the tank bottom.

1. In **MENU** mode, select the **TANK** item.
2. When **HEIGHT** appears, press **SELECT**.
3. Using the **UP** and **DOWN** buttons, set the **HEIGHT** of the tank from the transducer face to the bottom of the tank.
4. To enter the value, press and hold **SELECT** (Approximately 2 seconds) until **SAVED** is displayed.
5. When **FILL-H** appears, press **SELECT**.
6. Using the **UP** and **DOWN** buttons, set the Fill Height (**FILL-H**) to the maximum fill height of the liquid from the bottom of the tank.
7. Press and hold **SELECT** (2 seconds) to enter the value.
8. When **EXIT** appears, press **SELECT** return to Top Level Menu.

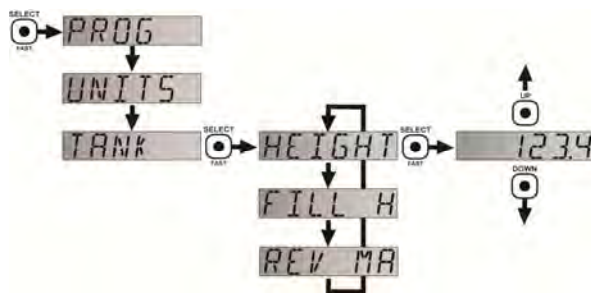

Sensor Height

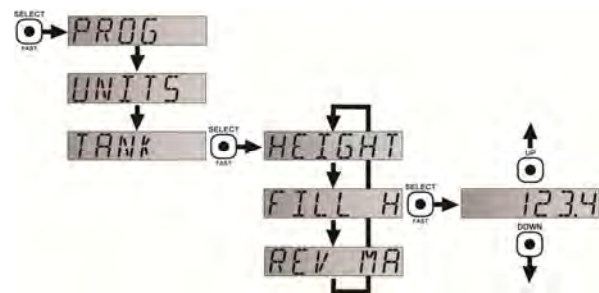

Fill-Height

Note:

- Omega Engineering recommends that when selecting PERCENT, configure the Height and Fill-H settings before selecting PERCENT in order to span the LVU800 Series for your application requirements.
- When PERCENT is selected, the TANK settings (Height and Fill-H) will be disabled.

How to set a Reverse the Current Output:

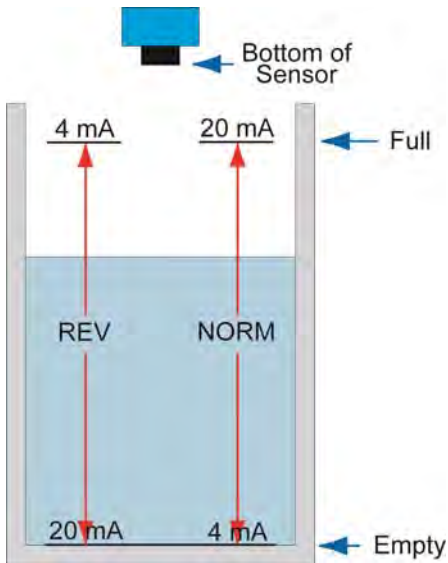

The default for LVU800 Series is to have 4 mA at Empty and 20 mA at Full. This is the normal (**NORM**) setting. The output can be reversed (**REV**) with 20 mA at Empty and 4 mA at Full.

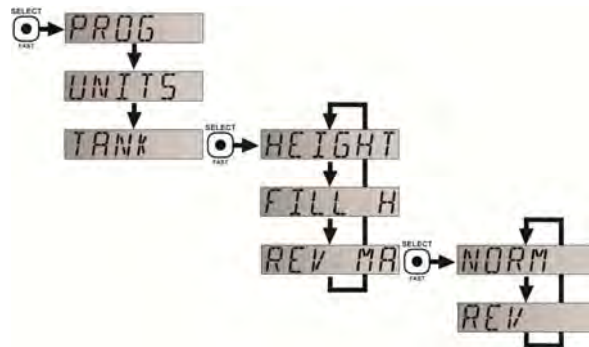

1. In **MENU** mode, select the **TANK** item.
2. When **REV MA** appears, press **SELECT**.
3. When **REV** appears, press **SELECT**.
4. When **EXIT** appears, press **SELECT** return to Top Level Menu.

LVU800 Series is now in the Reverse mode. To switch back to the Normal mode, follow the instructions above and select **NORM** under step 3.

How to set the SAFE setting:

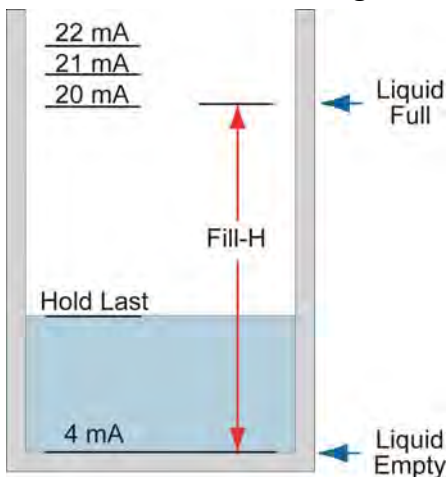

The default for Fail-Safety (LOST) can be preset. The choices are **4 mA**, **20 mA**, **21 mA**, **22 mA** and **HOLD**.

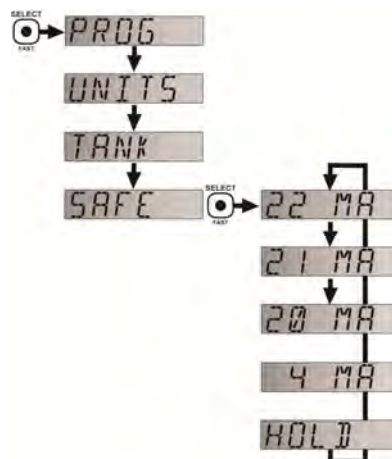

1. In **MENU** mode, select the **SAFE** item.
2. When the required setting appears, press **SELECT**.
3. When **EXIT** appears, press **SELECT** return to Top Level Menu.

How to set using Target Calibration (Empty):

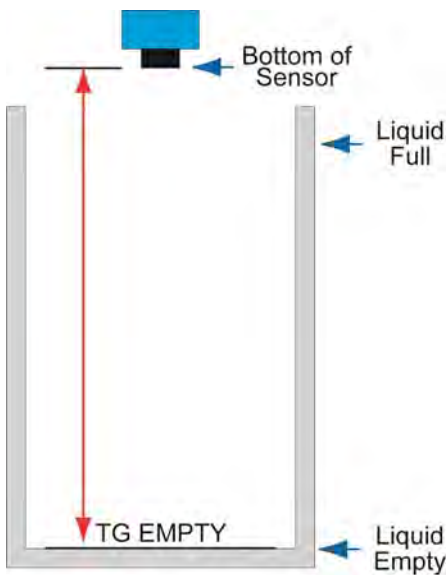

Instead of measuring for Empty tank, the Empty distance can be set automatically. This method requires that the tank be Empty or at the level that is considered Empty in the application. To set **TG Empty**, follow the instructions below.

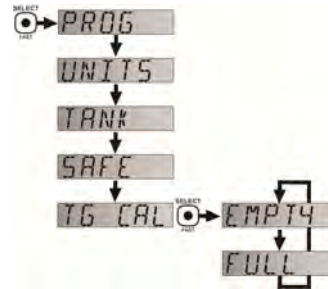

1. Before beginning, make sure the level is tank is at the Empty level.
2. In **MENU** mode, select the **TG CAL** item.
3. When **EMPTY** appears, press **SELECT**. This sets the current distance as the new Empty setting.
4. When **EXIT** appears, press **SELECT** return to Top Level Menu.

How to set using Target Calibration (Full):

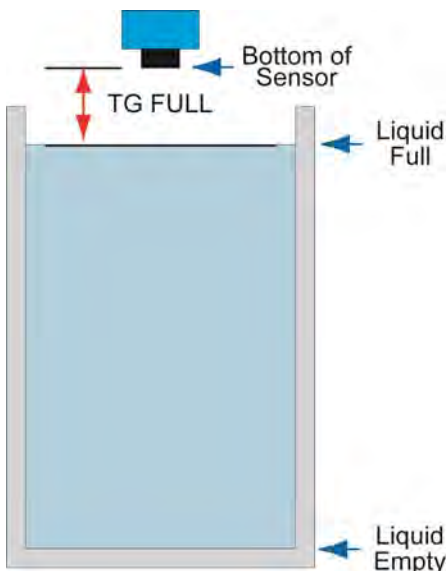

Instead of measuring for Full tank, the Full distance can be set automatically. This method requires that the tank be Full or at the level that is considered Full in the application. To set **TG Full**, follow the instructions below.

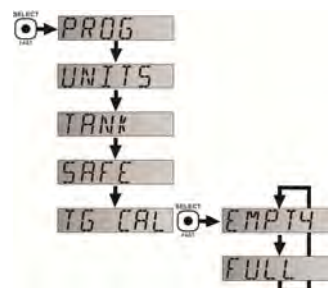

1. Before beginning, make sure the level is tank is at the Full level.
2. In **MENU** mode, select the **TG CAL** item.
3. When **FULL** appears, press **SELECT**. This sets the current distance as the new Full setting.
4. When **EXIT** appears, press **SELECT** return to Top Level Menu.

*Note: When setting either the **TG EMPTY** or **TG FULL**, make sure the reflective surface is perpendicular to the LVU800 Series and not at an angle. Be careful if the tank has a sloped or cone bottom and the bottom of the tank is exposed to air.*

Below is a quick review of wiring the LVU800 Series to common display, controllers and PLC's.

**Proportional Level Controller
LVCN-51 Series
JWA mode (Factory Setting)**

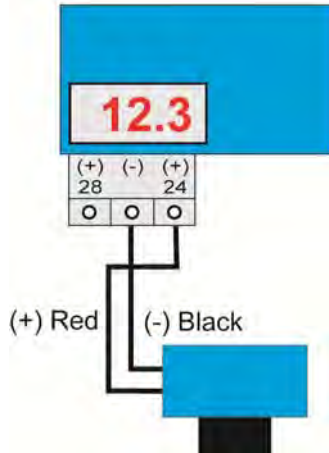

**Proportional Level Controller
LVCN-51 Series
JWB mode**

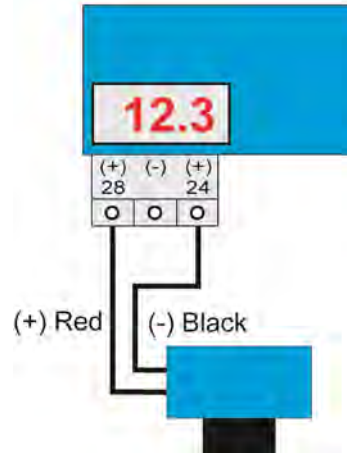

**Generic Loop
Powered Display**

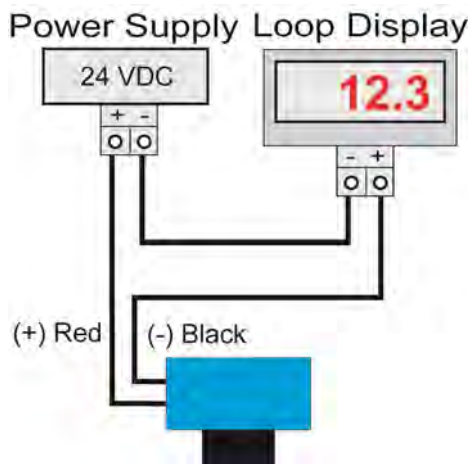

Generic PLC

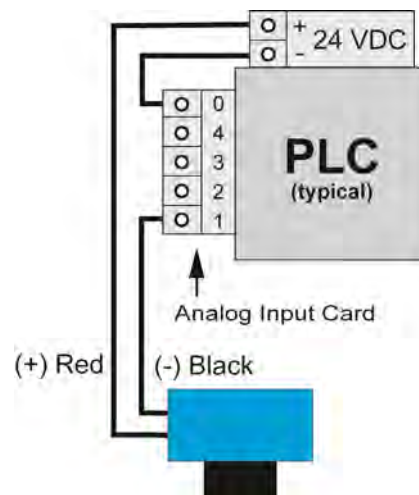

General notes for electrical connections, usage and safety:

- Where personal safety or significant property damage can occur due to a spill, the installation must have a redundant backup safety system installed.
- Wiring should always be completed by a licensed electrician.
- Supply voltage should never exceed 28 VDC.
- The sensor materials must be chemically compatible with the liquids to be measured.
- Design a fail-safe system for possible sensor and/or power failure.
- Never use the sensor in environments classified as **Hazardous**.

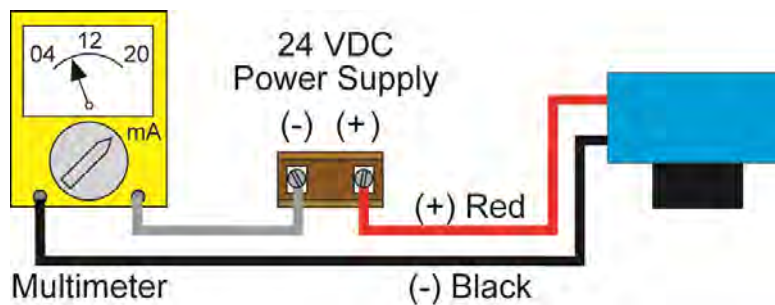
Testing the Transmitter

1. Connect a multimeter in series with the black wire to read the current output.
2. Verify that the current increases (tank filling) and decreases (tank emptying) appropriately in the calibrated span.
3. If not, carefully observe and attempt to correlate any installation, level or application event for more specific troubleshooting direction.

Voltage Output

LVU800 Series can be used as a 0 to 5 or 0 to 10 VDC output device. A resistor will need to be added to the circuit to enable a voltage output (refer to the wiring diagram below).

- 0-5 VDC output
 - Add a 250 Ohm resistor
 - Actual output will be 0.8 to 5 VDC
- 0-10 VDC output
 - Add a 500 Ohm resistor
 - Actual output will be 2 to 10 VDC

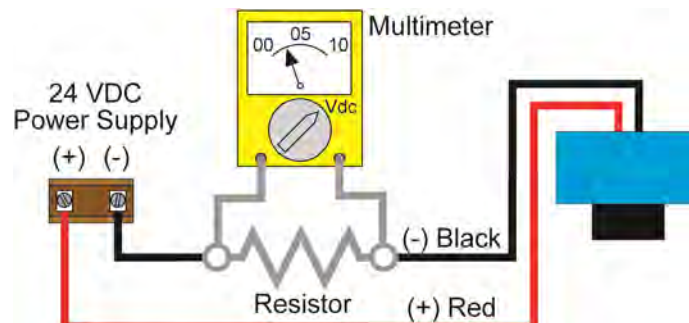

The LVU800 Series should always be mounted perpendicular to the liquid surface and installed using the provided FKM mounting gasket. Make sure that the fitting and transmitter threads are not damaged or worn. Always *hand-tighten* the transmitter within the fitting. Perform an installed leak test under normal process conditions prior to system start up. **Note:** *The preferred mounting fitting for the LVU809 series is a plastic 2" thread (or slip) x 1" thread reducer bushing.*

Mounting Guide

1. Do not mount at an angle
2. Liquid should never enter the dead band
3. Side Wall:
 - a. For LVU809 Series - mount at least 2" from the side wall
 - b. For LVU816, LVU826 & LVU832 Series - mount at least 3" from the side wall
4. Do not mount where obstacles will intrude on sensor's beam width
 - a. See Specifications on page 4
5. Do not mount in a vacuum
6. Avoid mounting in the center of a dome top tank.
7. In cone bottom tank, position the sensor over the deepest part of the tank.

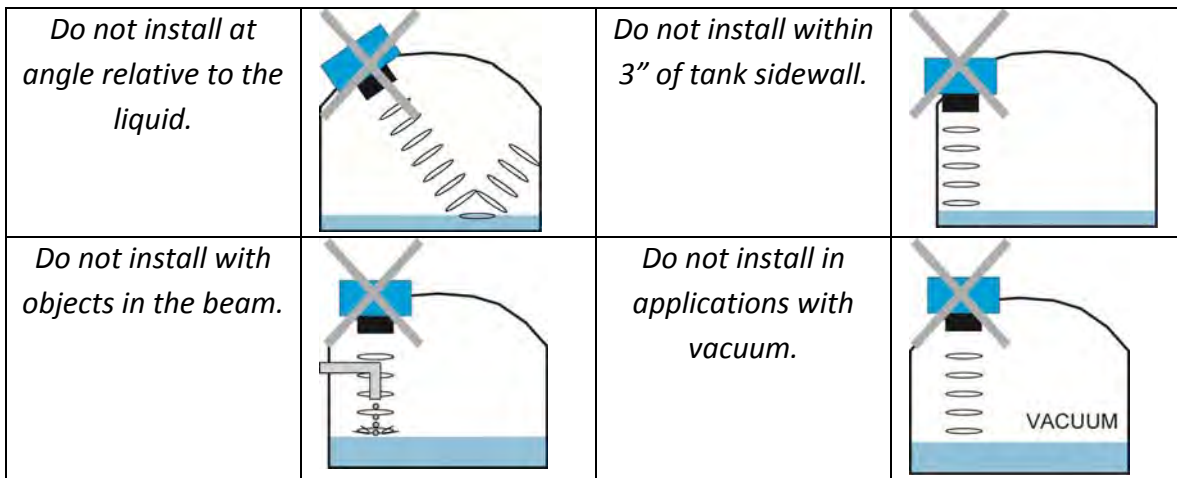

Installation in existing fittings

If the existing fitting is larger than the threads of the LVU800 Series, select a reducer bushing such as a 2" thread x 1" thread, a 2" slip x 1" thread, 3" thread x 2" thread or 3" slip x 2" thread.

Metal Tanks (LVU809 series only)

Omega Engineering ultrasonic transmitters have been optimized for use in non-metallic fittings.

1. For best performance, avoid the use of metallic fittings.
 - a. Use a plastic 2" x 1" reducer bushing (such as LVU800-2N80), or a plastic 1" tank adapter (such as LVU800-1B).
2. While installations directly into a 1" metal fitting are not recommended, acceptable results may be obtained if the 1" fitting is a half coupling in form and the outer diameter of the coupling is tightly wrapped in vinyl tape to dampen vibrations.

Fitting Selection: Check the part number to determine the required fitting mount size and thread type. LVU800 Series is commonly installed in tank adapters, flanges, brackets or standpipes. Note: Always include the gasket when installing the LVU800 Series.

1. **Tank Adapter:** Select a tank adapter fitting, such as a 1" adapter for the LVU809 series or a 2" adapter for the LVU816, LVU826 & LVU832 series.
 - a. *For best results, select a 2" tank adapter and add a 2" x 1" reducer bushing.*
 - b. Avoid tank adapter (thread x thread) styles and/or pipe stops forward of the installed transducer.
 - c. Always mount the tank adapter so the majority of fitting is outside the tank.
 - i. Never mount the tank adapter upside down or the bulk of the material is inside the tank.

**2" Tank Adapter
Socket x Thread
(LVU800-2B shown)**



**Tank Adapter (LVU800-2B)
w/ Reducer Bushing
(LVU800-2N80 shown)**



**2" Tank Adapter
Thread x Thread**



Do not use thread x thread

2. **Riser:** Installations with tall, narrow risers can impede the acoustic signal.
 - a. **LVU816, LVU826 & LVU832 Series:** 2" (5 cm) diameter risers should be no taller than 5" (12.7 cm). Larger diameter risers should be no taller than 12" (30.5 cm).
 - b. **LVU809 Series:**

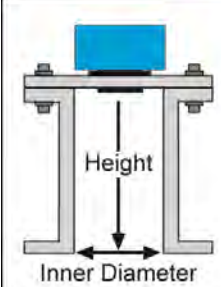
	Riser Specifications	
	Inner Diameter	Maximum Height
2" (5 cm)	3" (7.6 cm)	
4" (10 cm)	8" (20 cm)	
6" (15 cm)	12" (30 cm)	

Note: Do not exceed the dimensions listed above

3. **Flange (LVU809 series):** If installing on a flange, select a flange with a thread that is above the plane of the flange.
 - a. *The LVU816, LVU826 & LVU832 series works well with Flange installations.*
 - b. Avoid the use of blind flanges with tapped threads or flanges where the threads are even with the plane of the flange, such as the Banjo 1" Poly ANSI Flange (series AF100).
 - c. Use a flange with a 2" thread and add a 2" to 1" reducer bushing to complete the installation.

**2" Flange w/
thread out of plane
(LVU800-2F shown)**



**2" Flange w/
thread in plane**



Do not use thread in plane

**2" Flange w/
Reducer Bushing
(LVU800-2N80 shown)**



4. **Side Mount Bracket:** For installations in open tanks and sumps, use the LVM-30 or LVM-31 series side mount bracket.
 - a. For the LVU809 series, order the LVM-31 side mount bracket.
 - b. For the LVU816, LVU826 & LVU832, series, order the LVM-30 side mount bracket.

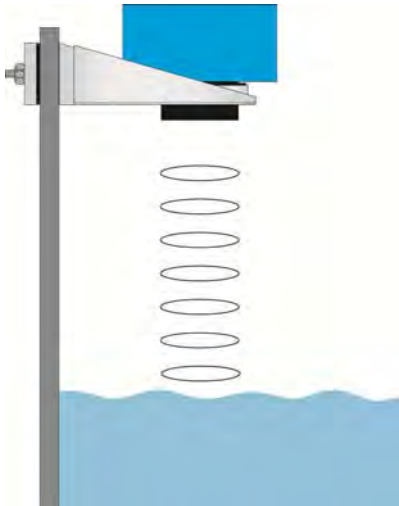

5. **Stand Pipe:** A standpipe maybe used to dampen turbulence or when foam is present in the application.
- Pipe can be made of any material.
 - Select a minimum 3" ID pipe for the stand pipe.
 - A 2" pipe is usable with the LVU809 series, but is the minimum.
 - Pipes larger than 3" can also be used.
 - Use a coupling and reducer bushing to attach the LVU800 Series to the pipe.
 - With the LVU809 series, be sure to use a plastic reducing bushing such as the 2" Thread x 1" Thread fitting (ex: LVU800-2N80) or 2" Slip x 1" Thread fitting (ex: LVU800-2S80).
 - With the LVU816, LVU826 or LVU832 series, be sure to use a plastic reducing bushing such as the 3" Thread x 2" Thread fitting (ex: LVU800-3N80) or 3" Slip x 2" Thread fitting (ex: LVU800-3S80).
 - The pipe length should run the measurement span and the bottom of the pipe should remain submerged at all times to prevent foam from entering the pipe.
 - Cut a 45° notch at the bottom of the pipe and drill a 1/4" pressure equalization hole in the dead band.
 - The pumps should not drive liquid past the open end of the stand pipe which causes the liquid in the pipe to oscillate.

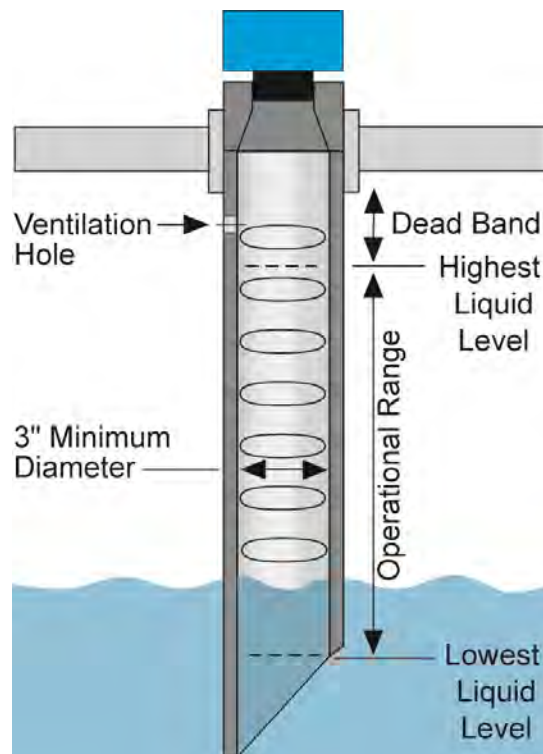

Setup:

You can view how the LVU800 Series is configured.

1. From the main **MENU** level, press *SETUP* when **VALUES** appears.
2. When **SETUP** appears, press the *SELECT* key.
3. Setup will display the following information:
 - a. **Units, Display, Rev mA, Safe, Height, Fill-H**
4. When completed, press *SELECT* when **EXIT** appears to return to the main program level.

Diagnostics (DIAG) Parameters:

This mode runs diagnostic tests that confirm operation of LVU800 Series. *This mode should only be used when supervised by an Omega Engineering representative.*

Reset:

LVU800 Series enables the end user to reset the entire configuration back to the original factory settings.

Follow the instructions below to reset LVU800 Series:

1. From the main **MENU** level, press *SELECT* when **VALUES** appears.
2. When **RESET** appears, press the *SELECT* key.
3. When **YES** appears, press *SELECT* key to reset LVU800 Series.
 - a. To cancel the reset, press *SELECT* when **NO** appears.
4. When completed, press *SELECT* when **EXIT** appears to return to the main program level.

Factory Settings:

LVU800 Series	HEIGHT	FILL-H
LVU809 Series	118.1" (300 cm)	114.1" (290 cm)
LVU816 Series	216.5" (550 cm)	208.5" (530 cm)
LVU826 Series	314.9" (800 cm)	307.1" (780 cm)
LVU832 Series	393.7" (1000 cm)	381.9" (970 cm)

User Settings:

Fill out the chart below and keep as a record of your configuration.

Tank

Height =	Fill-H =
Norm	Reverse

Units

Inches	Feet	cm	Meter	Percent
Air		Liquid		

Safe

22mA	21 mA	20mA	Hold Last	4mA
------	-------	------	-----------	-----

Troubleshooting:

PROBLEM	SOLUTION
TANK does not appear on the main menu:	Units function is set for PERCENT on LVU800 Series: When Units is set for PERCENT , the TANK function is disabled. To re-enable TANK , change units to INCHES , CM , FEET or METERS .
Display shows FULL :	Level of liquid is above the FILL-H setting: Check the FILL-H setting, making sure the FILL-H setting is high enough so the level of liquid is below the FILL-H setting. The Fill-H setting is the distance from the bottom of the tank to the Full level of liquid.
Display shows EMPTY :	Level of liquid is beyond the HEIGHT setting: Check the HEIGHT setting, making sure the HEIGHT setting is low enough so the level of liquid is above the HEIGHT setting.
Display shows WARMUP :	Typically occurs when power is being applied to transmitter. Indicates a weak power supply, bad wire connections or the sensor is out of the operational range.
Display shows LOST :	Sensor is in a Fail-Safe state. The return sound pulses are not reaching the transducer. First, cycle power off and on, waiting 5 seconds between the off and on states. If problem persists, check the installation fitting against the Installation instructions in the manual.
Display is opposite of the measured value:	Check the DISPLAY setting. AIR mode indicates the distance from the liquid to the sensor. LIQUID mode indicates the height of liquid in the tank. Change the DISPLAY mode from AIR to LIQUID or vice versa to correct.
Transmitter indicates a current of 0 mA:	Check the wiring for an open circuit. An open circuit is the most common issue with a 0 mA signal.
Transmitter jumps to a current reading between 19 and 20 mA:	Check the installation of the transmitter. Bad installation fittings will cause false signals near the top of the tank, which typically translates to a signal between 19 and 20 mA. Also look for interference just below the transmitter. If the transmitter is installed in a metal fitting, switch to a plastic fitting.
Transmitter indicates a current over 23 mA:	Immediately check the wiring for a short circuit. The LVU800 Series is current limited to 22 mA. Anything above 23 mA indicates a short circuit.



WARRANTY/DISCLAIMER

OMEGA ENGINEERING, INC. warrants this unit to be free of defects in materials and workmanship for a period of **13 months** from date of purchase. OMEGA's WARRANTY adds an additional one (1) month grace period to the normal **one (1) year product warranty** to cover handling and shipping time. This ensures that OMEGA's customers receive maximum coverage on each product.

If the unit malfunctions, it must be returned to the factory for evaluation. OMEGA's Customer Service Department will issue an Authorized Return (AR) number immediately upon phone or written request. Upon examination by OMEGA, if the unit is found to be defective, it will be repaired or replaced at no charge. OMEGA's WARRANTY does not apply to defects resulting from any action of the purchaser, including but not limited to mishandling, improper interfacing, operation outside of design limits, improper repair, or unauthorized modification. This WARRANTY is VOID if the unit shows evidence of having been tampered with or shows evidence of having been damaged as a result of excessive corrosion; or current, heat, moisture or vibration; improper specification; misapplication; misuse or other operating conditions outside of OMEGA's control. Components in which wear is not warranted, include but are not limited to contact points, fuses, and triacs.

OMEGA is pleased to offer suggestions on the use of its various products. However, OMEGA neither assumes responsibility for any omissions or errors nor assumes liability for any damages that result from the use of its products in accordance with information provided by OMEGA, either verbal or written. OMEGA warrants only that the parts manufactured by the company will be as specified and free of defects. OMEGA MAKES NO OTHER WARRANTIES OR REPRESENTATIONS OF ANY KIND WHATSOEVER, EXPRESSED OR IMPLIED, EXCEPT THAT OF TITLE, AND ALL IMPLIED WARRANTIES INCLUDING ANY WARRANTY OF MERCHANTABILITY AND FITNESS FOR A PARTICULAR PURPOSE ARE HEREBY DISCLAIMED. LIMITATION OF LIABILITY: The remedies of purchaser set forth herein are exclusive, and the total liability of OMEGA with respect to this order, whether based on contract, warranty, negligence, indemnification, strict liability or otherwise, shall not exceed the purchase price of the component upon which liability is based. In no event shall OMEGA be liable for consequential, incidental or special damages.

CONDITIONS: Equipment sold by OMEGA is not intended to be used, nor shall it be used: (1) as a "Basic Component" under 10 CFR 21 (NRC), used in or with any nuclear installation or activity; or (2) in medical applications or used on humans. Should any Product(s) be used in or with any nuclear installation or activity, medical application, used on humans, or misused in any way, OMEGA assumes no responsibility as set forth in our basic WARRANTY/DISCLAIMER language, and, additionally, purchaser will indemnify OMEGA and hold OMEGA harmless from any liability or damage whatsoever arising out of the use of the Product(s) in such a manner.

RETURN REQUESTS/INQUIRIES

Direct all warranty and repair requests/inquiries to the OMEGA Customer Service Department. BEFORE RETURNING ANY PRODUCT(S) TO OMEGA, PURCHASER MUST OBTAIN AN AUTHORIZED RETURN (AR) NUMBER FROM OMEGA'S CUSTOMER SERVICE DEPARTMENT (IN ORDER TO AVOID PROCESSING DELAYS). The assigned AR number should then be marked on the outside of the return package and on any correspondence.

The purchaser is responsible for shipping charges, freight, insurance and proper packaging to prevent breakage in transit.

FOR **WARRANTY** RETURNS, please have the following information available BEFORE contacting OMEGA:

1. Purchase Order number under which the product was PURCHASED,
2. Model and serial number of the product under warranty, and
3. Repair instructions and/or specific problems relative to the product.

FOR **NON-WARRANTY** REPAIRS, consult OMEGA for current repair charges. Have the following information available BEFORE contacting OMEGA:

1. Purchase Order number to cover the COST of the repair,
2. Model and serial number of the product, and
3. Repair instructions and/or specific problems relative to the product.

OMEGA's policy is to make running changes, not model changes, whenever an improvement is possible. This affords our customers the latest in technology and engineering.

OMEGA is a registered trademark of OMEGA ENGINEERING, INC.

© Copyright 2009 OMEGA ENGINEERING, INC. All rights reserved. This document may not be copied, photocopied, reproduced, translated, or reduced to any electronic medium or machine-readable form, in whole or in part, without the prior written consent of OMEGA ENGINEERING, INC.

Where Do I Find Everything I Need for Process Measurement and Control?

OMEGA...Of Course!

Shop online at omega.comSM

TEMPERATURE

- M Thermocouple, RTD & Thermistor Probes, Connectors, Panels & Assemblies
- M Wire: Thermocouple, RTD & Thermistor
- M Calibrators & Ice Point References
- M Recorders, Controllers & Process Monitors
- M Infrared Pyrometers

PRESSURE, STRAIN AND FORCE

- M Transducers & Strain Gages
- M Load Cells & Pressure Gages
- M Displacement Transducers
- M Instrumentation & Accessories

FLOW/LEVEL

- M Rotameters, Gas Mass Flowmeters & Flow Computers
- M Air Velocity Indicators
- M Turbine/Paddlewheel Systems
- M Totalizers & Batch Controllers

pH/CONDUCTIVITY

- M pH Electrodes, Testers & Accessories
- M Benchtop/Laboratory Meters
- M Controllers, Calibrators, Simulators & Pumps
- M Industrial pH & Conductivity Equipment

DATA ACQUISITION

- M Data Acquisition & Engineering Software
- M Communications-Based Acquisition Systems
- M Plug-in Cards for Apple, IBM & Compatibles
- M Datalogging Systems
- M Recorders, Printers & Plotters

HEATERS

- M Heating Cable
- M Cartridge & Strip Heaters
- M Immersion & Band Heaters
- M Flexible Heaters
- M Laboratory Heaters

ENVIRONMENTAL MONITORING AND CONTROL

- M Metering & Control Instrumentation
- M Refractometers
- M Pumps & Tubing
- M Air, Soil & Water Monitors
- M Industrial Water & Wastewater Treatment
- M pH, Conductivity & Dissolved Oxygen Instruments