

FE

Rail Type
Controller

FE250
FE251
FE300

Digital Process Controller



Classic evolution

High-Performance Process Control

High Accuracy $\pm 0.1\%$

Sampling Time 50ms

Speed upper to 115200 bps

DIN rail mounting

Precise control

High Reliability



Excellent Anti-Interference Ability



Passing the highest level of EMC verification in CE certification. It can resist electromagnetic interference in heavy noise environment.

Ultra Low Temperature Drift



Any operating conditions have been considered in the design, even if in temperature variety ambience, it also not affects PV and control performance.

High Speed Sampling And High Accuracy



Input can perform 50ms high-speed sampling, enabling stable control and response. Built-in 18-bit high resolution ADC circuit provides up to 0.1% accuracy.

Certification And Universal Voltage



All models get CE approval. operate on any voltage from AC 85~265V at 50/60 Hz, DC 24V is also available.

DIN Rail Mounting



DIN-rail installation, thin type of body can save lots of space also easy to use in multi-point control and communication.

Parameter Lock Function



All parameters are separated in five operation levels (Level1~Level5). Each parameter can be hidden or locked to prevent users unauthorized changes.

Status Indicator Lamp

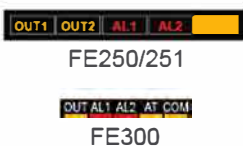

Real time monitor the status of output (OUT1/OUT2), alarm(AL1/AL2), communication(COM) and auto-tuning(AT).

Register Mapping



Compatible with FY series controller, parameter address can be switched by software, without changing original HMI or PLC program.

Function Block Diagram

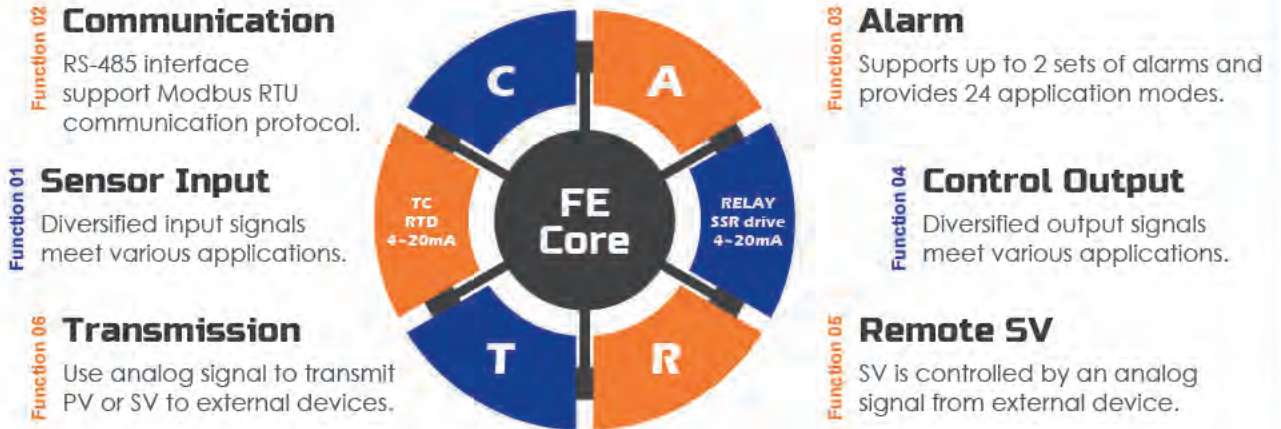

Features

Various I/O Types

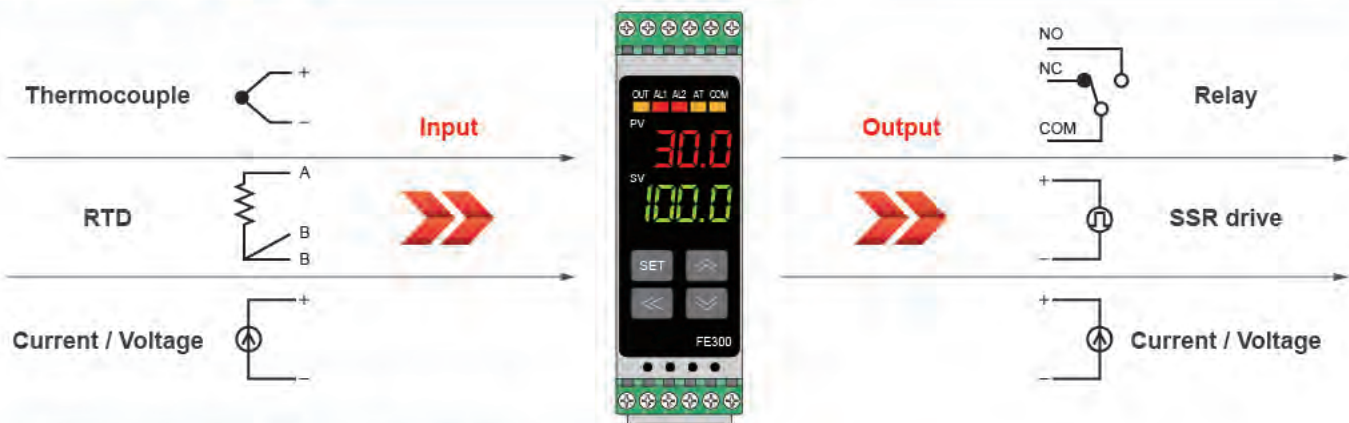

Excellent Control Performance

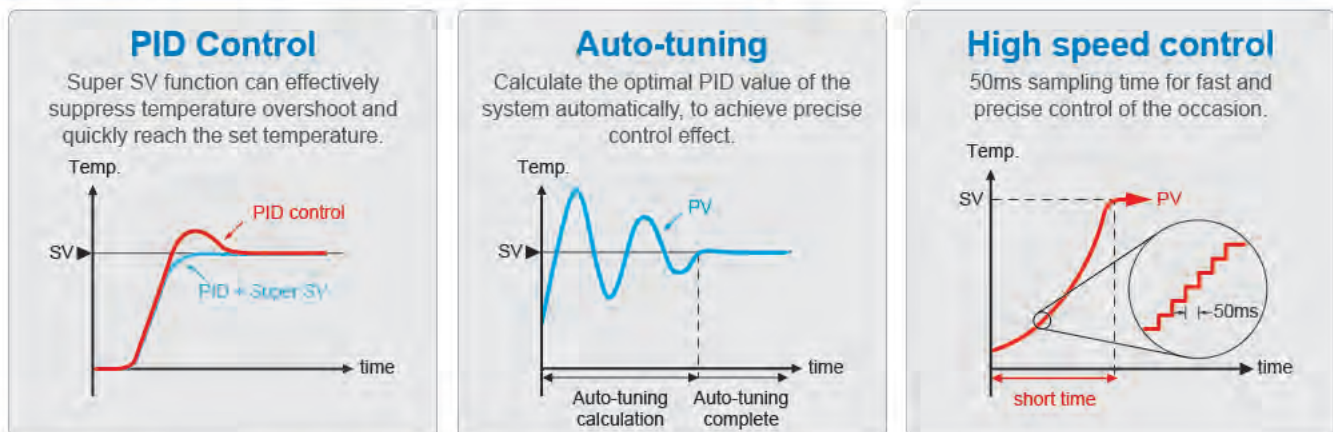

Fast and Stable RS-485 Communication

Compatible with Modbus RTU communication protocol to quickly establish links with HMI, PLC or SCADA software.

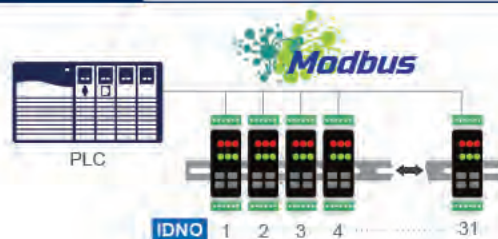

Features

Heating and Cooling Control

Using two outputs of the controller, as long as a controller can control the heating / cooling equipment.

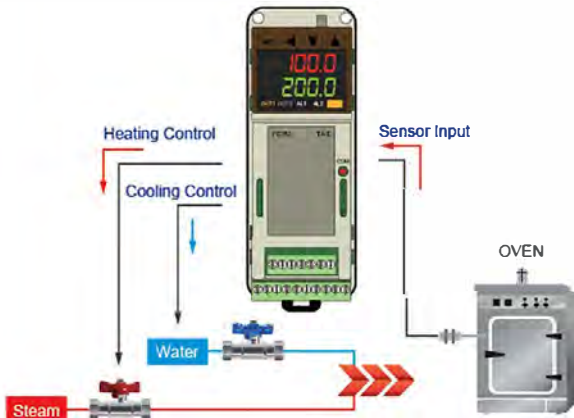

Heater Break Alarm

With a CT (current transformer) to monitor the heater current in real time, when the current value is abnormally reduced an alarm signal can be output to notify the user.

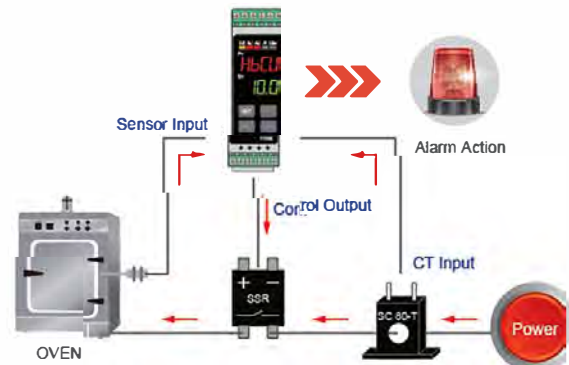

Transmission

Transfer parameter digital values as analog signals to external devices.

signals: 0~20mA 4~20mA 0~5V
1~5V 0~10V.....

parameters: SV1 PV1 MV1.....



Remote SV

SV is controlled by an analog signal from an external device.

signals: 0~20mA 4~20mA 0~5V
1~5V 0~10V.....

parameters: SV

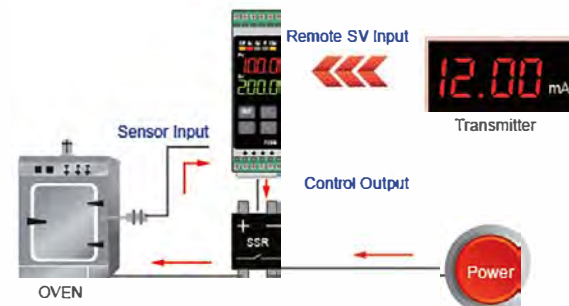

Bumpless Transfer

When the automatic mode is changed to manual mode, the current manipulated value will be loaded, make sure the system not be impacted by sudden changes.

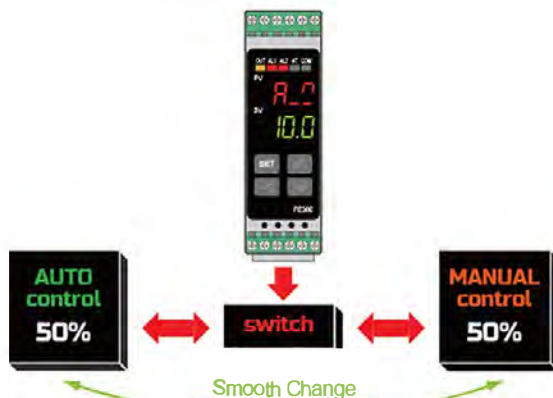

MV% Maintain and Limit

In the high manipulated value can be limited, to protect the system avoid overheating.

In the low manipulated value can be keep, to maintain the system running.



Appearance

Parts Description

FE250 FE251

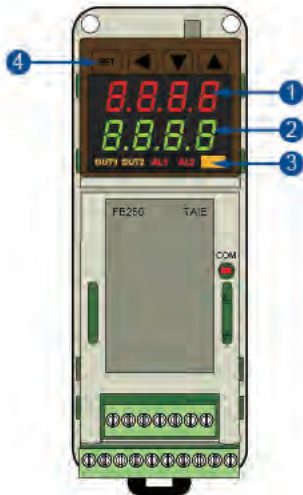

1	PV	Indicates PV (measured value) and character information such as parameter codes and error codes (Red)	
2	SV	Indicates SV (target set value) and parameter Values (Green)	
3	LED	OUT1	Lamp lit when OUT1 is activated (Orange)
		OUT2	Lamp lit when OUT2 is activated (Orange)
		AL1	Lamp lit when Alarm 1 is activated (Red)
		AL2	Lamp lit when Alarm 2 is activated (Red)
		□	Lamp lit when Auto-tuning is activated (Orange)
		COM	Lights when controller response data (Green)
4	Keypad	SET SET	For parameter call-up and set value registration
		◀ SHIFT	Shift digits when changing settings
		▼ DOWN	Decrease numerals
		▲ UP	Increase numerals

FE300



1	PV	Indicating PV (measured value) and character information such as parameter codes or error codes (Red)	
2	SV	Indicating SV (target set value) or parameter values(Green)	
3	LED	OUT1	Lamp lit when OUT1 is activated (Orange)
		AL1	Lamp lit when Alarm 1 is activated (Red)
		AL2	Lamp lit when Alarm 2 is activated (Red)
		AT	Lamp lit when Auto-tuning is activated (Orange)
		COM	Lights when controller response data (Orange)
4	Keypad	SET SET	For parameter call-up and set value registration
		◀◀ SHIFT	Shift digits when changing settings
		∨ DOWN	Decrease numerals
		∧ UP	Increase numerals

External And Dimensions

FE250/251

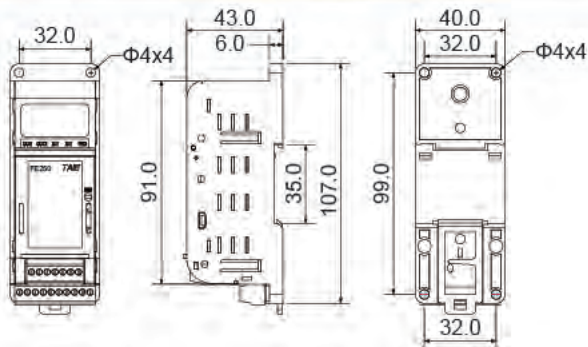



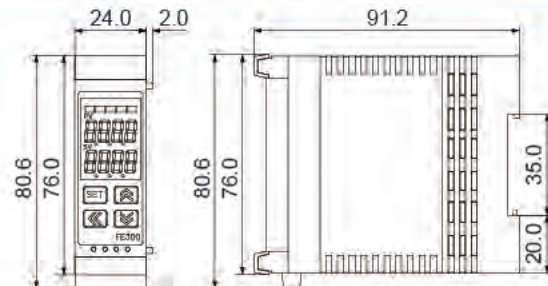





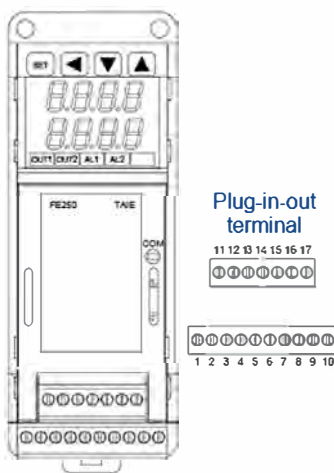

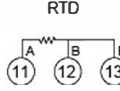
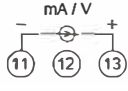







FE300



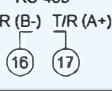







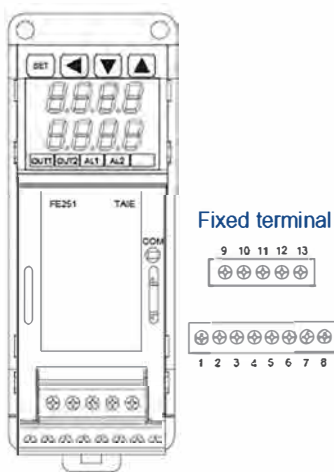

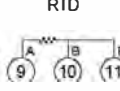
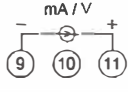







Terminal Arrangement



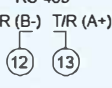







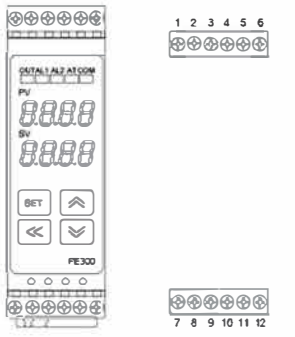







FE250

 <p>Plug-in-out terminal 11 12 13 14 15 16 17</p> <p>1 2 3 4 5 6 7 8 9 10</p>	Input	<p>TC / mV</p>  <p>RTD</p>  <p>mA / V</p> 	Power	<p>AC 85~265V</p>  <p>DC 24V</p>  
	Transmission	<p>mA / V</p> 	Alarm-1 Alarm-2	<p>AL1</p>  <p>AL2</p> 
	Remote SV/ CT Input	<p>mA / V</p>  <p>CT</p> 	Output-2	<p>Relay</p>  <p>SSR</p>  <p>mA / V</p> 
	Communication	<p>RS-485</p> <p>T/R (B-) T/R (A+)</p> 	Output-1	<p>Relay</p>  <p>SSR</p>  <p>mA / V</p> 

FE251

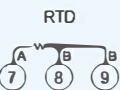
 <p>Fixed terminal 9 10 11 12 13</p> <p>1 2 3 4 5 6 7 8</p>	Input	<p>TC / mV</p>  <p>RTD</p>  <p>mA / V</p> 	Power	<p>AC 85~265V</p>  <p>DC 24V</p>  
	Transmission	<p>mA / V</p> 	Alarm-1 Alarm-2	<p>AL1</p>  <p>AL2</p> 
	Remote SV/ CT Input	<p>mA / V</p>  <p>CT</p> 	Output-2	<p>Relay</p>  <p>SSR</p>  <p>mA / V</p> 
	Communication	<p>RS-485</p> <p>T/R (B-) T/R (A+)</p> 	Output-1	<p>Relay</p>  <p>SSR</p>  <p>mA / V</p> 

FE300

 <p>Fixed terminal 1 2 3 4 5 6</p> <p>7 8 9 10 11 12</p>	Power	<p>AC 85~265V</p>  <p>DC 24V</p>  	Remote SV/ CT Input	<p>mA / V</p>  <p>CT</p> 
	Output	<p>Relay</p>  <p>SSR</p>  <p>mA / V</p> 	Communication	<p>RS-485</p> <p>T/R (B-) T/R (A+)</p>  <p>RS-485 (No Alarm)</p> <p>T/R (A+) T/R (B-)</p> 
	Transmission	<p>mA / V</p>  <p>mA / V (No Alarm)</p>  <p>mA / V (No Output)</p> 	Input	<p>TC / mV</p>  <p>RTD</p> 
	Alarm-1 Alarm-2	<p>AL1</p>  <p>AL2</p> 	Input	<p>mA / V</p> 

Specifications

Model		FE300	FE251	FE250
Terminal		Fixed terminal		Plug-in-out terminal
Supply Voltage		AC 85 ~ 265V, DC 24V (Optional Functions)		
Power Frequency		50/60 Hz		
Power Consumption		Approximately 6VA		
Memory		Non-Volatile Memory EEPROM		
Sensor Input ※ Please refer to Input Range Table		Accuracy : 0.1%		
		Sample time : 50ms		
		Thermocouple : (K, J, R, S, B, E, N, T, W, PLII, L)		
		RTD: PT100		
		DC Linear Analog Input: 0~20mA, 4~20mA 0~1V, 0~5V, 0~10V, 0~2V, 1~5V, 2~10V 0~25mV, 0~50mV, 0~70mV		
Output	OUT1 Relay	1a		1c
		1a SPST-NO, 250 VAC, 5A (resistive load), electrical life: 100,000 operations 1c SPDT-NO, 250 VAC, 5A (resistive load), electrical life: 50,000 operations SPDT-NC, 250 VAC, 2A (resistive load), electrical life: 20,000 operations		
	OUT2 Relay	-		1a
		SPST-NO, 250 VAC, 5A (resistive load), electrical life: 100,000 operations		
SSR Drive	ON: 24 V OFF: 0V max. load current: 20mA, with short circuit protection circuit			
linear	4~20mA, 0~20mA, 0~5V, 0~10V, 1~5V, 2~10V			
Control Method		ON-OFF or P, PI, PID control		
Alarm	Alarm 1	1a		1c
		1a SPST-NO, 250 VAC, 5A (resistive load), electrical life: 100,000 operations 1c SPDT-NO, 250 VAC, 5A (resistive load), electrical life: 50,000 operations SPDT-NC, 250 VAC, 2A (resistive load), electrical life: 20,000 operations		
	Alarm 2	1a SPST-NO, 250 VAC, 5A (resistive load), electrical life: 100,000 operations		
TRS	Re-transmitted Signal	4~20mA, 0~20mA, 0~5V, 0~10V, 1~5V, 2~10V		
	Source of Re-transmission	SV1, PV1, MV1, SV1R, PV1R, MV1R, SV2, PV2, MV2, SV2R, PV2R, MV2R		
	Accuracy	0.1%		
	Resolution	14 bit		
Remote SV	Signal	4~20mA, 0~20mA, 0~5V, 0~10V, 1~5V, 2~10V		
	Resolution	18 bit		
	Controlled by	SV		
Communication	Interface	RS-485 Half duplex Communication MAX. 31 units, MAX. distance 1200 meters		
	Protocol	Modbus RTU, TAIE		
	Parity bit	NONE, ODD, EVEN		
	Data bit	8 bit		
	Stop bit	1 or 2 bit		
	Baud rate	2400, 4800, 9600, 19200, 38400, 57600, 115200 bps		
Malfunction vibration		10~55 Hz 20m / s ² , for 10 mins. each in X, Y and Z directions.		
Vibration resistance		10~55 Hz 20m / s ² , for 2 hrs. each in X, Y and Z directions.		
Malfunction shock		100m / s ² , 3 times each in X, Y and Z directions.		
Shock resistance		300m / s ² , 3 times each in X, Y and Z directions.		
Operating environment Temperature/ Humidity		0 ~ 50°C (in the case of no freezing or condensation) / 20% ~ 90% RH		
Storage environment Temperature		-25 ~ 65°C (in the case of no freezing or condensation)		
Dimension (mm)		W26 x H81 x D90	W40 x H107 x D43	
Weight		Appox.90g	Appox.105g	

Oder Information

Block means optional functions with additional charge

	Output 1	Output 2	Alarm	TRS	Remote	COMM	Input type	Power
Model	1	0	1	0	0	0	01	A
Plug-in-out terminal FE250	0 None 1 Relay 2 Voltage Pulse (SSR Drive) 3 4-20mA	0 None 1 Relay 2 Voltage Pulse (SSR Drive) 3 4-20mA	0 None 1 1 Set 2 2 Sets A HBA B HBA+AL2	0 None 1 4-20mA 2 0-20mA A 0-5V B 0-10V C 1-5V D 2-10V	0 None 1 4-20mA 2 0-20mA A 0-5V B 0-10V C 1-5V D 2-10V	0 None 3 TTL B RS-485 (OLD FE) C RS-485	See input type table code	A AC 85-265V D DC 24V
Fixed terminal FE251 FE300	4 0-20mA A 0-5V B 0-10V C 1-5V D 2-10V	4 0-20mA A 0-5V B 0-10V C 1-5V D 2-10V						

Input Type Table

TYPE	Thermocouple														RTD		
	K		J		R	S	B	E	N	T	W	PLII	L	PT100			
Kind	K1	K2	J1	J2	R	S	B	E	N	T1	T2	W	PLII	L	PT1	PT2	PT3
Code	01	02	03	04	05	06	07	08	09	10	11	12	13	14	15	16	17
Range °C	600.0	1200	400.0	1200	1760	1760	1820	900	1300	400.0	400	2320	1200	800	850.0	850	850
	-50.0	-50	-50.0	-50	-50	-50	-50	-50	-50	-199.9	-199	-50	-50	-50	-199.9	-199	0

TYPE	LINEAR											
	AN1		AN2				AN3	AN4				
Code	18	19	20	21	22	23	24	25	26	27	28	29
Range	0-25mV	0-50mV	0-20mA	0-1V	0-2V	0-5V	0-10V	0-70mV	4-20mA	10-50mV	1-5V	2-10V
	4 kinds of choices: -1999-9999 -199.9-999.9 -19.99-99.99 -1.999-9.999											



- Before operating this product, read the instruction manual carefully to avoid incorrect operation.
- This product is intended for use with industrial machines, test and measuring equipment.
- It is not design for use with medical equipment.
- If it is possible that an accident may occur as a result of the failure of the product or some other abnormality, an appropriate independent protection device must be installed.

