

1 YEAR
WARRANTY



RoHS

Ω OMEGA™ User's Guide



DR-14P
Isolated signal converter
with universal power supply
for Process and Temperatures, DIN Rail Mount



omega.com info@omega.com

Omega Engineering, Inc:

800 Connecticut Ave. Suite 5N01, Norwalk, CT 06854, USA

Toll-Free: 1-800-826-6342 (USA & Canada only)

Customer Service: 1-800-622-2378 (USA & Canada only)

Engineering Service: 1-800-872-9436 (USA & Canada only)

Tel: (203) 359-1660

Fax: (203) 359-7700

e-mail: info@omega.com

SIGNAL CONVERTER DR-I4P

Signal converter for process and temperature signals, isolated, industrial applications

Isolated signal converter for process and temperature signals. Accepts a wide range of process signals including 4/20 mA, 0/10 Vdc, potentiometers and resistance measurements, providing excitation voltage to power the transducer when needed. Accepts a wide range of temperature signals, including Pt100, Pt500, Pt1000, thermocouples J, K, N, E, T, R, S, C and B, NTC sensors from 44004 to 44008 and from 44030 to 44034, and a configurable NTC range with configurable R_{25} and β parameters.

Configurable output in 4/20 mA (active or passive) or 0/10 Vdc. Universal power supply from 18 to 265 Vac/dc. 3 way isolation between input, output and power circuits. Circuit isolation prevents ground loops and transient propagation, protecting remote equipment and signal integrity.

Predefined configuration codes available for fast and easy configuration. Advanced configuration menu available to customize input and output signal ranges to specific values required. Configuration through front push-button keypad. Front information displays available for configuration and system information (input signal value, output signal value, configured label, signal percentage and process value).

Built-in 'force' functions to manually generate low and high output signals, to validate remote instrumentation during installation. 'SOS' mode to help on critical maintenance and repairs. Configurable power frequency rejection filter. 'Password' function to block non-authorized access to 'configuration menu'.

Designed for industrial use, with potential integration into a wide range of applications, reduced cost, excellent quality and available customization.

USER'S MANUAL

INDEX

1. How to order	2
2. Material included	2
3. Additional information	2
4. Installation and start-up	3
5. Typical applications	3
6. SOS mode	3
7. Messages	3
8. Predefined configuration codes	4
9. Connections and dimensions (mm (inch))	5
10. How to operate the instrument	6
10.1 Configuration system	6
10.2 'Normal mode' of operation	6
10.3 How to operate the 'Configuration menu'	6
10.4 How to operate the 'Force' menu	7
10.5 How to activate the 'Messages' function	7
10.6 Fast and advanced configurations	7
11. Input signals	8
11.1 Process	8
11.2 Potentiometers	8
11.3 Resistances	9
11.4 NTC sensors	9
11.5 Thermocouples	10
11.6 Pt100 sensors and other Pt	11
12. Technical specifications	13
13. Configuration menu	14
13.1 Function codes	14
13.2 Input range	14
13.3 Output range	15
13.4 Temperature configuration	16
13.5 Process configuration	16
13.6 Advanced scaling	18
13.7 Display information	19
13.8 Key 'UP' ('force' menu)	19
13.9 Key 'LE' ('messages' function)	20
13.10 'Tools' menu	20
14. Full configuration menu	22
15. Factory default parameters	24
16. Error codes	24
17. Precautions on installation	25
18. Warranty	25
19. CE declaration of conformity	25



When the marks 'Attention' or 'Risk of electrical shock' appear, read the documentation for information about the nature of the risk.

1. How to order

Reference	Description
DR-I4P	Signal converter

2. Material included

The instrument is provided with the following elements:

- 1 x instrument **DR-I4P**
- 4 x plug-in screw terminals
- 1 x quick installation guide

3. Additional information

To view the DR-I4P spec sheet and manuals visit us at [http://www.omega.com/...](http://www.omega.com/)

4. Installation and start-up



If this is the first time you are configuring the instrument, below are the steps to follow during a first installation. Read all the manual sections in order to have a full and clear view of the characteristics of the instrument. Do not forget to read the installation precautions at section 17.

1. Install the instrument at the DIN rail
2. Read how to operate the instrument (see section 10)
3. Connect the input, the output and the power terminals (see section 9).
4. Configure the input and output signals
 - choose a predefined configuration code (see section 8)
 - introduce the code at the instrument (see section 13.1)
5. If needed, customize the input and output signal ranges (see section 13.6)
6. If needed, configure the display reading (see section 13.7), the key 'UP' (▲) 'force' menu (see section 13.8), and the key 'LE' (◀) 'messages' function (see section 13.9).
7. If needed, block access to the 'configuration menu' (see section 13.10)

5. Typical applications

To measure process or temperature signals and provide a standard process signal in 4/20mA or 0/10Vdc. Accepts signals from standard thermocouples, Pt and Ntc sensors, potentiometers, resistances and process signals. Signal acquisition, linearization and transmission to remote acquisition devices. Isolation between circuits provided. Ranges can be scaled to the desired range.

6. SOS mode

The instrument includes a configurable 'SOS mode' function that provides a way to manually configure a fixed output signal. This output signal remains fixed, independent of the input signal value or sensor state.

This function allows to perform urgent maintenance or repair tasks at the input section of the system, for example replacing temperature probes or pressure transducers, while the instrument still provides a controlled signal that allows the process to continue its activity, under human surveillance. When the maintenance or repair task has been performed, the instrument can be taken back to the standard working mode, where the output signal is proportional to the input.

When manually activated, the 'SOS mode' generates the output signal configured, and the front display remains flashing with the message 'SoS'. All other systems are disabled, which means that :

- no error messages will be shown on display
- no key 'UP' (▲) 'fast access' menu is accessible
- no key 'LE' (◀) 'messages' function is accessible
- no 'Eco' mode activates

Only key 'SQ' (■) is accessible, to access the 'configuration menu' (eventually this access can be password locked) in order to deactivate the 'SOS mode'. Deactivation of 'SOS mode' must be performed manually by configuring the function to 'OFF'.

To configure the 'SOS mode' function, see section 13.10.

7. Messages

The instrument includes a configurable 'messages' function that provides advanced system information on the display, available to the operator with a single click at the front key 'LE' (◀).

This information is helpful during start-up, installation, system verification, routine maintenance and troubleshooting, as messages and values provide information on the actual input and output signal value, actual percentage of the input signal compared to the full scale and scaled process values.

This information is available at any time, and is displayed sequentially when requested (except while on 'SOS mode'). Access to this information reduces maintenance time, improves time invested in failure location, and helps for an easy resolution of the problem.

Additionally, each instrument can be assigned a custom label code of up to 8 characters (see Table 1), that can be displayed at the front display or at the messages sequence, making system identification of each instrument an easy task.

To configure the 'messages' function, see section 13.9.

Table 1 | Available label codes ('Label' parameter)

Letters		Numbers	Special
A	n	0	-
b	o	1	_
c	P	2	.
d	q	3	°
E	r	4	(blank)
F	S	5	
G	t	6	
h	u	7	
I	V	8	
J	W	9	
K	X		
L	Y		
M	Z		

Labeling examples ('Label' parameter): an application measures ambient temperature from a Pt100, burner temperature from a thermocouple J, and pressure from 4/20mA pressure transducer. All signals are converted to 4/20mA for retransmission to PLC or SCADA. Three DR-I4P converters are being used, to measure Pt100, thermocouple J and 4/20mA signals. Each DR-I4P can be configured the following label for easy identification :

- Label for ambient temperature : T_{Amb}.°C
- Label for burner temperature : T_{Bur}.°C
- Label pressure measurement: Prs.Bar

8. Predefined configuration codes

Select the desired code for your application, and check the following sections for more information:

- for information on how to activate a code, see section 13.1
- to customize the input and output signals, see section 13.6

Table 2 | Predefined configuration codes - Input / Output

Input Signal Range	Sensor	Output 4/20mA Code	Output 0/10Vdc Code	See section ...	
4/20 mA	Process	010	110	11.1	
0/10 Vdc		011	111		
0/100 %	Potentiometer	012	112	11.2	
0/100 %	Passive Pot.	013	113		
0/1 KOhm	Resistance	014	114	11.3	
0/10 KOhm		015	115		
0/100 KOhm		016	116		
0/1 MOhm		017	117		
Reserved		018 to 019	118 to 119		
-80/120 °C	Ntc 44004	020	120	11.4	
-80/120 °C	Ntc 44005	021	121		
-80/120 °C	Ntc 44006	022	122		
-80/120 °C	Ntc 44007	023	123		
-80/120 °C	Ntc 44008	024	124		
-80/75 °C	Ntc 44030	025	125		
-80/75 °C	Ntc 44031	026	126		
-80/75 °C	Ntc 44032	027	127		
-80/75 °C	Ntc 44033	028	128		
-80/75 °C	Ntc 44034	029	129		
-50/90 °C	Ntc $R_{25}=10K \beta=3500$	030	130		
-200/1200 °C	Thermocouple J	031	131		11.5
0/700 °C		032	132		
0/400 °C		033	133		
0/250 °C		034	134		
0/150 °C		035	135		
-200/1372 °C	Thermocouple K	036	136	11.5	
0/1200 °C		037	137		
0/700 °C		038	138		
0/400 °C		039	139		
0/300 °C		040	140		
0/250 °C		041	141		
0/150 °C		042	142		
Reserved			043 to 044		143 to 144
-200/1300 °C	Thermocouple N	045	145	11.5	
0/1200 °C		046	146		
0/1000 °C		047	147		
Reserved		048 to 049	148 to 149		

Table 2 | Predefined configuration codes - Input / Output

Input Signal Range	Sensor	Output 4/20mA Code	Output 0/10Vdc Code	See section ...
-200/1000 °C	Thermocouple E	050	150	11.5
0/1000 °C		051	151	
0/800 °C		052	152	
0/500 °C		053	153	
0/300 °C		054	154	
-200/400 °C	Thermocouple T	055	155	11.5
0/400 °C		056	156	
0/300 °C		057	157	
0/200 °C		058	158	
-50/1768 °C	Thermocouple R	059	159	11.5
0/1600 °C		060	160	
0/1000 °C		061	161	
-50/1768 °C	Thermocouple S	062	162	11.5
0/1600 °C		063	163	
0/2320 °C	Thermocouple C	064	164	11.5
0/1500 °C		065	165	
250/1820 °C	Thermocouple B	066	166	11.5
Reserved		067 to 069	167 to 169	
-200/850 °C	Pt100 (2 and 3 wires)	070	170	11.6
0/600 °C		071	171	
0/400 °C		072	172	
0/300 °C		073	173	
0/200 °C		074	174	
0/100 °C		075	175	
-50/+50 °C		076	176	
Reserved		077 to 079	177 to 179	
-200/850 °C	Pt500	080	180	11.6
-200/850 °C	Pt1000	081	181	
Reserved		082 to 099	182 to 199	
(End of list)		'----	(see notes below)	
(Custom selection)		'uSEr'	(see notes below)	

Notes

• Code 'uSEr' indicates that a user custom configuration is active, and it does not match any of the listed codes. This code is non-selectable, for information only.

Example: select code '011' for 0/10Vdc=4/20mA, the instrument reads code '011'. Later, configure the input to 0/7Vdc=4/20mA, this does not match a listed code, and the instrument reads 'uSEr'. Or change the output to 0/10Vdc=1/5Vdc, this does not match a listed code, and the instrument reads 'uSEr'.

• Code '----' identifies the end of the list, it follows code '199' and the list continues with code '010'. Select '----' to exit the list without applying changes.

9. Connections and dimensions (mm (inch))

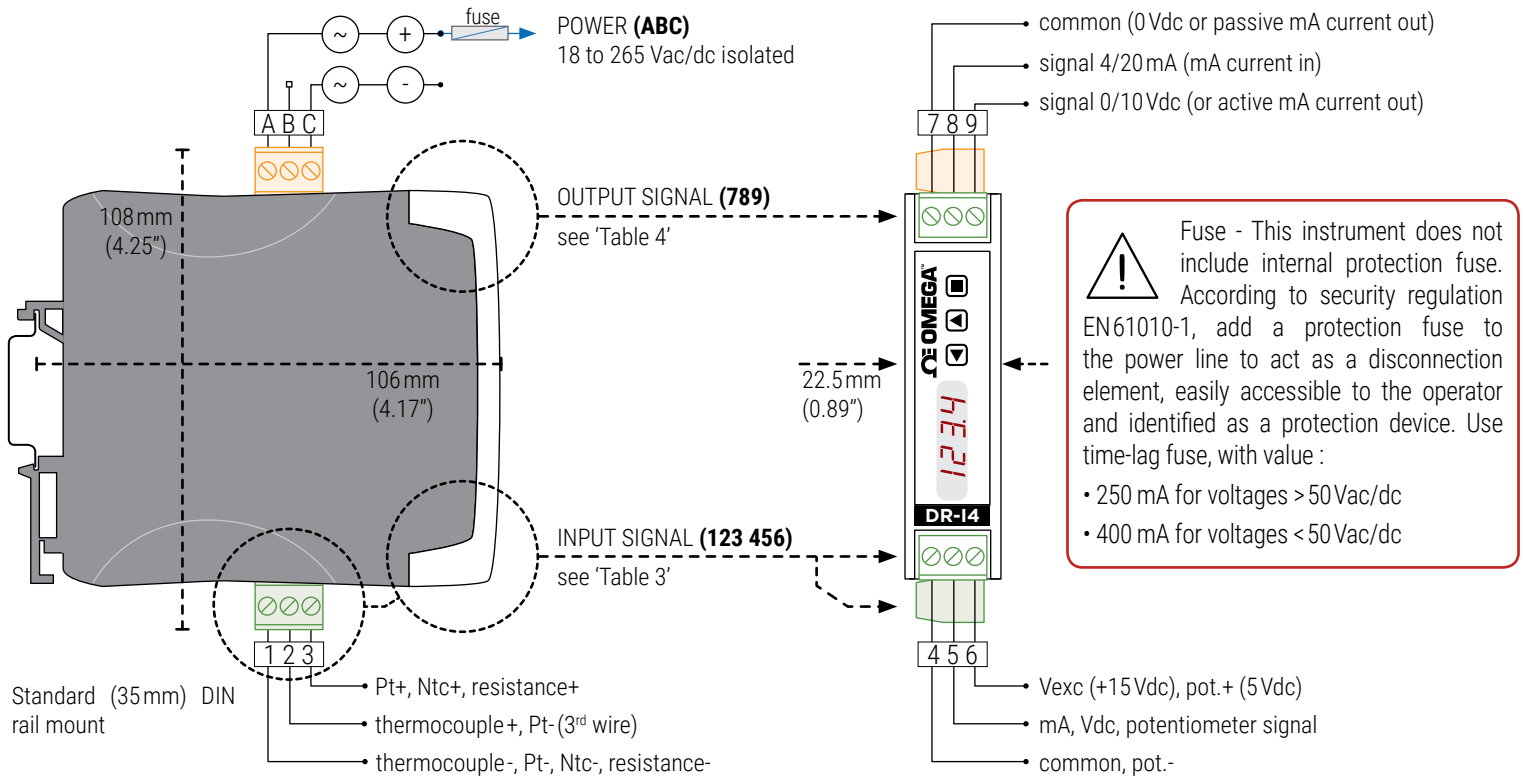

Table 3 | INPUT signal connections

INPUT signal	Input terminals						Section ...
	1	2	3	4	5	6	
4/20 mA (passive loop)					mA- (in)	+15 Vexc (out)	11.1
4/20 mA (active loop)				mA+ (out)	mA- (in)		11.1
0/10 Vdc (2 wires)				common	+Vdc		11.1
0/10 Vdc (3 wires)				common	+Vdc	+15 Vexc	11.1
Thermocouples	tc-	tc+					11.5
Ntc	ntc-		ntc+				11.4
Pt100 (3 wires)	pt100-	pt100- (3 rd wire)	pt100+				11.6
Pt100 (2 wires)	pt100-	short to terminal 1	pt100+				11.6
Pt500, Pt1000	pt-		pt+				11.6
Resistances	res-		res+				11.3
Potentiometer				pot-	signal	pot+ (+5 Vexc)	11.2
Passive potentiometer				common	signal	Vexc (in)	11.2

Table 4 | OUTPUT signal connections

OUTPUT signal	Output terminals			Connections
	7	8	9	
4/20 mA active output		mA- (in)	mA+ (out)	
4/20 mA passive output* (*external loop power needed)	mA+ (out)	mA- (in)		
0/10 Vdc	common		+Vdc	

10. How to operate the instrument

10.1 Configuration system

The instrument is fully configurable from the 3 push button keypad and the 4 red digit led display at the front of the instrument (see Table 5).

Table 5 | CONFIGURATION SYSTEM

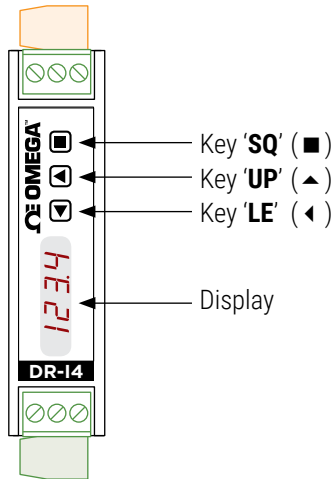

10.2 'Normal mode' of operation

AT POWER-UP

When the power supply is connected, the instrument applies the following sequence:

- the 'display' shows the firmware code 'b0.xx'.
- the 'display' shows the configured 'units' and 'input range' (for example: 'tc J' and '1200°').
- the instrument is now in 'normal mode' of operation and the 'display' shows the 'information' configured at section 13.7.

FROM 'NORMAL MODE' OF OPERATION

From 'normal mode' of operation, the operator can access the following functions:

- key 'SQ' (■) gives access to the 'configuration menu' (see section 10.3).
- key 'UP' (▲) gives access to the 'force' menu (see section 10.4).
- key 'LE' (◀) activates the 'messages' function (see section 10.5).

'ECO' FUNCTION ('DISPLAY' POWERED OFF)

The 'Eco' function powers off the display under the following conditions:

- the instrument is in 'normal mode' of operation.
- and there is no interaction from the operator for 60 seconds.

The decimal point remains active (flashing), indicating that the instrument is working correctly. This is a configurable function, enabled by default. To configure the 'Eco' function, see section 13.10.

Table 6 | 'ECO' DECIMAL POINT

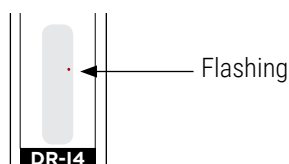

10.3 How to operate the 'Configuration menu'

HOW TO ENTER THE 'CONFIGURATION MENU'

With the instrument in 'normal mode' of operation (see section 10.2), press the 'SQ' (■) key and maintain for 1 second. The horizontal leds light from bottom to top. When the upper led lights, the instrument enters into the 'configuration menu'.

When entering the 'configuration menu', the first menu entry 'Function code' (codE) is displayed. See section 14 for a full view of the 'configuration menu'.



If the 'SQ' (■) key is released before entering into the 'configuration menu', the horizontal leds light downwards from top to bottom, and the instrument returns to 'normal mode' of operation.

HOW TO OPERATE INSIDE THE 'CONFIGURATION MENU'

Inside the 'configuration menu', use the front keypad to move through menu entries, parameters, and select configuration values:

- Key 'SQ' (■) functions as the 'ENTER' key. It selects the menu entry currently displayed. At numerical value entries, it validates the number displayed.
- Key 'UP' (▲) moves vertically through the different menu entries. At numerical value entries, it modifies the selected digit by increasing its value to 0, 1, 2, 3, 4, 5, 6, 7, 8, 9.
- Key 'LE' (◀) functions as the 'ESCAPE' key. It leaves the selected menu entry, and eventually, will leave the 'configuration menu'. When leaving the 'configuration menu', the changed parameters are activated. At numerical value entries, the 'LE' (◀) key allows to select the active digit. To modify a numeric value press the 'UP' (▲) key to increase the value '+1'. Press the 'SQ' (■) key to validate the value.

WHEN EXITING THE 'CONFIGURATION MENU'

When exiting the 'configuration menu' without changes (either by 'rollback' activation or because there are no changes in the configuration), the horizontal leds light down from top to bottom, and the instrument returns to 'normal mode' of operation.

When exiting the 'configuration menu' with changes, the display leds light a round shape while the new configuration is stored. When the round shape is finished, a start-up is applied (see section 10.2). After start-up, the new configuration is active and the instrument is in 'normal mode' of operation.

'ROLLBACK' FUNCTION

If there is no interaction from the operator for 60 seconds, the instrument exits the 'configuration menu' discarding changes, and returns to 'normal mode' of operation.



When the operator is inside the 'configuration menu', the output signal will remain overranged at maximum signal. Additional configurations are available at the 'On SQ' parameter (see section 13.10).



When the operator exits the 'configuration menu', the output signal is temporarily set to minimum value for a time <5seconds, while the instrument restarts.

10. How to operate the instrument (cont.)

10.4 How to operate the 'Force' menu

HOW TO ENTER THE 'FORCE' MENU

With the instrument in *'normal mode'* of operation (see section 10.2), press and hold the **'UP'** (▲) key for 1 second. The horizontal leds light from bottom to top. When the upper led lights, the instrument enters into the *'force'* menu.

If the **'UP'** (▲) key is released before entering into the *'force'* menu, the horizontal leds light downwards from top to bottom, and the instrument returns to *'normal mode'* of operation.

HOW TO OPERATE INSIDE THE 'FORCE' MENU

The available functions inside the *'force'* menu can be configured (see section 13.8). By default, *'Force High'*, *'Force Low'* and *'Force Set'* are available. Inside the *'force'* menu:

- press the **'UP'** (▲) key to move to the next function.
- press the **'SQ'** (■) key to activate the selected function.

When the function is active, the display will remain flashing. Press the **'SQ'** (■) key to deactivate the function (display stops flashing), or wait for the rollback to activate.

Table 7 | Example of 'Force' menu with all functions set to 'on'

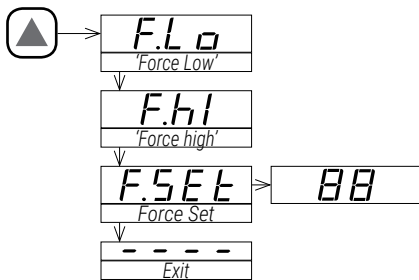

See section 13.8 for a list and a description of available functions.

DESCRIPTION OF 'FORCE' FUNCTIONS

The *'force'* functions allow to manually force the output signal to the low and high levels of the output signal selected. These functions allow to easily validate the correct function of remote elements connected to the instrument output, such as PLC, HMI's, SCADAs, etc.

The *'force low'* function sets the output signal to the minimum value of the selected range (4mA or 0Vdc or the value configured at the *'output_low'* parameter).

The *'force high'* function sets the output signal to the maximum value of the selected range (20mA or 10Vdc or the value configured at the *'output_high'* parameter).

The *'force set'* function sets the output signal to a value between 0 and 100% of the maximum selected range (4 to 20mA or 0 to 10Vdc or the range configured at the *'output_low'* and *'output_high'* parameters). When entering the *'force set'* function, the display reads '50' (the output is forced to 50% of the configured range). Use keys **'UP'** (▲) and **'LE'** (◀) to move up to 100% or down to 0% of the configured range.

HOW TO EXIT 'FORCE' MENU

To exit the *'force'* menu, press the **'LE'** (◀) key, or press the key **'UP'** (▲) key until the parameter '----' appears, and select by pressing the **'SQ'** (■) key, or wait without pressing any key until the automatic *'rollback'* activates.

When exiting the *'force'* menu, the horizontal leds light down from top to bottom, and the instrument returns to *'normal mode'* of operation.

'ROLLBACK' FUNCTION

If there is no interaction from the operator for 60 seconds, the instrument exits the *'force'* menu and returns to *'normal mode'* of operation.

10.5 How to activate the 'Messages' function

HOW TO ACTIVATE 'MESSAGES' FUNCTION

With the instrument in *'normal mode'* of operation (see section 10.2), press the **'LE'** (◀) key to activate the *'messages'* function. The *'messages'* function displays information about the instrument status. The information available is configurable (see section 13.9).

The *'messages'* function ends when all the information has been displayed or front keys **'UP'** (▲) or **'SQ'** (■) are pressed. The *'display'* returns to *'normal mode'* of operation.

10.6 Fast and advanced configurations

FAST CONFIGURATION

The fastest way to configure the instrument is to activate one of the predefined configuration codes (see section 8).

Access the *'configuration menu'* and enter the **'Function code'** (codE) menu entry. The code displayed is the current active input-output range. Select the new code and validate. Selecting a code automatically exits the *'configuration menu'* and activates the new configuration.



*There are different codes for 4/20mA and 0/10Vdc output signals.

To customize the input and output signals, see the *'Advanced scaling'* section of the *'configuration menu'* (see section 13.6).

ADVANCED CONFIGURATION

Additional configuration parameters are available at the *'configuration menu'*. The operator can customize the input and output signal ranges, the messages seen on display, the functions available at the *'force'* menu, the messages associated to the **'LE'** (◀) key, activate filters, password function, etc.

See section 13 for a detailed explanation on the *'configuration menu'*.

11. Input signals

11.1 Process



MEASURING 4/20 mA AND 0/10 Vdc PROCESS SIGNALS

The instrument can be configured to measure 4/20 mA (active and passive) and 0/10 Vdc process signals. The instrument provides excitation voltage to power-up the transducer when necessary. See connections at 'Table 8'.

For bipolar ± 20 mA and ± 10 Vdc process signals, see our instrument **I4E**.

PREDEFINED CONFIGURATION CODES

See 'Table 9' for a list of predefined input-output configuration codes. To activate a code see section 13.1.

CUSTOMIZED SIGNAL RANGES

To customize the input and/or output signal ranges, access the 'Advanced scaling' menu (see section 13.6).

MAXIMUM OVERSIGNAL AND PROTECTIONS

'Maximum oversignal' is the maximum signal accepted by the instrument. Higher signal values may damage the instrument. Lower signal values are non destructive but may be out of accuracy specifications. The input is protected against inverted connections.

The milliampere input is protected against over currents: the instrument automatically opens the loop for currents >40 mA (approx.). Error 13 is displayed (see section 16). The instrument tries to reconnect every 1 second.

EXCITATION VOLTAGE (VEXC)

The instrument provides +15 Vdc excitation voltage at terminal '6'. This excitation voltage is provided to power up the transducer that generates the signal, up to a maximum of 30 mA.

OUTPUT SIGNAL

The output signal is configurable to 4/20 mA (active and passive) and 0/10 Vdc.

Table 8 | Connection examples for process signals

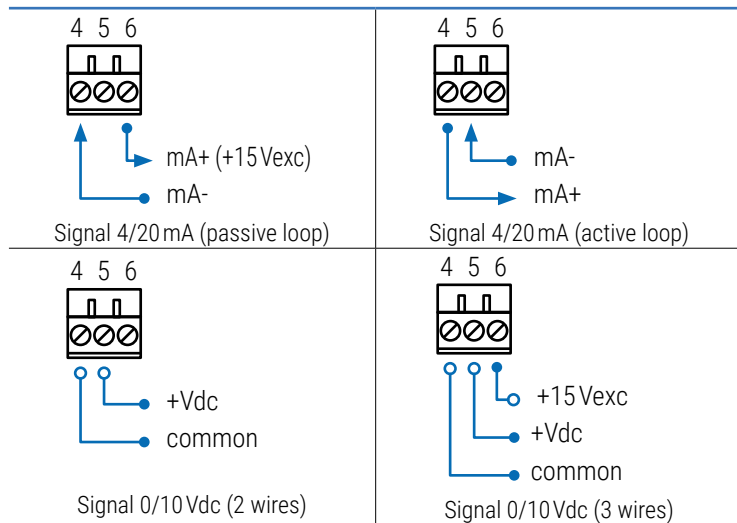

Table 9 | Input signal ranges for process signals

Input range	Code for 4/20 mA output	Code for 0/10 Vdc output	Accuracy (%FS)	Max. oversignal	Zin
4/20 mA	010	110	<0.10%	1 Adc	$V^* < 2V$
0/10 Vdc	011	111	<0.10%	50 Vdc	1 MOhm

* Voltage drop on terminals <2 Vdc.

11.2 Potentiometers



MEASURING POTENTIOMETERS

The instrument can be configured to measure potentiometer signals (3 wires), from potentiometers with nominal value between 250 Ohms and 15 KOhms. See connections at 'Table 10'.

The instrument can also be connected to existing potentiometer measuring circuits, and provide a parallel measure without affecting the existing measurement circuit ('passive mode'). Circuits with excitation voltage to the potentiometer from 5 Vdc to 20 Vdc are accepted. In this 'passive mode', the excitation voltage is not provided, but measured from the existing circuit. See connections at 'Table 10'.

PREDEFINED CONFIGURATION CODES

See 'Table 11' and 'Table 12' for a list of predefined input-output configuration codes. To activate a code see section 13.1.

CUSTOMIZED SIGNAL RANGES

To customize the input and/or output signal ranges, access the 'Advanced scaling' menu (see section 13.6).

EXCITATION VOLTAGE (VEXC)

The instrument provides +5 Vdc excitation voltage at terminal '6'.

In passive mode, external Vexc can be measured up to 20 Vdc. Higher values can be destructive.

OUTPUT SIGNAL

The output signal is configurable to 4/20 mA (active and passive) and 0/10 Vdc.

Table 10 | Connection examples for potentiometer signals

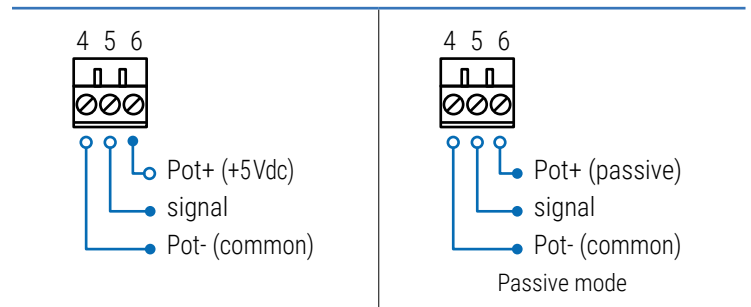

Table 11 | Input signal ranges for potentiometer signals

Input range	Code for 4/20 mA output	Code for 0/10 Vdc output	Accuracy (%FS)	Max. oversignal
0/100%	012	112	<0.20%	---

Table 12 | Input signal ranges for 'passive mode' potentiometer signals

Input range	Code for 4/20 mA output	Code for 0/10 Vdc output	Accuracy (%FS)	Max. overvoltage on passive Vexc
0/100%	013	113	<0.20%	20 Vdc

11. Input signals (cont.)

11.3 Resistances



MEASURING RESISTANCES

The instrument can be configured to measure resistance signals with ranges from 1Kohm up to 1MOhm. Measurement uses 2 wires. See connections at 'Table 13'.

PREDEFINED CONFIGURATION CODES

See 'Table 14' for a list of predefined input-output configuration codes. To activate a code see section 13.1.

CUSTOMIZED SIGNAL RANGES

To customize the input and/or output signal ranges, access the 'Advanced scaling' menu (see section 13.6).

SENSOR BREAK DETECTION

The instrument detects the sensor break and displays an error message (see section 16).

CURRENT THROUGH THE SENSOR

The instrument generates a fixed current to measure the resistance values.

MAXIMUM OVERSIGNAL AND PROTECTIONS

Active signals are not to be connected to the resistance input terminals. Maximum active input is 3Vdc. Higher voltage inputs will be internally shorted and can be destructive.

OUTPUT SIGNAL

The output signal is configurable to 4/20mA (active and passive) and 0/10Vdc.

Table 13 | Connection examples for resistance signals

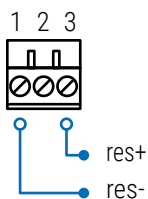
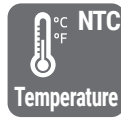

Table 14 | Input signal ranges for resistances

Input range	Code for 4/20mA output	Code for 0/10Vdc output	Accuracy (%FS)	Current on resistance	Max. overvoltage
0/1 KOhm	014	114	<0.20%	167 uA	3 Vdc
0/10 KOhm	015	115	<0.20%	45 uA	3 Vdc
0/100 KOhm	016	116	<0.20%	4.5 uA	3 Vdc
0/1000 KOhm	017	117	<0.50%	1 uA	3 Vdc

11.4 NTC sensors



MEASURING NTC SENSORS

The instrument can be configured to measure temperature from common NTC sensors. Accepts standard NTC models 44004, 44005, 44006, 44007, 44008, 44030, 44031, 44032, 44033 and 44034. See connections at 'Table 15'.

An independent range exists for NTC sensors characterized by its R_{25} and β parameters. Configurable R_{25} values from 1.0KOhm to 200.0KOhm, and β values from 2500 to 5500. This type of NTC can read signals down to 0 Ohms and up to 16MOhms.

PREDEFINED CONFIGURATION CODES

See 'Table 16' for a list of predefined input-output configuration codes. To activate a code see section 13.1.

CUSTOMIZED SIGNAL RANGES

To customize the input and/or output signal ranges, access the 'Advanced scaling' menu (see section 13.6).

SENSOR BREAK DETECTION

The instrument detects the sensor break and displays an error message (see section 16).

CURRENT THROUGH THE SENSOR

The instrument generates a maximum of 167 uA through the NTC sensors, with a power dissipation of <10 uW.

OUTPUT SIGNAL

The output signal is configurable to 4/20mA (active and passive) and 0/10Vdc.

Table 15 | Connection examples for NTC signals

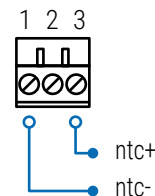

Table 16 | Input signal ranges for NTC sensors

Sensor	Measurement range	Code for 4/20mA output	Code for 0/10Vdc output	Accuracy (%FS)
NTC 44004	-80/120 °C -112/248 °F	020	120	<0.30%
NTC 44005	-80/120 °C -112/248 °F	021	121	<0.25%
NTC 44006	-80/120 °C -112/248 °F	022	122	<0.10%
NTC 44007	-80/120 °C -112/248 °F	023	123	<0.15%
NTC 44008	-80/120 °C -112/248 °F	024	124	<0.20%*
NTC 44030	-80/75 °C -112/167 °F	025	125	<0.10%
NTC 44031	-80/75 °C -112/167 °F	026	126	<0.10%
NTC 44032	-80/75 °C -112/167 °F	027	127	<0.20%*
NTC 44033	-80/75 °C -112/167 °F	028	128	<0.10%
Ntc 44034	-80/75 °C -112/167 °F	029	129	<0.10%
Ntc $R_{25}=10K, \beta=3500$	-50/90 °C -58/194 °F	030	130	<0.20%

* For indicated sensors, from -60°C down to -80°C, accuracy is <0.8%

11. Input signals (cont.)

11.5 Thermocouples

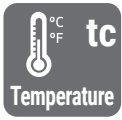

MEASURING THERMOCOUPLES

The instrument can be configured to measure temperature from thermocouple sensors J, K, N, E, T, R, S, C and B. The instrument automatically compensates the thermocouple cold junction. All signals according to ITS90. See connections at 'Table 17'.

PREDEFINED CONFIGURATION CODES

See 'Table 18' to 'Table 26' for a list of predefined input-output configuration codes. To activate a code see section 13.1.

CUSTOMIZED SIGNAL RANGES

To customize the input and/or output signal ranges, access the 'Advanced scaling' menu (see section 13.6).

SENSOR BREAK DETECTION AND SHORT CIRCUIT DETECTION

The instrument detects the sensor break or short circuit error at the input signals, and displays an error message (see section 16).

MAXIMUM OVERSIGNAL

Maximum oversignal for thermocouple inputs is 1Vdc. Higher voltage inputs can be destructive.

TOTAL ERROR

The 'total error' is expressed as the measurement error (% of full scale) plus the cold junction error (indicated as $\pm 2^\circ\text{C}$), and is valid for mA output. For Vdc output, see section 12.

OUTPUT SIGNAL

The output signal is configurable to 4/20mA (active and passive) and 0/10Vdc.

Table 17 | Connection examples for thermocouples

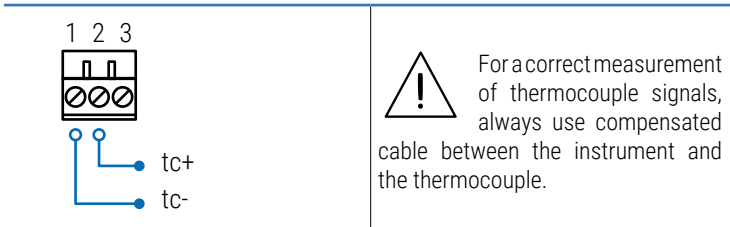

Table 18 | Temperature ranges for thermocouple J

Input signal	Code for 4/20mA output	Code for 0/10Vdc output	Measurement range		Total error
Thermoc. J	031	131	-200/1200 °C	-328/2192 °F	<0.15% FS $\pm 2^\circ\text{C}$
	032	132	0/700 °C	32/1292 °F	<0.20% FS $\pm 2^\circ\text{C}$
	033	133	0/400 °C	32/752 °F	<0.10% FS $\pm 2^\circ\text{C}$
	034	134	0/250 °C	32/482 °F	<0.15% FS $\pm 2^\circ\text{C}$
	035	135	0/150 °C	32/302 °F	<0.20% FS $\pm 2^\circ\text{C}$

Table 19 | Temperature ranges for thermocouple K

Input signal	Code for 4/20mA output	Code for 0/10Vdc output	Measurement range		Total error
Thermoc. K	036	136	-200/1372 °C	-328/2501 °F	<0.15% FS $\pm 2^\circ\text{C}$
	037	137	0/1200 °C	32/2192 °F	<0.15% FS $\pm 2^\circ\text{C}$
	038	138	0/700 °C	32/1292 °F	<0.20% FS $\pm 2^\circ\text{C}$
	039	139	0/400 °C	32/752 °F	<0.30% FS $\pm 2^\circ\text{C}$
	040	140	0/300 °C	32/572 °F	<0.40% FS $\pm 2^\circ\text{C}$
	041	141	0/250 °C	32/482 °F	<0.40% FS $\pm 2^\circ\text{C}$
	042	142	0/150 °C	32/302 °F	<0.70% FS $\pm 2^\circ\text{C}$

Table 20 | Temperature ranges for thermocouple N

Input signal	Code for 4/20mA output	Code for 0/10Vdc output	Measurement range		Total error
Thermoc. N	045	145	-200/1300 °C	-328/2372 °F	<0.15% FS $\pm 2^\circ\text{C}$
	046	146	0/1200 °C	32/2192 °F	<0.15% FS $\pm 2^\circ\text{C}$
	047	147	0/1000 °C	32/1832 °F	<0.15% FS $\pm 2^\circ\text{C}$

Table 21 | Temperature ranges for thermocouple E

Input signal	Code for 4/20mA output	Code for 0/10Vdc output	Measurement range		Total error
Thermoc. E	050	150	-200/1000 °C	-328/1832 °F	<0.15% FS $\pm 2^\circ\text{C}$
	051	151	0/1000 °C	32/1832 °F	<0.15% FS $\pm 2^\circ\text{C}$
	052	152	0/800 °C	32/1472 °F	<0.15% FS $\pm 2^\circ\text{C}$
	053	153	0/500 °C	32/932 °F	<0.15% FS $\pm 2^\circ\text{C}$
	054	154	0/300 °C	32/572 °F	<0.15% FS $\pm 2^\circ\text{C}$

Table 22 | Temperature ranges for thermocouple T

Input signal	Code for 4/20mA output	Code for 0/10Vdc output	Measurement range		Total error
Thermoc. T	055	155	-200/400 °C	-328/752 °F	<0.15% FS $\pm 2^\circ\text{C}$
	056	156	0/400 °C	32/752 °F	<0.15% FS $\pm 2^\circ\text{C}$
	057	157	0/300 °C	32/572 °F	<0.15% FS $\pm 2^\circ\text{C}$
	058	158	0/200 °C	32/392 °F	<0.15% FS $\pm 2^\circ\text{C}$

Table 23 | Temperature ranges for thermocouple R

Input signal	Code for 4/20mA output	Code for 0/10Vdc output	Measurement range		Total error
Thermoc. R	059	159	-50/1768 °C	-58/3214 °F	<0.15% FS $\pm 2^\circ\text{C}$
	060	160	0/1600 °C	32/2912 °F	<0.15% FS $\pm 2^\circ\text{C}$
	061	161	0/1000 °C	32/1832 °F	<0.15% FS $\pm 2^\circ\text{C}$

Table 24 | Temperature ranges for thermocouple S

Input signal	Code for 4/20mA output	Code for 0/10Vdc output	Measurement range		Total error
Thermoc. S	062	062	-50/1768 °C	-58/3214 °F	<0.15% FS $\pm 2^\circ\text{C}$
	063	063	0/1600 °C	32/2912 °F	<0.15% FS $\pm 2^\circ\text{C}$

Table 25 | Temperature ranges for thermocouple C

Input signal	Code for 4/20mA output	Code for 0/10Vdc output	Measurement range		Total error
Thermoc. C	064	164	0/2320 °C	32/4208 °F	<0.15% FS $\pm 2^\circ\text{C}$
	065	165	0/1500 °C	32/2732 °F	<0.15% FS $\pm 2^\circ\text{C}$

Table 26 | Temperature ranges for thermocouple B

Input signal	Code for 4/20mA output	Code for 0/10Vdc output	Measurement range		Total error
Thermoc. B	066	166	250/1820 °C	482/3308 °F	<0.40% FS $\pm 2^\circ\text{C}$

11. Input signals (cont.)

11.6 Pt100 sensors and other Pt



MEASURING PT TEMPERATURE SENSORS

The instrument can be configured to measure temperature from Pt100, Pt500 and Pt1000 sensors. See connections at 'Table 27'.

PREDEFINED CONFIGURATION CODES

See 'Table 28' and 'Table 29' for a list of predefined input-output configuration codes. To activate a code see section 13.1.

CUSTOMIZED SIGNAL RANGES

To customize the input and/or output signal ranges, access the 'Advanced scaling' menu (see section 13.6).

SENSOR BREAK DETECTION AND SHORT CIRCUIT DETECTION

The instrument detects the sensor break or short circuit error at the input signals, and displays an error message (see section 16).

PT100 WITH 2 AND 3 WIRES

The instrument accepts 2 and 3 wire Pt100 sensor. When using 3 wires, the instrument applies automatic compensation of the cable resistance up to 150hms. All three terminals must be connected (see Table 27).

'ALPHA' TEMPERATURE COEFFICIENT

The instrument is configured by default, to work with an 'alpha' value of '0.0385' for Pt sensors (Pt100, Pt500, Pt1000). To activate an 'alpha' value of '0.0390' see section '13.4'. This parameter is associated to the sensor and depends on the sensor manufacturer.

CURRENT THROUGH THE SENSOR

The instrument generates 960uA through Pt100 sensors, <170uA through Pt500, and <120uA through Pt1000 sensors.

OUTPUT SIGNAL

The output signal is configurable to 4/20mA (active and passive) and 0/10Vdc.

Table 28 | Temperature ranges for Pt100

Input signal	Code for 4/20mA output	Code for 0/10Vdc output	Measurement range		Total error (error en °C)
			°C	°F	
Pt100	070	170	-200/850	-328/1562	<0.25% FS (<2.6°C)
	071	171	0/600	32/1112	<0.25% FS (<1.5°C)
	072	172	0/400	32/752	<0.30% FS (<1.2°C)
	073	173	0/300	32/572	<0.25% FS (<0.8°C)
	074	174	0/200	32/392	<0.30% FS (<0.6°C)
	075	175	0/100	32/212	<0.50% FS (<0.5°C)
	076	176	-50/+50	-58/122	<0.50% FS (<0.5°C)

Table 29 | Temperature ranges for Pt500 and Pt1000

Input signal	Code for 4/20mA output	Code for 0/10Vdc output	Measurement range		Total error
			°C	°F	
Pt500	080	180	-200/850	-328/1562	<0.20% FS
Pt1000	081	181	-200/850	-328/1562	<0.20% FS

Table 27 | Connection examples for Pt100 (2 and 3 wires) and Pt500, Pt1000

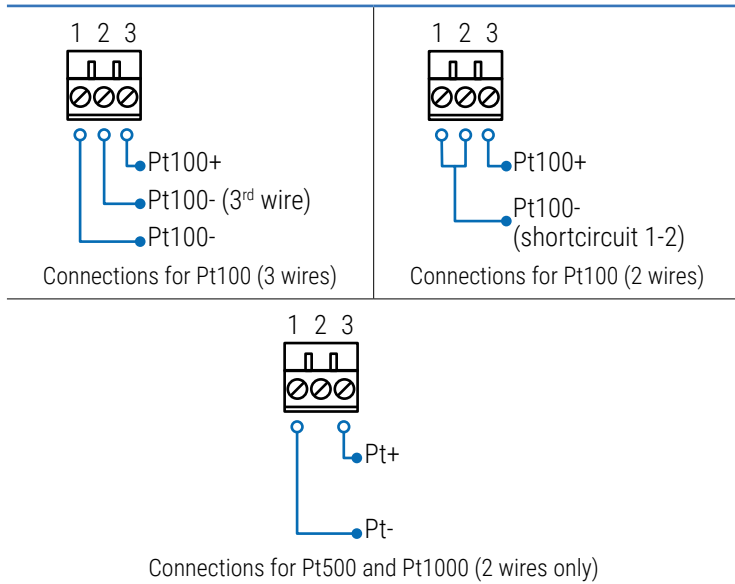

This page blank

12. Technical specifications

INPUT SIGNAL RANGES

process	4/20 mA, 0/10 Vdc (active and passive) excitation voltage +15 Vdc @25mA (see section 11.1)
thermocouples	J, K, N, E, T, R, S, C and B conforming to ITS-90 (see section 11.5)
'Pt' sensors	Pt100 (2 wires and 3 wires) Pt500, Pt1000 (2 wires) (see section 11.6)
'NTC' sensors	(see section 11.4)
resistances	ranges from 0/1 Kohm up to 0/1 MOhm (see section 11.3)
potentiometers	nominal value from 250 Ohm to 15 KOhm (see section 11.2)

ACCURACY AT 25 °C

	see for each type of signal at section 11 <i>*accuracy values are indicated for 4/20mA output. For 0/10Vdc output, add +0.05% to indicated accuracy values.</i>
--	--

THERMAL DRIFT

	±100 ppm/°C (F.S.)
	±0.05 °C/°C (thermocouple cold junction)

STEP RESPONSE

	Step response associated to the configured power filter (see section 13.10). Typical response values to reach 99% of the output signal, as a response to a 100% step at the signal input (see Table 30).
--	--

OUTPUT SIGNAL RANGES

active current output	4/20 mA active max. <22 mA, min. 0 mA maximum load <400 Ohm
passive current output	4/20 mA passive max. 30 Vdc on terminals
voltage output	0/10 Vdc, max. <11 Vdc, min. -0.05 Vdc (typ.) minimum load >10 KOhm

CONFIGURATION SYSTEM

key pad + display	accessible at the front of the instrument
configuration	'configuration menu' and 'predefined codes'
scalable units	scalable input ranges scalable output ranges scalable process display

POWER SUPPLY

voltage range	18 to 265 Vac/dc isolated (20 to 240 Vac/dc ±10%)
AC frequency	45 to 65 Hz
consumption	<3.0 W
power wires	1 mm ² to 2.5 mm ² (AWG17 to AWG14)
overvoltage category	2

ISOLATION

input - output	3000 Veff (60 seconds)
power - input	3000 Veff (60 seconds)
power - output	3000 Veff (60 seconds)

Table 30 | Response times

Signal type	No filter	50Hz or 60Hz filter	Both
Process	<60 mSec.	<250 mSec.	<600 mSec.
Pt100	<100 mSec.	<320 mSec.	<2 Sec.
Thermocouple	<100 mSec.	<200 mSec.	<1 Sec.
Resistances*	<100 mSec.	<200 mSec.	<200 mSec.

**For a 1 MOhm range, the response time is doubled.*

ENVIRONMENTAL

IP protection	IP30
impact protection	IK06
operation temperature	from 0 to +50 °C
storage temperature	from -20 to +70 °C
'warm-up' time	15 minutes
humidity	0 to 95% non condensing
altitude	up to 2000 meters

MECHANICAL

size	106 x 108 x 22.5 mm
mounting	standard DIN rail (35 x 7.5 mm)
connections	plug-in screw terminal (pitch 5.08 mm)
housing material	polyamide V0
weight	<150 grams
packaging	120 x 115 x 30 mm, cardboard

13. Configuration menu

13.1 Function codes

The fastest way to configure the instrument, is to select a predefined configuration code (see section 8). At the **'Configuration code' (codE)** parameter use keys **'UP' (▲)** and **'LE' (◀)** to move up and down through the list of codes. Locate the desired code, and press **'SQ' (■)**. The instrument shows the **'codE'** parameter. Press **'LE' (◀)** to exit the *'configuration menu'*. The instrument stores the new configuration, applies a *'power-up'* routine and returns to the *'normal mode'* of operation (see section 10.2).

Selecting a *'reserved'* code or *'----* returns to the previous menu without changes.

When entering the **'Function code' (codE)** parameter, the active *'configuration code'* is displayed. If the actual configuration does not match any of the configuration codes, code **'uSEr'** is displayed.

There are different codes for 4/20mA output (codes from 010 to 099) and 0/10Vdc output (codes from 110 to 199) (see section 8).

Custom input and output signal ranges can be configured at the *'Advanced scaling'* section of the *'configuration menu'* (see section 13.6).

13.2 Input range

At the **'Input signal' (InP)** menu entry, select the input signal to be measured. The different input signals available are grouped by process, thermocouples, pt sensors, ntc sensors, resistances and potentiometers. Only one input signal can be selected.

 If you have already selected a configuration code (see section 13.1), the input signal has been already selected and there is no need to manually select the **'Input range' (InP)** parameter again.

At the **'Process' (Proc)** parameter select **'420'** for 4/20 mA or **'010'** for 0/10Vdc signal input.

At the **'Thermocouples' (tc)** parameter select from the available thermocouples J, K, N, E, T, R, S, C or B.

At the **'Pt sensors' (Pt)** parameter select from the available pt sensors Pt100 (2 wires or 3 wires), Pt500 or Pt1000. For 2 and 3 wires Pt100 sensors, see section 11.6 for differences on connection for each case.

At the **'Ntc sensors 1' (ntc.1)** parameter select from the available Ntc sensors. The decimal point at the beginning indicates that part of ntc name is missing. For example, the **'Ntc 44004'** is designated with **'.4004'** as the first number '4' is missing. The same applies to Ntc sensors 44004 to 44009 and 44030 to 44034. For non-standard Ntc sensors, characterized for R_{25} and β parameters, see the **'Ntc sensors 2' (ntc.2)** parameter below.

At the **'Ntc sensors 2' (ntc.2)** configure the input to read from an ntc sensor, characterized by the R_{25} and β parameters. At the **'Ntc R_{25} ' (r.25)** parameter configure the resistance at 25degrees of the ntc sensor, in KOhms, with accepted values from 1.0KOhms and 200.0KOhms. At the **'Ntc β ' (BEtA)** parameter configure the value fo the ' β ' parameter of the ntc sensor, with accepted values between 2000 and 5500.

At the **'Resistances' (rES)** parameter select from the available resistance ranges.

At the **'Potentiometer' (Pot)** parameter select to activate the potentiometer mode.

At the **'Passive Potentiometer' (Pot.P)** parameter select to activate the passive potentiometer mode. See section 11.2 for an explanation of differences between potentiometer and passive potentiometer measure.

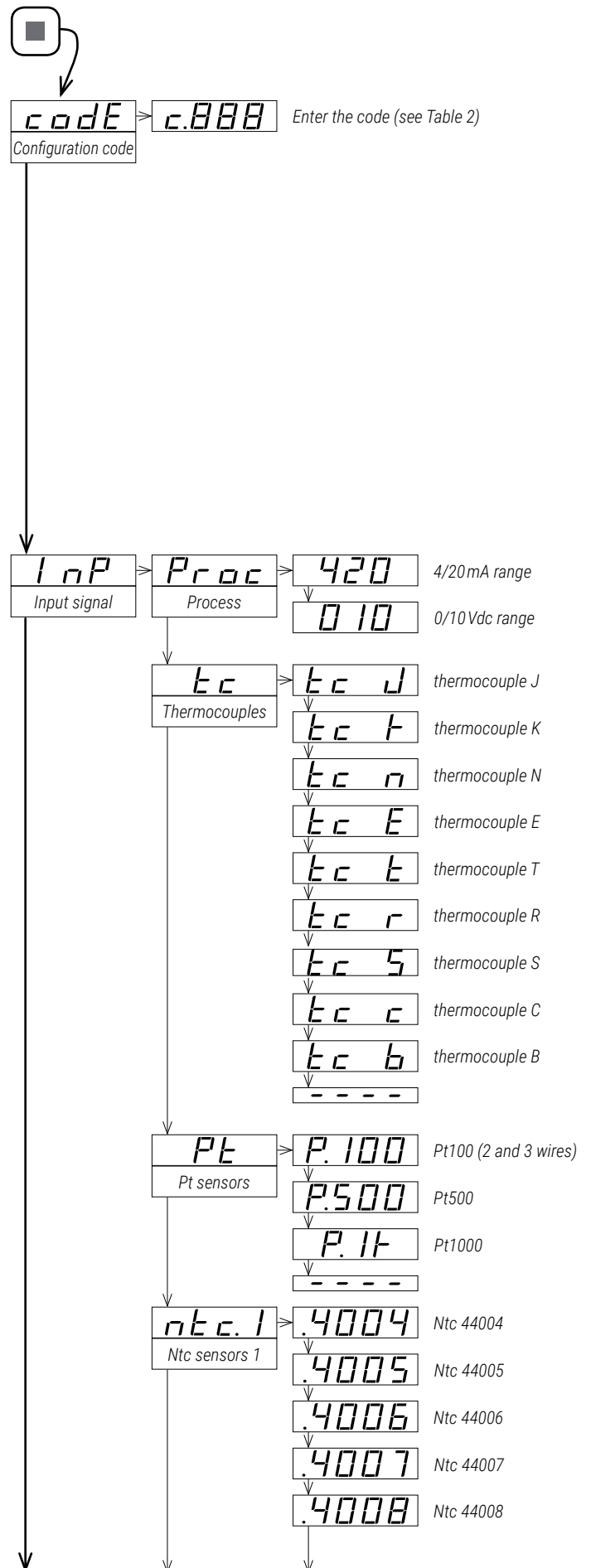

13. Configuration menu (cont.)

Input signal ranges are also accessible as predefined 'configuration codes' (see section 8). The predefined 'configuration codes' include some additional input-output ranges that are not available at the 'Input range' (InP) list of ranges.

- example: select the '0/1500°C' input range for thermocouple J '0/1500°C=4/20mA' or '0/1500°C=0/10Vdc' configuration. To customize to a smaller range (for example 0/1250°C) see section 13.6. To manually select the output signal see section 13.3. To customize the output range for a smaller range (for example 0/1500°C=8/12mA or 0/1500°C=1/5Vdc) see section 13.6.

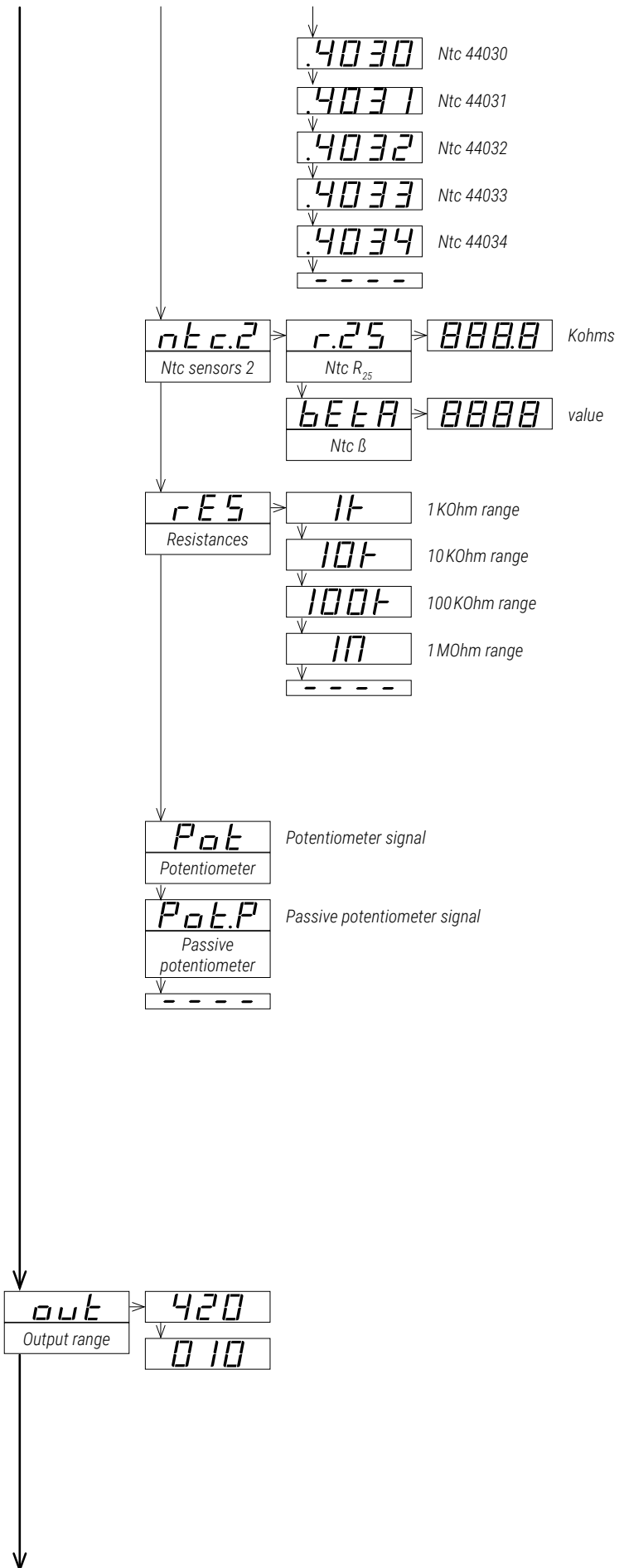

13.3 Output range

At the 'Output range' (out) menu entry, select the output signal range to 4/20mA (value '420') or to 0/10Vdc (value '010').

The output signal range selected can be later customized to operate in a reduced range of signal (see section 13.6).

13. Configuration menu (cont.)

13.4 Temperature configuration

At the **'Temperature configuration' (t.cnF)** menu, configure parameters associated with the measure of temperature sensors (Pt sensors, thermocouples and Ntc).

- at the **'Temperature units' (dEG)** parameter select the temperature units of the temperature. Values available are **'Degrees celsius' (°C)** or **'Degrees fahrenheit' (°F)**. The value of the input signal, when indicated on display, will be scaled as °C or °F. All ranges expressed without decimals, except Pt and NTC sensors, expressed with 1 decimal.
- at the **'Offset' (oFFS)** parameter configure the number of degrees to add to the measurement. Values accepted are from -199.9 up to 999.9 (°C). This is an offset parameter, and applies to the measured temperature value. It affects the output signal generated by the instrument, the display value when indicating the *'input signal value'* and the *'messages'* function when indicating the *'input signal value'*. Changing the **'Temperature units' (dEG)** parameter from °C to °F does not change the *'offset'* numerical value, which is always expressed in the °C. This parameter applies to all temperature sensors (thermocouples, Pt sensors, Ntc sensors) and does not apply to process signals.
- at the **'Cold junction' (t.cJc)** parameter configure if the cold junction of the thermocouple is compensated by the instrument (**on**, default option) or the compensation is disabled (**oFF**). This parameter applies only to thermocouple sensors.
- at the **'Pt alpha' (ALPh)** parameter select **'385'** if your Pt sensor has a temperature coefficient of 0.00385°C, or select **'390'** if your Pt sensor has a temperature coefficient of 0.00390°C. This parameter applies only to Pt sensors (Pt100, Pt500, Pt1000).

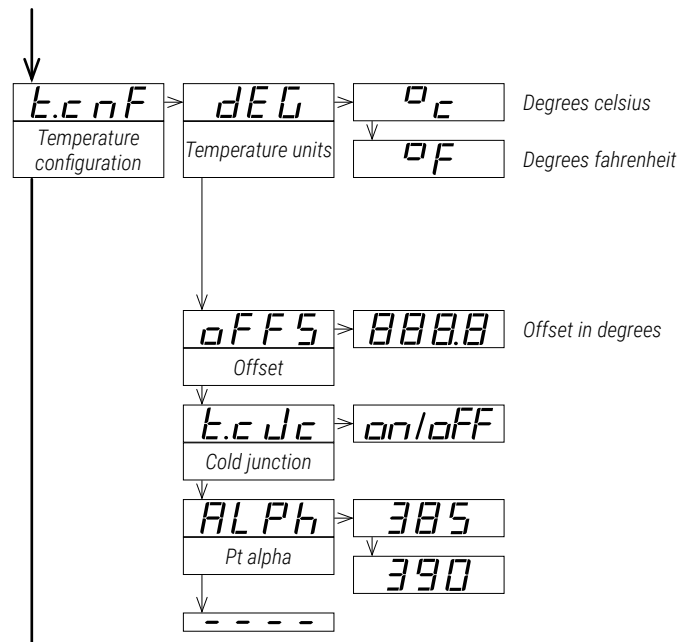

13.5 Process configuration

At the **'Process configuration' (P.cnF)** menu, there is access to the *'field correction'* functions. The *'field correction'* functions allow to modify the *'input signal low'* and *'input signal high'* parameters of the *'Advanced scaling'* menu, based on the actual input signal measured at the input. This parameter applies to process, resistance and potentiometer ranges, and it is disabled for temperature ranges (thermocouples, Pt, NTC ranges).

- select the **'Field correction low' (Fc.Lo)** function to set the actual input signal value at the *'input signal low'* parameter of the *'Advanced scaling'* menu. While measuring the value, the message **'ok'** remains flashing for 5 seconds. When the measure is completed, the instrument returns to the **'Field correction low' (Fc.Lo)** parameter.
- select the **'Field correction high' (Fc.hI)** function to set the actual input signal value at the *'input signal high'* parameter of the *'Advanced scaling'* menu. While measuring the value, the message **'ok'** remains flashing for 5 seconds. When the measure is completed, the instrument returns to the **'Field correction high' (Fc.hI)** parameter.

*Example : a pressure transmitter of 0/10 Bar provides a 4/20 mA signal. The DR-I4P is configured for 4/20 mA input and 4/20 mA output. While setting up the system, you realize that although the real pressure is stable at 0 Bar, the output of the instrument is stable at 4.05 mA. With the *'messages'* function you can check that the input at DR-I4P terminals is also 4.05 mA, and that the signal provided by the pressure transducer is unable to go below this value. Apply the *'field correction low'* function to force the output to be 4.00 mA at the actual input signal detected (4.05 mA).*

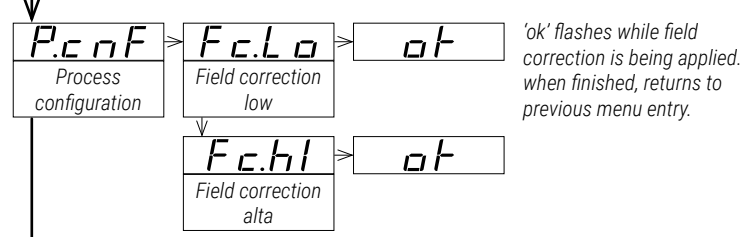

13. Configuration menu (cont.)

13.6 Advanced scaling

At the **'Advanced scaling' (Ad.Sc)** menu, the input and output signal ranges can be customized. When selecting a predefined configuration code, the parameters are configured according to the code selected. The parameters are accessible for manual configuration:

- at the **'Input low signal' (In.Lo)** parameter configure the low input signal value.
 - for temperature sensors, this value is expressed in °C
 - for process signals, this value is expressed in x.xx mA or x.xx Vdc
 - for resistance signals, this value is expressed in KOhms (1.000 KOhms, 10.00 KOhms, 100.0 KOhms or 1000 KOhms)
 - for potentiometer signals, this value is expressed in x.x % of the potentiometer
- at the **'Input high signal' (In.hi)** parameter configure the high input signal value. The units of this parameter value are the same as those expressed in the previous parameter.
- at the **'Output low signal' (ou.Lo)** parameter configure the low output signal value. This value is expressed in x.xx mA or x.xx Vdc.
- at the **'Output high signal' (ou.hi)** parameter configure the high output signal value. This value is expressed in x.xx mA or x.xx Vdc.

Table 31 | EXAMPLE FOR CODE '011' (0/10 VDC=4/20 mA)

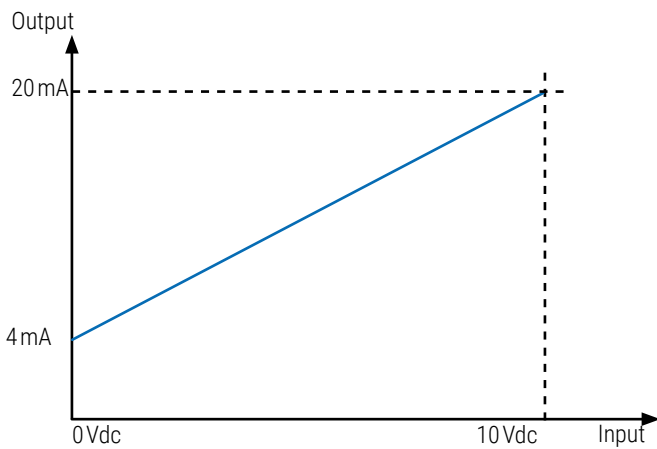

Selecting the predefined code '011' configures a range of 0/10Vdc=4/20mA, and the values configured are as indicated below:

input_low = 0.00 Vdc	output_low = 4.00 mA
input_high = 10.00 Vdc	output_high = 20.00 mA

These four parameters define the relation between the input and the output signal (see Table 31), and can be modified independently, to match the specific input-output relation for your application (see Table 32).

Additionally, a process value can be scaled using the last three parameters of the **'Advanced Scaling' (Ad.Sc)** menu entry. The scaled process value can be accessed through the *'display information'* function (see section 13.7) or the *'messages'* function (see section 13.9). Process parameters are not available for temperature ranges.

- at the **'Process low' (Pr.Lo)** parameter, configure the process value associated to the low input signal value.

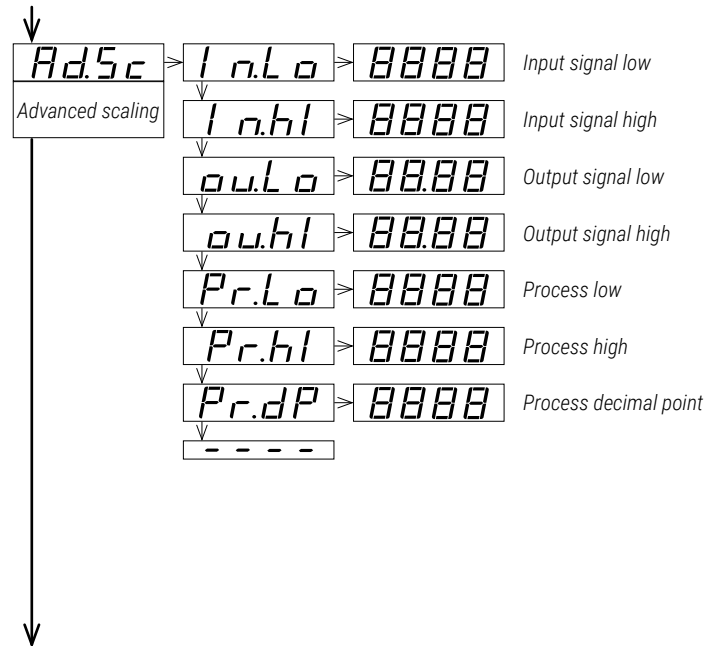
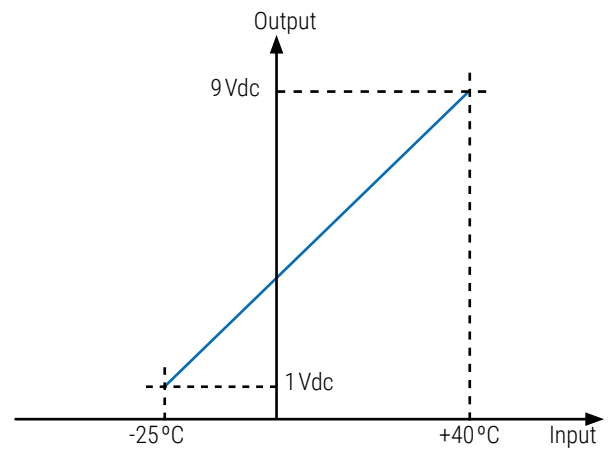

Table 32 | EXAMPLE FOR CUSTOM RANGE (PT100 -25/+40 °C=1/9 VDC)



To configure a Pt100 signal -25/+40°C=1/9Vdc application, select code 177 (-50/+50°C=0/10Vdc) and then configure the parameters below:

input_low = -25 °C	output_low = 1.00 Vdc
input_high = +40 °C	output_high = 9.00 Vdc

- at the **'Process high' (Pr.hi)** parameter, configure the process value associated to the high input signal value.
- at the **'Process decimal point' (Pr.dP)** parameter, configure the decimal point position for the process value.

13. Configuration menu (cont.)

13.7 Display information

At the **'Display information' (dISP)** menu select one parameter to read on display when the instrument is in *'normal mode'* of operation. If you need access to more than one information, see the *'messages'* function (see section 13.9) associated to front key **'LE'** (◀).

- select **'Input signal value' (InP.S)** to read the input signal value and the measurement units (for example : **'Inp tc J °C 528'**).
- select **'Output signal value' (out.S)** to read the output signal value and the measurement units (for example : **'Out mA 12.40'**).
- select **'Label' (LAbL)** to read the value configured at configured at the *'label'* and *'label2'* parameters (see section 13.10).
- select **'Process value' (Proc)** to read the process value as scaled at the process parameters (see section 13.6) (for example: **Proc 150.0'**).
- select **'Percentage' (Prct)** to read the percentage of signal, where '0' is the value assigned to the *'input signal low'* parameter, and '100' is the value assigned to the *'input signal high'* parameter (see section 13.6) (for example : **Prct 23.5'**).

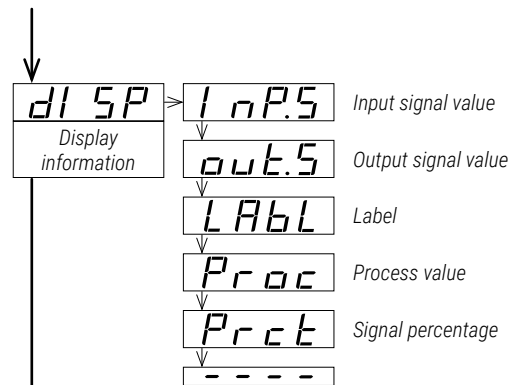

13.8 Key 'UP' ('force' menu)

The key **'UP'** (▲) at the front of the instrument gives access to a configurable list of functions (see section 10.4).

At the **'Key UP ('force' menu) (K.uP)** menu select which functions will be available when pressing the front key **'UP'** (▲). Select **'on'** to activate the desired functions.

- configure **'Force Low' (F.Lo)** to **'on'** to activate the *'Force low'* function menu entry.
- configure **'Force High' (F.hI)** to **'on'** to activate the *'Force high'* function menu entry.
- configure **'Force Set' (F.SET)** to **'on'** to activate the *'Force set'* function menu entry.

The functions configured to **'on'** are available at the *'force'* menu. See section 10.4 for a description on each function and how to operate them.

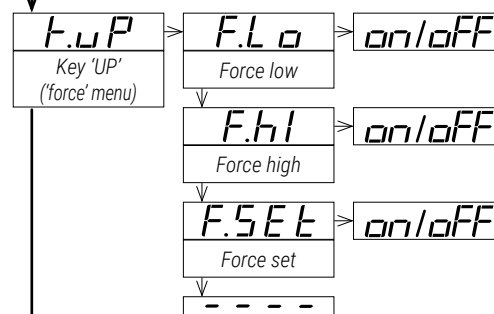

13. Configuration menu (cont.)

13.9 Key 'LE' ('messages' function)

The key 'LE' (◀) at the front of the instrument gives access to a configurable set of information messages.

At the 'Key LE (messages function)' (K.LE) menu, select the informations to be displayed when the front key 'LE' (◀) is pressed (see section 10.5). Select 'on' to activate each information.

- configure 'Input signal value' (InP.S) to 'on' to see the actual input signal value and units (for example: 'Inp tc J °C 528').
- configure 'Output signal value' (out.S) to 'on' to see the actual output signal value and units (for example: 'Out mA 08.3')
- configure 'Label' (LABL) to 'on' to read the value configured at the 'label' and 'label2' parameters (see section 13.10).
- configure 'Process value' (Proc) to 'on' to read the process value as configured at the process parameters (see section 13.6) (for example: 'Proc 1500').
- configure 'Percentage' (Prct) to 'on' to see the actual percentage of signal, where '0' is the value assigned to the 'input signal low' parameter, and '100' is the value assigned to the 'input signal high' parameter (see section 13.6) (for example: 'Prct 23.5').

When more than one parameter is set to 'on', values will be displayed sequentially, in the same order as they are listed in the menu, with a middle dash '-' between them. When all information has been displayed, the instrument returns to 'normal mode' of operation.

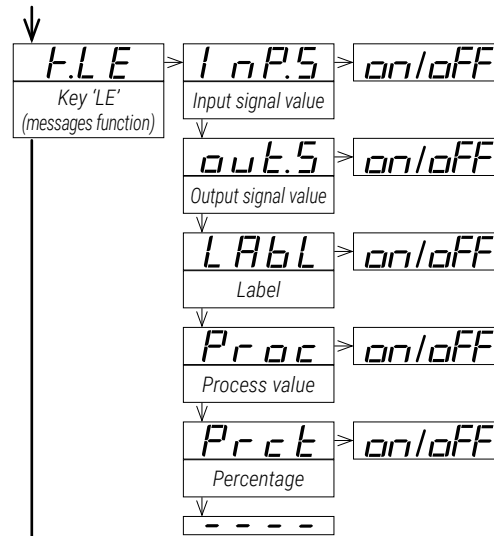

13.10 'Tools' menu

The 'Tools' (tool) menu groups several functions.

- at the 'Eco mode' (Eco) parameter, define the time to wait before the display is powered off (while in 'normal mode' of operation). Default value is 60 seconds. Configure '0' to disable the function and maintain the display always on.
- at the 'SOS mode' (SoS) parameter select 'on' to activate the output signal to a predefined value. Select the value from 0 to 100% of the active output range (4/20mA or 0/10Vdc). To deactivate the 'SOS mode' select 'off'. See section 6 for more information on the 'SOS mode'.
- at the 'Label' (LABL) parameter, define an alphanumerical value to be displayed on the display, when the instrument is in 'normal mode' of operation, or at the 'messages' function when the key 'LE' (◀) is pressed. The label can be used to identify the instrument with its own internal factory code. If more than four characters are needed, configure the 'Label2' (LbL.2) parameter. The total label value is the characters at 'label' followed by the characters at 'label2'. For additional information and a list of available characters, see section 7.
- at the 'On error' (on.Er) parameter, configure the behavior of the output signal, in case of error at the input signal (see section 16).
 - select 'Output to high' (to.hI) to force the output signal to overrange to maximum value
 - select 'Output to low' (to.Lo) to force the output signal to underrange to minimum value
 - select 'Standard output' (StdR) to overrange output signal to maximum value in case of input signal overrange, and to underrange output signal to minimum value in case of input signal underrange.

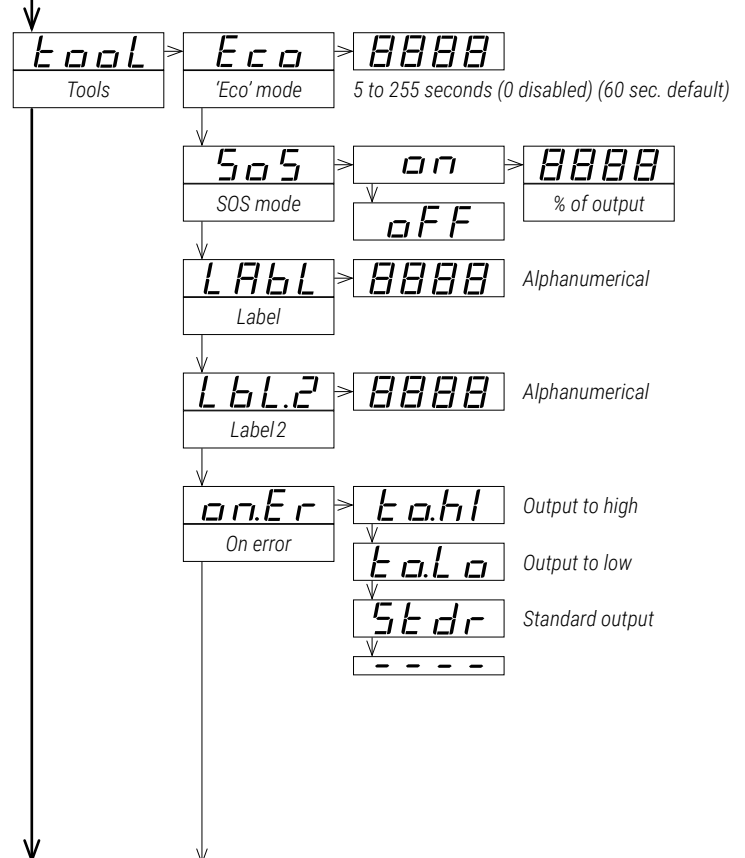

13. Configuration menu (cont.)

- at the '**On 'SQ'**' (**on.Sq**) parameter, configure the behavior of the output signal when the operator is inside '*configuration menu*' (see section 10.3).

- select '**Output to high**' (**to.hI**) to force the output signal to overrange to maximum value
- select '**Output to low**' (**to.Lo**) to force the output signal to underrange to minimum value
- select '**Hold output**' (**hoLd**) to hold the output signal while the operator remains inside '*configuration menu*'.

- at the '**Power filter**' (**P.FLt**) parameter, select a filter for specific power frequency rejection. The filter selection has an effect on the response times (see section 12).

- select '**No filter**' (**nonE**) to disable frequency rejection filters. This enables the fastest response time.
- select '**50 Hz filter**' (**50.hZ**) to enable rejection to 50 Hz frequency.
- select '**60 Hz filter**' (**60.hZ**) to enable rejection to 60 Hz frequency.
- select '**50 and 60 Hz filter**' (**both**) to enable rejection to both 50 Hz and 60 Hz frequencies. This is the slowest response time.

- at the '**Average filter**' (**AVr**) parameter, configure the recursive filter to be applied to measured input signal. The filter can be used to reduce oscillations on noisy signals. Configure the filter strength between '0' and '100'. The filter is stronger with higher values. Increasing the strength of the filter slows the response speed of the instrument. Value '0' disables the filter.

- at the '**Dead band**' (**d.bnd**) parameter set a value between '0.0%' and '100.0%'. This is a percentage of the '*input signal high*' parameter configured at the '*Advanced scaling*' section. Input signals below this value, are treated as a '0'. This parameter applies to process, resistance and potentiometer ranges, and it is disabled for temperature ranges (thermocouples, Pt, Ntc).

example : instrument configured with code '011' (0/10 Vdc = 4/20 mA) and 'input signal high' parameter modified to 8 Vdc for an effective input - output relation of 0/8 Vdc = 4/20 mA'. Configure the 'Dead band' parameter to '1.0' to set a dead band value of 0.08 Vdc. All signals below 0.08 Vdc will be treated as 0 Vdc, and the output will be 4 mA.

- the '**Version**' (**VEr**) parameter informs about the firmware version running in the instrument.

- at the '**Password**' (**PASS**) parameter define a 4 digit code to block access to the '*configuration menu*'. Activate the password to prevent access to the instrument configuration by non authorized personnel. To activate the '*Password*' function select '**on**', enter the code and validate. The password will be requested when accessing the '*configuration menu*'. The password does not block access to the '*force*' menu. To deactivate the password, set the password parameter to '**oFF**'.

- at the '**Factory reset**' (**FAct**) parameter select '**yes**' to activate the default factory configuration (see section 15 for a list of factory default parameters).

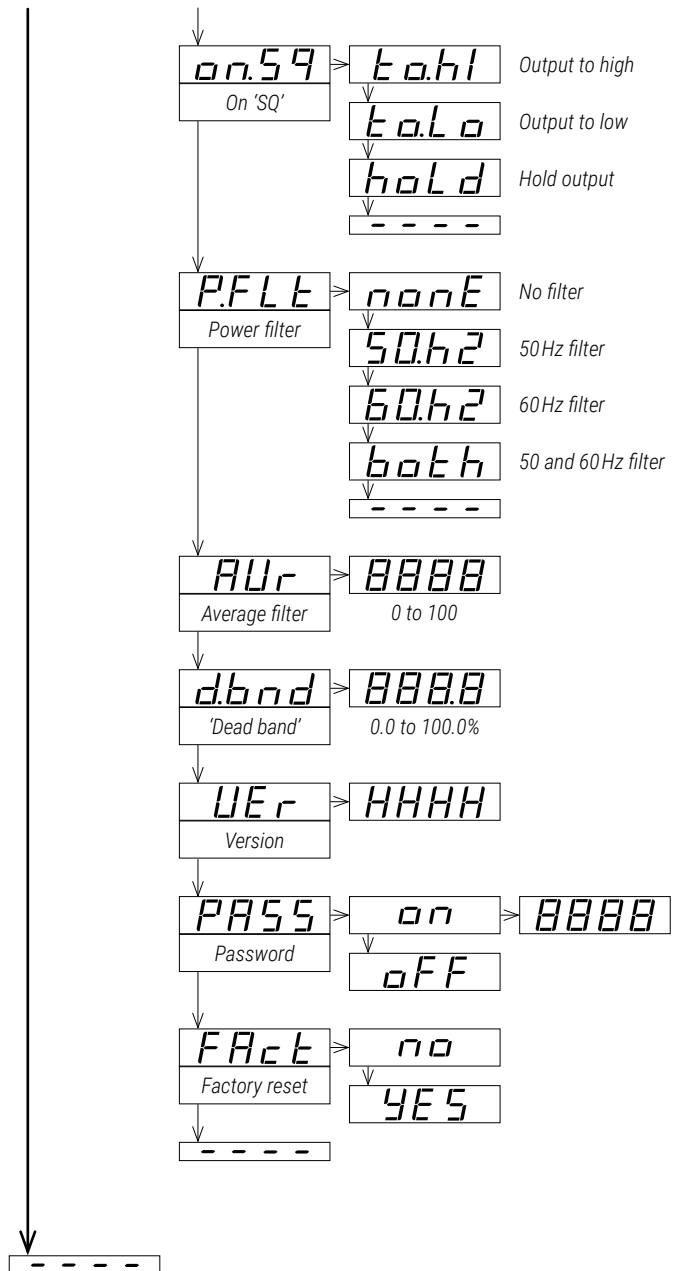

This page blank

14. Full configuration menu

Press 'SQ' (■) for 1 second to access the 'configuration menu'. For a description on how to operate inside the menus see section 10. For a full vision of the 'configuration menu' structure see section 13.

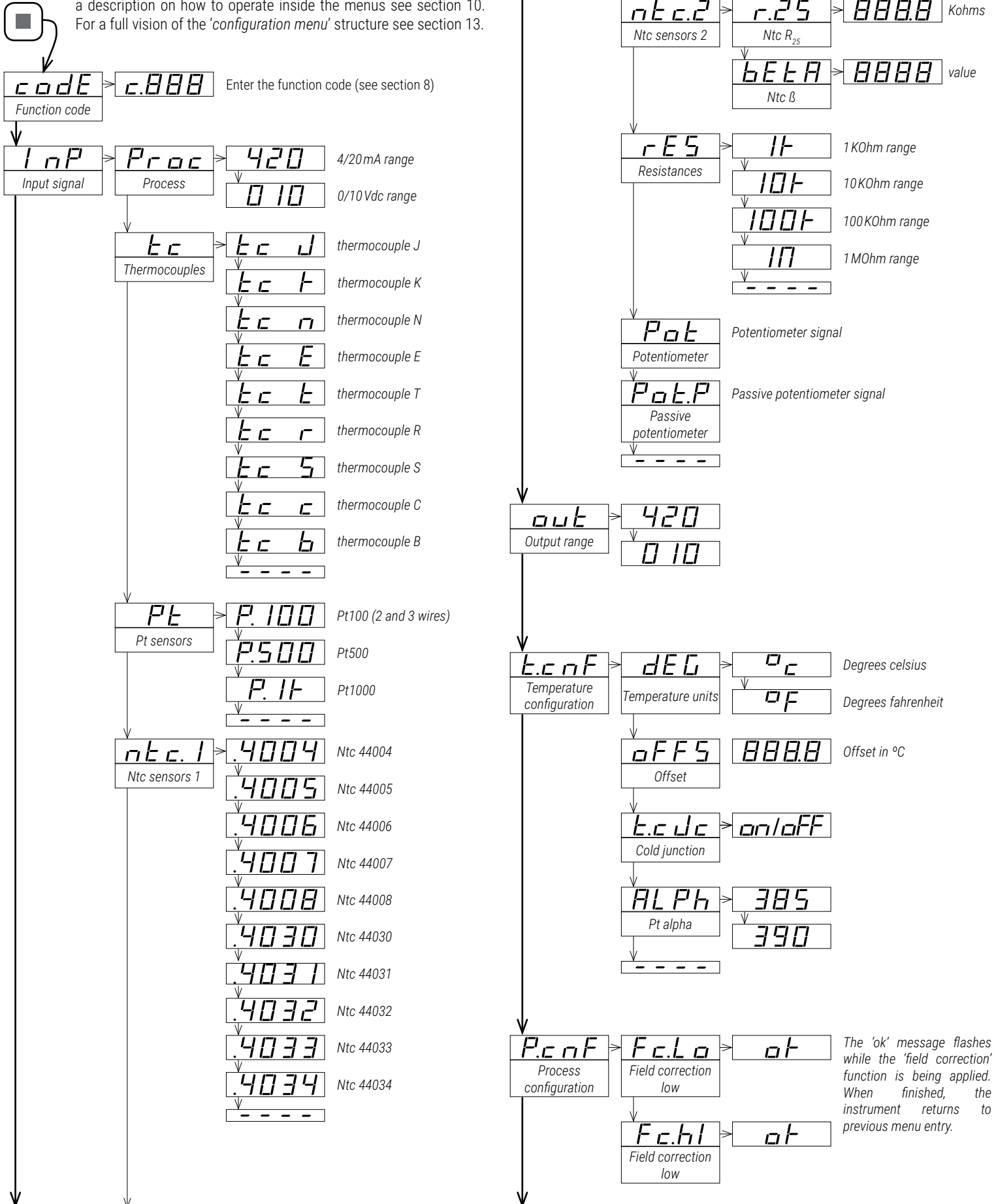

The 'ok' message flashes while the 'field correction' function is being applied. When finished, the instrument returns to previous menu entry.

14. Full configuration menu (cont.)

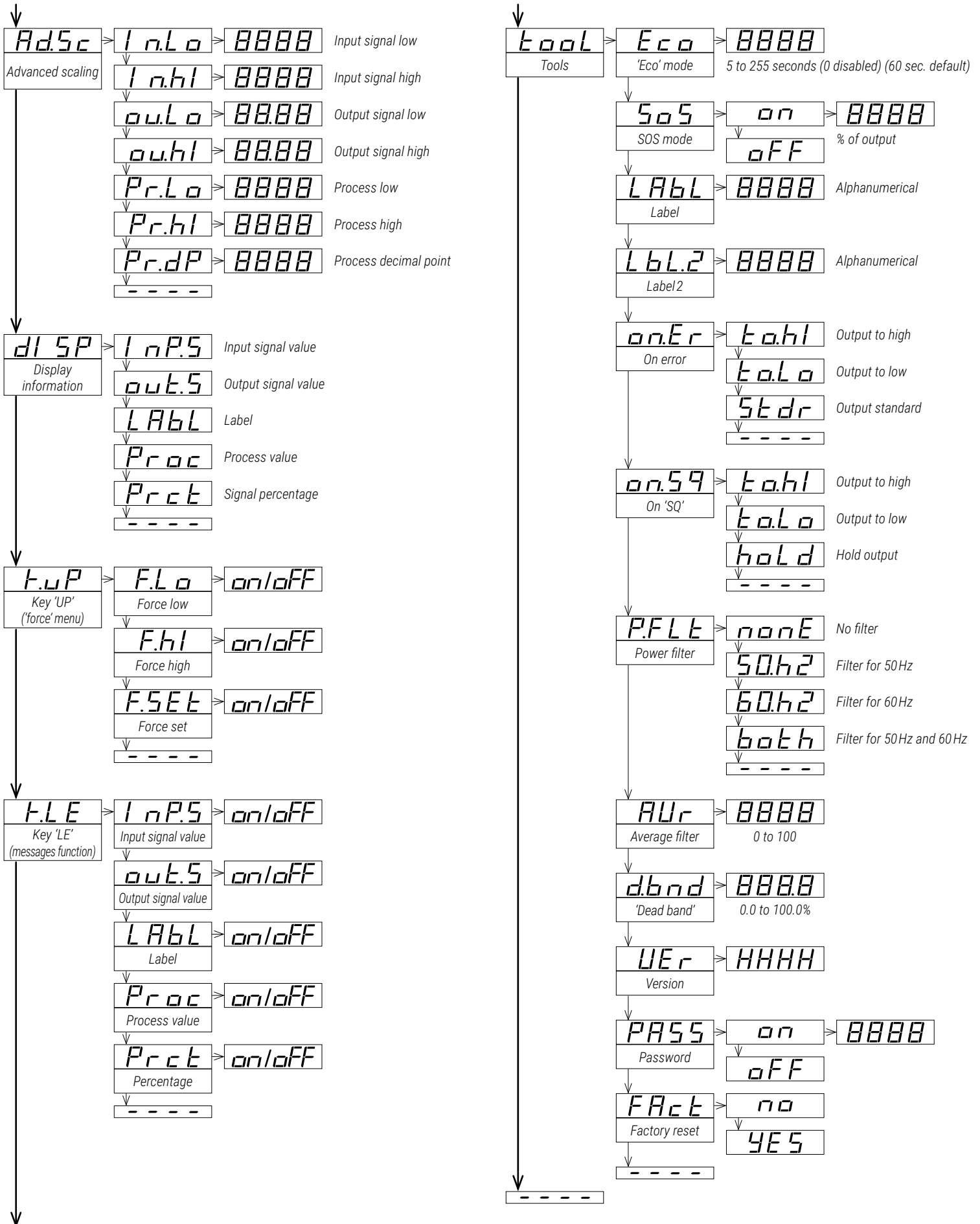

15. Factory default parameters

Function code (codE)	10	[c.010]
Input range (InP)	4/20 mA	
Output range (out)	4/20 mA	
Temperature configuration (t.cnF)		
Temperature units (dEG)	°C	
Offset (oFFS)	0.0	
Cold junction (t.cJc)	on	
Pt alpha (ALPh)	385	
Advanced scaling (Ad.Sc)		
Input signal low (In.Lo)	4.00	[mA]
Input signal high (In.hl)	20.00	[mA]
Output signal low (ou.Lo)	4.00	[mA]
Output signal high (ou.hl)	20.00	[mA]
Process low (Pr.Lo)	0	
Process high (Pr.hl)	1000	
Process decimal point (Pr.dP)	8888	(no decimal point)
Display information (dISP)	Input signal value (InP.S)	
Key ' UP ' ('force' menu) (K.uP)		
Force low (F.Lo)	on	
Force high (F.hl)	on	
Force set (FSET)	on	
Key ' LE ' ('messages' function) (K.LE)		
Input signal value (InP.S)	off	
Output signal value (out.S)	on	
Label (LABL)	off	
Process value (Proc)	off	
Percentage (Prct)	off	
Tools (tool)		
'Eco' mode (Eco)	60	[seconds]
SOS mode (SoS)	off	
Label (LABL)	LABL	
Label 2 (LbL.2)	----	(disabled)
On error (on.Er)	to.hl	(output to maximum value)
On 'SQ' (on.Sq)	to.hl	(output to maximum value)
Power filter (P.Flt)	both	(50 and 60Hz filter)
Average filter (AVr)	0	(disabled)
Dead band (d.bnd)	0.0	(disabled)
Password (PASS)	off	(disabled)

RESET TO DEFAULT FACTORY PARAMETERS

To recover the instrument to default factory parameters, enter into 'configuration menu' and go to 'Tools' / 'Factory reset' and select 'yes'

- access the 'configuration menu' (press key '**SQ**' (■) for 1 second)
- press key '**UP**' (▲) to locate 'tools' and press '**SQ**' (■)
- parameter 'Eco mode' appears on display
- press key '**UP**' (▲) to locate 'Factory reset' and press '**SQ**' (■)
- value 'no' appears on display
- press key '**UP**' (▲) and 'Yes' appears on display
- press key '**SQ**' (■) to apply the factory reset
 - the leds light a round shape while the new configuration is applied
 - the start up message appears ('mA 420')
 - the actual signal input value is displayed
- the instrument is in 'normal mode' of operation

16. Error codes and messages

In case of error, the error code is shown flashing on the digits. The error code remains active on display until the problem that caused the error is solved. In case of multiple error codes, solve the first problem to see the next active error code. The error code is not visible inside 'configuration mode' or inside the 'force' menu.

While on error, the output can be configured to overrange (to 21 mA, 10.4Vdc), to underrange (to 3 mA or -0.05Vdc) or to hold value. See the 'On error' (**on.Er**) parameter at section 13.10.

Table 33 | Error codes

Error	Description
Er.01'	Password error. The password code entered is not correct.
Er.02'	Input hardware overrange. The input signal is higher than the maximum signal that can be measured. The output is fixed to 21 mA or 10.4Vdc.
Er.03'	Input hardware underrange. The input signal is lower than the minimum signal that can be measured. The output is fixed to 3 mA or -0.05Vdc.
Er.04'	Output hardware overrange. The output signal should be higher than the maximum output signal that can be generated.
Er.05'	Output hardware underrange. The output signal should be lower than the minimum output signal that can be generated.
Er.08'	Scaled input slope not valid. The values for 'Input signal low' (In.Lo) and 'Input signal high' (In.hl) can not be the same. Enter a different value to validate the parameter (see section 13.6).
Er.09'	Scaled output slope not valid. The values for 'Output signal low' (ou.Lo) and 'Output signal high' (ou.hl) can not be the same. Enter a different value to validate the parameter (see section 13.6).
Er.10'	Scaled process display slope not valid. The values for 'Process low' (Pr.Lo) and 'Process high' (Pr.hl) can not be the same. Enter a different value to validate the parameter (see section 13.6).
Er.11'	Short circuit error. The input signal detects a short circuit.
Er.12'	Sensor break. Pt100 3 rd wire connected to Pt+.
Er.13'	Overload at the 4/20mA input. The input signal detected is higher than 48 mA, and the instrument has opened the circuit. The instrument tries to reconnect every 1 second.
Er.14'	The third wire of the Pt100 is open (not connected, broken, or third wire resistance is higher than 15 Ohms). Shortcircuit terminals 1 and 2 to overlook the third wire.

Messages do not affect the output signal, and do not trigger the 'On error' (**on.Er**) function.

Table 34 | Messages

Error	Description
'd.oVr'	Display overrange. The display value should be higher than the maximum value that can be displayed.
'd.udr'	Display underrange. The display value should be lower than the minimum value that can be displayed.
'-nA-'	Function not available. For the actual configuration, the function is not available.

17. Precautions on installation



Check the documentation when you find this symbol, to know the nature of a potential danger and actions to prevent it.



Risk of electrical shock. Instrument terminals can be connected to dangerous voltage.



Instrument protected with double isolation. No earth connection required.



Instrument conforms to CE rules and regulations.

This instrument has been designed and verified conforming to the 61010-1 CE Security Regulation, for industrial applications. Installation of this instrument must be performed by qualified personnel only. This manual contains the appropriate information for the installation. Using the instrument in ways not specified by the manufacturer may lead to a reduction of the specified protection level. Disconnect the instrument from all external circuits before starting any maintenance and / or installation action.

The instrument does not have a general switch and will start operation as soon as power is connected. The instrument does not have protection fuse, the fuse must be added during installation.

The instrument is designed to be DIN rail mounted, inside a closed cabinet, protected from direct impacts. An appropriate ventilation of the instrument must be assured. Do not expose the instrument to excess of humidity. Maintain clean by using a humid rag and do NOT use abrasive products such as alcohols, solvents, etc. General recommendations for electrical installations apply, and for proper functionality we recommend : if possible, install the instrument far from electrical noise or magnetic field generators such as power relays, electrical motors, speed variators, ... If possible, do not install along the same conduits power cables (power, motor controllers, electrovalves, ...) together with signal and/or control cables. The use of shielded cables is recommended to prevent the coupling of environmental electromagnetic noise, connected to earth only one cable end side. Before proceeding to the power connection, verify that the voltage level available matches the power levels indicated in the label on the instrument. In case of fire, disconnect the instrument from the power line, fire alarm according to local rules, disconnect the air conditioning, attack fire with carbonic snow, never with water.



Conformity with security regulations EN-61010-1 requires a closed front cover. There is no need to open the front cover under normal usage or configuration. The output terminal prevents the front cover from opening. An open front cover may expose areas with dangerous voltages. Remove connections with dangerous voltages before opening. Only to be performed by qualified operators.

18. Warranty

This instrument is warranted against all manufacturing defects for a period of 36 months, as requested by the European legislation. This warranty does not apply in case of misuse or accident, and the scope of the warranty is limited to repair of the instrument, not being the manufacturer responsible for additional damages or additional costs. Within the warranty period and after examination by the manufacturer, the unit will be repaired or substituted when found to be defective.

19. CE declaration of conformity

Products **DR-I4P**

The manufacturer declares that the instruments indicated comply with the directives and rules indicated below.

Electromagnetic compatibility directive 2014/30/EU

Low voltage directive 2014/35/EU

ROHS directive 2015/863/EU

WEEE directive 2012/19/EU

Security rules EN-61010-1

Instrument Fixed, Permanently connected

Pollution degree 1 and 2 (without condensation)

Isolation Double

Overvoltage category 2

Electromagnetic compatibility rules EN-61326-1

EM environment Industrial

CISPR 11 Instrument Class A & Class B Group 1

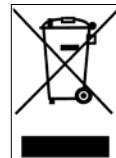

According to directive 2012/19/EU, electronic equipment must be recycled in a selective and controlled way at the end of its useful life.

WARRANTY/DISCLAIMER

OMEGA ENGINEERING, INC. warrants this unit to be free of defects in materials and workmanship for a period of **13 months** from date of purchase. OMEGA's WARRANTY adds an additional one (1) month grace period to the normal **one (1) year product warranty** to cover handling and shipping time. This ensures that OMEGA's customers receive maximum coverage on each product.

If the unit malfunctions, it must be returned to the factory for evaluation. OMEGA's Customer Service Department will issue an Authorized Return (AR) number immediately upon phone or written request. Upon examination by OMEGA, if the unit is found to be defective, it will be repaired or replaced at no charge. OMEGA's WARRANTY does not apply to defects resulting from any action of the purchaser, including but not limited to mishandling, improper interfacing, operation outside of design limits, improper repair, or unauthorized modification. This WARRANTY is VOID if the unit shows evidence of having been tampered with or shows evidence of having been damaged as a result of excessive corrosion; or current, heat, moisture or vibration; improper specification; misapplication; misuse or other operating conditions outside of OMEGA's control. Components in which wear is not warranted, include but are not limited to contact points, fuses, and triacs.

OMEGA is pleased to offer suggestions on the use of its various products. However, OMEGA neither assumes responsibility for any omissions or errors nor assumes liability for any damages that result from the use of its products in accordance with information provided by OMEGA, either verbal or written. OMEGA warrants only that the parts manufactured by it will be as specified and free of defects. OMEGA MAKES NO OTHER WARRANTIES OR REPRESENTATIONS OF ANY KIND WHATSOEVER, EXPRESS OR IMPLIED, EXCEPT THAT OF TITLE, AND ALL IMPLIED WARRANTIES INCLUDING ANY WARRANTY OF MERCHANTABILITY AND FITNESS FOR A PARTICULAR PURPOSE ARE HEREBY DISCLAIMED. LIMITATION OF LIABILITY: The remedies of purchaser set forth herein are exclusive, and the total liability of OMEGA with respect to this order, whether based on contract, warranty, negligence, indemnification, strict liability or otherwise, shall not exceed the purchase price of the component upon which liability is based. In no event shall OMEGA be liable for consequential, incidental or special damages.

CONDITIONS: Equipment sold by OMEGA is not intended to be used, nor shall it be used: (1) as a "Basic Component" under 10 CFR 21 (NRC), used in or with any nuclear installation or activity; or (2) in medical applications or used on humans. Should any Product(s) be used in or with any nuclear installation or activity, medical application, used on humans, or misused in any way, OMEGA assumes no responsibility as set forth in our basic WARRANTY/DISCLAIMER language, and, additionally, purchaser will indemnify OMEGA and hold OMEGA harmless from any liability or damage whatsoever arising out of the use of the Product(s) in such a manner.

RETURN REQUESTS/INQUIRIES

Direct all warranty and repair requests/inquiries to the OMEGA Customer Service Department. BEFORE RETURNING ANY PRODUCT(S) TO OMEGA, PURCHASER MUST OBTAIN AN AUTHORIZED RETURN (AR) NUMBER FROM OMEGA'S CUSTOMER SERVICE DEPARTMENT (IN ORDER TO AVOID PROCESSING DELAYS). The assigned AR number should then be marked on the outside of the return package and on any correspondence.

The purchaser is responsible for shipping charges, freight, insurance and proper packaging to prevent breakage in transit.

FOR **WARRANTY** RETURNS, please have the following information available BEFORE contacting OMEGA:

1. Purchase Order number under which the product was PURCHASED,
2. Model and serial number of the product under warranty, and
3. Repair instructions and/or specific problems relative to the product.

FOR **NON-WARRANTY** REPAIRS, consult OMEGA for current repair charges. Have the following information available BEFORE contacting OMEGA:

1. Purchase Order number to cover the COST of the repair,
2. Model and serial number of the product, and
3. Repair instructions and/or specific problems relative to the product.

OMEGA's policy is to make running changes, not model changes, whenever an improvement is possible. This affords our customers the latest in technology and engineering.

OMEGA is a trademark of OMEGA ENGINEERING, INC.

© Copyright 2019 OMEGA ENGINEERING, INC. All rights reserved. This document may not be copied, photocopied, reproduced, translated, or reduced to any electronic medium or machine-readable form, in whole or in part, without the prior written consent of OMEGA ENGINEERING, INC.

Where Do I Find Everything I Need for Process Measurement and Control? **OMEGA...Of Course!** *Shop online at omega.com*

TEMPERATURE

- Thermocouple, RTD & Thermistor Probes, Connectors, Panels & Assemblies
- Wire: Thermocouple, RTD & Thermistor
- Calibrators & Ice Point References
- Recorders, Controllers & Process Monitors
- Infrared Pyrometers

PRESSURE, STRAIN AND FORCE

- Transducers & Strain Gages
- Load Cells & Pressure Gages
- Displacement Transducers
- Instrumentation & Accessories

FLOW/LEVEL

- Rotameters, Gas Mass Flowmeters & Flow Computers
- Air Velocity Indicators
- Turbine/Paddlewheel Systems
- Totalizers & Batch Controllers

pH/CONDUCTIVITY

- pH Electrodes, Testers & Accessories
- Benchtop/Laboratory Meters
- Controllers, Calibrators, Simulators & Pumps
- Industrial pH & Conductivity Equipment

DATA ACQUISITION

- Communications-Based Acquisition Systems
- Data Logging Systems
- Wireless Sensors, Transmitters, & Receivers
- Signal Conditioners
- Data Acquisition Software

HEATERS

- Heating Cable
- Cartridge & Strip Heaters
- Immersion & Band Heaters
- Flexible Heaters
- Laboratory Heaters

ENVIRONMENTAL MONITORING AND CONTROL

- Metering & Control Instrumentation
- Refractometers
- Pumps & Tubing
- Air, Soil & Water Monitors
- Industrial Water & Wastewater Treatment
- pH, Conductivity & Dissolved Oxygen Instruments