

1 YEAR
WARRANTY



User's Guide



Shop online at

omega.com[®]

OMEGA[®]

omega.com

e-mail: info@omega.com

*For latest product manuals:
omegamannual.info*

ISO 9001
CERTIFIED
CORPORATE QUALITY

STAMFORD, CT

ISO 9001
CERTIFIED
CORPORATE QUALITY

MANCHESTER, UK

FMA 5400A/FMA 5500A Mass Flow Controllers



OMEGAnet® Online Service omega.com	Internet e-mail info@omega.com
---	---

Servicing North America:

U.S.A.: Omega Engineering, Inc., One Omega Drive, P.O. Box 4047
ISO 9001 Certified Stamford, CT 06907-0047
Toll-Free: 1-800-826-6342 Tel: (203) 359-1660
FAX: (203) 359-7700 e-mail: info@omega.com

Canada: 976 Bergar
Laval (Quebec), Canada H7L 5A1
Toll-Free: 1-800-826-6342 TEL: (514) 856-6928
FAX: (514) 856-6886 e-mail: info@omega.ca

For immediate technical or application assistance:

U.S.A. and Canada: Sales Service: 1-800-826-6342/1-800-TC-OMEGA®
Customer Service: 1-800-622-2378/1-800-622-BEST®
Engineering Service: 1-800-872-9436/1-800-USA-WHEN®

Mexico: En Español: 001 (203) 359-7803 FAX: (001) 203-359-7807
info@omega.com.mx e-mail: espanol@omega.com

Servicing Europe:

Benelux: Managed by the United Kingdom Office
Toll-Free: 0800 099 3344 TEL: +31 20 347 21 21
FAX: +31 20 643 46 43 e-mail: sales@omega.nl

Czech Republic: Frystatska 184
733 01 Karviná, Czech Republic
Toll-Free: 0800-1-66342 TEL: +420-59-6311899
FAX: +420-59-6311114 e-mail: info@omegashop.cz

France: Managed by the United Kingdom Office
Toll-Free: 0800 466 342 TEL: +33 (0) 161 37 29 00
FAX: +33 (0) 130 57 54 27 e-mail: sales@omega.fr

Germany/Austria: Daimlerstrasse 26
D-75392 Deckenpfronn, Germany
Toll-Free: 0 800 6397678 TEL: +49 (0) 7059 9398-0
FAX: +49 (0) 7056 9398-29 e-mail: info@omega.de

United Kingdom: OMEGA Engineering Ltd.
ISO 9001 Certified One Omega Drive, River Bend Technology Centre, Northbank
Irlam, Manchester M44 5BD England
Toll-Free: 0800-488-488 TEL: +44 (0)161 777-6611
FAX: +44 (0)161 777-6622 e-mail: sales@omega.co.uk

It is the policy of OMEGA Engineering, Inc. to comply with all worldwide safety and EMC/EMI regulations that apply. OMEGA is constantly pursuing certification of its products to the European New Approach Directives. OMEGA will add the CE mark to every appropriate device upon certification.

The information contained in this document is believed to be correct, but OMEGA accepts no liability for any errors it contains, and reserves the right to alter specifications without notice.

WARNING: These products are not designed for use in, and should not be used for, human applications.

TABLE OF CONTENTS

1. UNPACKING THE FMA 5400A/5500A MASS FLOW CONTROLLER.....	1
1.1 Inspect Package for External Damage.....	1
1.2 Unpack the Mass Flow Controller.....	1
1.3 Returning Merchandise for Repair.....	1
2. INSTALLATION.....	2
2.1 Primary Gas Connections.....	2
2.2 Electrical Connections.....	2
2.2.1 Valve Control Configuration.....	5
2.2.2 Remote LCD Readouts.....	6
2.2.3 Panel Mounting Readouts.....	6
3. PRINCIPLE OF OPERATION.....	7
4. SPECIFICATIONS.....	7
4.1 CE Compliance.....	10
4.2 Flow Capacities.....	10
5. OPERATING INSTRUCTIONS.....	11
5.1 Preparation and Warm Up.....	11
5.2 Flow Signal Output Readings.....	12
5.3 Swamping Condition.....	12
5.4 Setpoint Reference Signal.....	13
5.5 Valve OFF Control (Open Collector NPN Compatible).....	14
5.6 Valve Test/Purge.....	14
6. MAINTENANCE.....	15
6.1 Introduction.....	15
6.2 Flow Path Cleaning.....	15
6.2.1 Cleaning the Inlet Filter Screen in FMA Models.....	15
6.2.2 Valve Maintenance for FMA 5400A/5500A Series Max. Flow 10, 50 and 100 L/min.....	16 18
7. CALIBRATION PROCEDURES.....	18
7.1 Flow Calibration.....	19
7.2 Calibration of FMA 5400A/5500A Series Max. Flow 10, 50 and 100 L/min.....	19
7.2.1 Connections and Initial Warm Up.....	20
7.2.2 Zero Adjustment.....	20
7.2.3 SPAN Adjustment.....	20
7.2.4 Linearity Adjustment.....	20

7.2.4.1	Disable Solenoid Valve in FMA 5400A/5500A Series Max. Flow 10, 50 and 100 L/min.....	20
7.2.5	Connections and Initial Warm Up.....	21
7.2.6	ZERO Adjustment.....	21
7.2.7	25% Flow Adjustment Using R33 Potentiometer.....	21
7.2.8	10% Flow Adjustment.....	22
7.2.9	25% Flow Adjustment (using R52 potentiometer).....	22
7.2.10	50% Flow Adjustment.....	22
7.2.11	75% Flow Adjustment.....	22
7.2.12	100% Flow Adjustment.....	22
7.2.13.	Valve adjustment.....	23
7.2.13.1	Valve Adjustment for Series Max. Flow 10, 50, 100 L/min.....	23
7.2.14	Close Loop Full Scale Flow Adjustment.....	23
7.2.15	10% Close Loop Flow Adjustment (using R33 potentiometer).....	23
7.2.16	25% Close Loop Flow Adjustment (using R52 potentiometer).....	23
7.2.17	Close Loop 25% Flow Adjustment (using R33 potentiometer).....	23
7.2.18	Close Loop 50% Flow Adjustment.....	24
7.2.19	Close Loop 75% Flow Adjustment.....	24
7.2.20	Close Loop 100% Flow Adjustment.....	24
7.3	Calibration of FMA 5400A/5500A Series Max. Flow 200, 500 and 1000 L/min.....	24
7.3.1	Connections and Initial Warm Up.....	25
7.3.2	ZERO Adjustment.....	25
7.3.3	SPAN Adjustment.....	25
7.3.4	Linearity Adjustment.....	26
7.3.4.1	Open Motorized Valve in FMA 5400A/5500A Series Max. Flow 200, 500 and 1000 L/min.....	26
7.3.5	Connections and Initial Warm Up.....	26
7.3.6	ZERO Adjustment.....	26
7.3.7	25% Flow Adjustment.....	26
7.3.8	50% Flow Adjustment.....	27
7.3.9	75% Flow Adjustment.....	27
7.3.10	100% Flow Adjustment.....	27
7.3.11.	Valve adjustment.....	27
7.3.11.1	Valve Adjustment for FMA 5400A/5500A Series Max. Flow 200, 500 and 1000 L/min.....	27
7.3.12	Full Scale Flow Adjustment.....	28
7.3.13	25% Flow Adjustment.....	28
7.3.14	50% Flow Adjustment.....	28

7.3.15	75% Flow Adjust	7.3.16 100% Flow Adjustment.....	28
7.4	LCD Display Scaling.....		28
7.4.1	Access LCD Display Circuit.....		28
7.4.2	Adjust Scaling.....		29
7.4.3	Change Decimal Point.....		29
8.	TROUBLESHOOTING.....		29
8.1	Common Conditions.....		29
8.2	General Troubleshooting Guide.....		30
8.3	FMA 5400A/5500A Series Max. Flow 10, 50 and 100 L/min Valve Related Troubleshooting.....		32
8.4	Technical Assistance.....		35
9.	CALIBRATION CONVERSIONS FROM REFERENCE GASES.....		35
APPENDIX 1	COMPONENT DIAGRAM.....		36
APPENDIX 2	GAS FACTOR TABLE (“K” FACTORS).....		38
APPENDIX 3	DIMENSIONAL DRAWINGS.....		42
APPENDIX 4	WARRANTY.....		46

1. UNPACKING THE FMA 5400A/5500A MASS FLOW CONTROLLER

1.1 Inspect Package for External Damage



CAUTION: Some of the IC devices used in the FMA 5400A/5500A are Electro Static Discharge (ESD) sensitive and may be damaged by improper handling. When wiring the interface connector, adjusting or servicing the meter, use of a grounded ESD protection wrist strap is required to prevent inadvertent damage to the CMOS integral solid state circuitry. When 15 pins inter face D-connector is not used do not remove factory installed ESD protection cover.

Your FMA 5400A/5500A Mass Flow Controller was carefully packed in a sturdy cardboard carton, with anti-static cushioning materials to withstand shipping shock. Upon receipt, inspect the package for possible external damage. In case of external damage to the package contact the shipping company immediately.

1.2 Unpack the Mass Flow Controller

Open the carton carefully from the top and inspect for any sign of concealed shipping damage. In addition to contacting the shipping carrier please forward a copy of any damage report to OMEGA® directly.

When unpacking the instrument please make sure that you have all the items indicated on the Packing List. Please report any shortages promptly.

1.3 Returning Merchandise for Repair

Please contact an OMEGA® customer service representative and request a **Return Authorization Number (AR)**.

It is mandatory that any equipment returned for servicing be purged and neutralized of any dangerous contents including but not limited to toxic, bacterially infectious, corrosive or radioactive substances. No work shall be performed on a returned product unless the customer submits a fully executed, signed SAFETY CERTIFICATE. Please request form from the Service Manager.

2. INSTALLATION

2.1 Primary Gas Connections

Please note that the FMA 5400A/5500A Mass Flow Controller will not operate with liquids. Only clean gases are allowed to be introduced into the instrument. Contaminated gases must be filtered to prevent the introduction of impediments into the sensor.



CAUTION: It is the users responsibility to determine if the instrument is appropriate for their OXYGEN application, and for specifying O2 cleaning service if required. OMEGA is not liable for any damage or personal injury, whatsoever, resulting from the use of this instrument for oxygen gas.

Attitude sensitivity of the Mass Flow Controller is $\pm 15^\circ$. This means that the gas flow path of the flow meter must be horizontal within those stated limits. Should there be need for a different orientation of the meter, re-calibration may be necessary. It is also preferable to install the FMA 5400A/5500A transducer in a stable environment, free of frequent and sudden temperature changes, high moisture, and drafts.

Prior to connecting gas lines inspect all parts of the piping system including ferules and fittings for dust or other contaminants. Be sure to observe the direction of gas flow as indicated by the arrow on the front of the meter when connecting the gas system to be monitored.

Insert tubing into the compression fittings until the ends of the properly sized tubings home flush against the shoulders of the fittings. Compression fittings are to be tightened according to the manufacturer's instructions to one and one quarter turns. Avoid over tightening which will seriously damage the Restrictor Flow Elements (RFE's)!

Compression fittings should not be removed unless the meter is being cleaned or calibrated for a new flow range.

Using a Helium Leak Detector or other equivalent method perform a thorough leak test of the entire system. (All FMA 5400A/5500A's are checked prior to shipment for leakage within stated limits. See specifications in this manual.)

2.2 Electrical Connection



CAUTION: Some of the IC devices used in the FMA 5400A/5500A are Electro Static Discharge (ESD) sensitive and may be damaged by improper handling. When wiring the interface connector, adjusting or servicing the meter, use of a grounded ESD protection wrist strap is required to prevent inadvertent damage to the CMOS integral solid state circuitry. When 15 pins interface D-connector is not used do not remove factory installed ESD protection cover.



CAUTION: WIRING THE FMA 5400A/5500A METER OR CHANGING NJ1 JUMPERS CONFIGURATION WITH THE POWER ON MAY RESULT IN INTERNAL DAMAGE! PLEASE MAKE ALL WIRING CONNECTIONS AND NJ1 JUMPERS INSTALLATIONS BEFORE SWITCHING ON THE POWER.



Base on the FMA 5400A/5500A transducers model number it may require different power supply voltage: ether 12Vdc, 24Vdc or universal (any voltage between 12 and 26 Vdc). Before connecting power supply check controller power supply requirements label located on the controller back cover. If power supply requirements label states that power supply requirements is 12 Vdc, do not connect power supply with voltage above 15 Vdc. Exceeding specified maximum power supply voltage limit will result in device permanent damage.

The operating power input is supplied via the 15-pin “D” connector located at the side of the flow transducer enclosure. On FMA 5400A/5500A's purchased without an LCD readout, a readout panel meter, digital multimeter, or other equivalent device is required to facilitate visual flow readings.

A built in SETPOINT potentiometer is used for local control of the flow. Variable analog 0 to 5 Vdc (or 4 to 20 mA) reference input is required for remote control.

PIN FUNCTION

1	0 to 5 VDC Flow Signal Common
2	0 to 5 VDC Flow Signal Output
3	Common
4	Open (Purge)
5	Common, Power Supply
6	(unassigned)
7	+12 VDC (Optional +24 VDC*) Power Supply
8	Remote Setpoint Input
9	4 to 20 mA (-) Flow Signal Return (use with 14)
10	Remote Setpoint Common (use with 8)
11	+5VDC Reference Output for Remote Setpoint
12	Valve Off Control
13	Auxiliary +12 VDC (Optional +24 VDC*) Power Output (For Loads <100 mA)
14	4 to 20 mA (+) Flow Signal Output
15	Chassis Ground

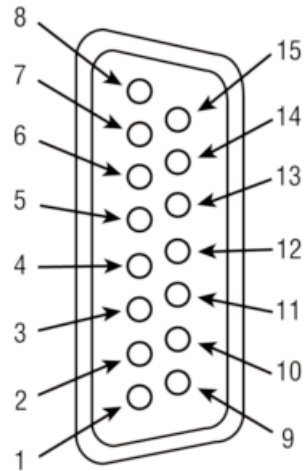

1 & 2	0-5 Vdc OUTPUT	5 & 7	+12 Vdc (Optional +24 Vdc*) POWER SUPPLY
3 & 4	PURGE	8 & 10	0-5 Vdc OR 4-20 mA REMOTE SETPOINT
3 & 12	VALVE OFF CONTROL	9 & 14	4-20 mA OUTPUT
5 & 13	AUXILIARY +12 Vdc (Optional +24 Vdc*) POWER OUTPUT (FOR LOADS <100 mA)	10 & 11	+5 Vdc CONTROL SOURCE

FIGURE 2-1 FMA 5400A/5500A 15-PIN “D” CONNECTOR CONFIGURATION

*Do not connect +24 Vdc power supply unless your FMA 5400A/5500A controller was ordered and configured for 24 Vdc



CAUTION: BEFORE CONNECTING THE POWER SUPPLY CHECK YOUR CONTROLLER MODEL NUMBER AND POWER SUPPLY REQUIREMENTS LABEL LOCATED ON THE CONTROLLER BACK COVER. DO NOT CONNECT 24 Vdc POWER SUPPLY UNLESS YOUR FMA 5400A/5500A CONTROLLER WAS ORDERED AND CONFIGURED FOR 24 Vdc. EXCEEDING THE SPECIFIED MAXIMUM POWER SUPPLY VOLTAGE LIMIT MAY RESULT IN PERMANENT DEVICE DAMAGE.

Important notes:

In general, “D” Connector numbering patterns are standardized. There are, however, some connectors with nonconforming patterns and the numbering sequence on your mating connector may or may not coincide with the numbering sequence shown in our pin configuration table above. It is imperative that you match the appropriate wires in accordance with the correct sequence regardless of the particular numbers displayed on your mating connector.

Power must be turned OFF when connecting or disconnecting any cables in the system.

The power input is protected by a 900mA (FMA 5400/5500 Series Max. Flow 10, 50, 100 L/min) or 1600mA (FMA 5400A/5500A Series Max. Flow 200, 500 and 1000 L/min) M (medium time-lag) resettable fuse. If a shorting condition or polarity reversal occurs, the fuse will cut power to the flow transducer circuit. Disconnect the power to the unit, remove the faulty condition, and reconnect the power. The fuse will reset once the faulty condition has been removed.



CAUTION: Fuse will not protect controller if power supply voltage exceeds maximum voltage specified for a particular model.

Use of the FMA 5400A/5500A flow transducer in a manner other than that specified in this manual or in writing from OMEGA®, may impair the protection provided by the equipment.

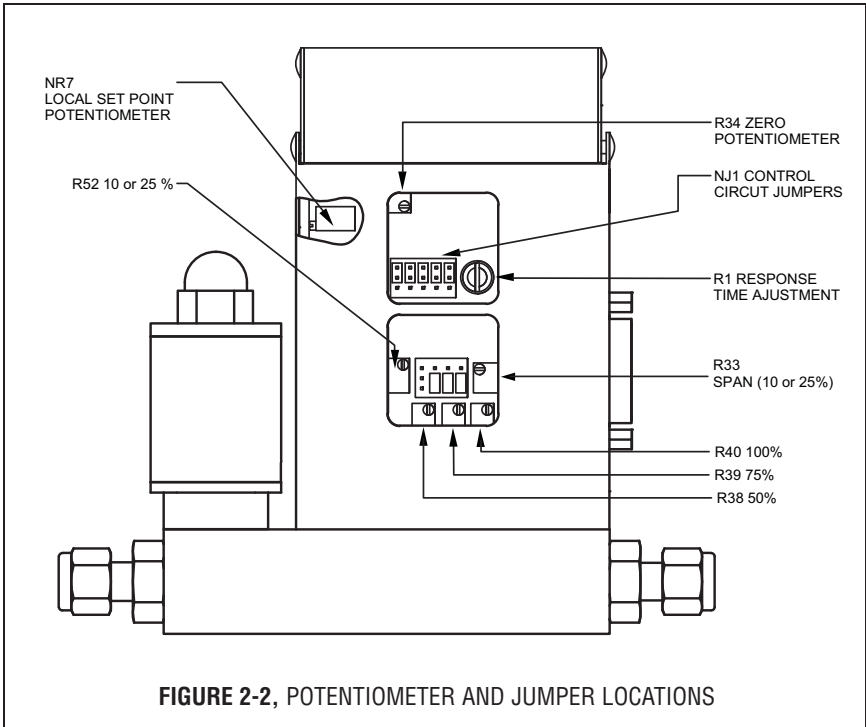

FIGURE 2-2, POTENTIOMETER AND JUMPER LOCATIONS

2.2.1 Valve Control Configuration

There are three basic valve control options.

- LOCAL or REMOTE control.
- 0 to 5 VDC or 4 to 20 mA setpoint signal -
***Note:** this only applies for the REMOTE control configuration;
- 2% cutoff active or not active. **Note:** 2% cutoff not available for FMA 200, 500 and 1000 L/min.

When active, the 2% cutoff will shut off the power to the valve when a setpoint of less than 2% of the full scale flow range is set. Figure 2-2 shows the jumper configurations for the three basic valve control options.

The factory default jumper settings are: LOCAL control, 2% cutoff off, and 0 to 5 VDC.

FUNCTION		NJ1A	NJ1B	NJ1C	NJ1D	NJ1E
Remote	0 to 5 Vdc 2% cutoff ON	2 - 3	5 - 6	8 - 9	10 - 11	13 - 14
	0 to 5 Vdc 2% cutoff OFF					14 - 15
	4 to 20 mA 2% cutoff ON	1 - 2	4 - 5	7 - 8	10 - 11	13 - 14
	4 to 20 mA 2% cutoff OFF					14 - 15
Local	2% cutoff ON	2 - 3	5 - 6	8 - 9	11 - 12	13 - 14
	2% cutoff OFF					14 - 15

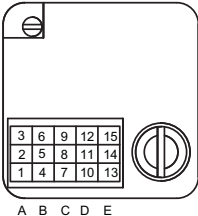

A B C D E

FIGURE 2-3, VALVE CONTROL CONFIGURATION JUMPERS

2.2.2 Remote LCD Readouts

FMA 5400A/5500A Mass Flow Controllers are available with optional remote reading LCD displays supplied with a three foot long wire to accommodate most applications. This configuration includes the upper block element which serves as the LCD readout mounting. Special lengths of remote extension wiring (up to 9.5 feet [3 meters]) are available on request.

2.2.3 Panel Mounting Readouts

Another option for the FMA 5400A/5500A Mass Flow Controller is the Panel Mounting Remote Readout.

In this configuration the LCD readout is supplied with a three foot long extension wire, and no aluminum housing around the LCD. The LCD readout for panel mounting includes a bezel with two plastic screws which conveniently fit into a rectangular cut-out for panel mounting (see Figure 2-3).

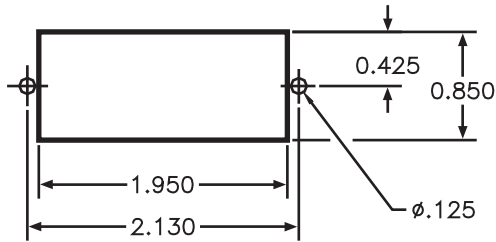

FIGURE 2-4 CUTOUT DIMENSIONS FOR LCD PANEL MOUNTING

3. PRINCIPLE OF OPERATION

The stream of gas entering the Mass Flow transducer is split by shunting a small portion of the flow through a capillary stainless steel sensor tube. The remainder of the gas flows through the primary flow conduit. The geometry of the primary conduit and the sensor tube are designed to ensure laminar flow in each branch. According to principles of fluid dynamics flow rates of gas in two properly sized laminar flow conduits are related to one another. Therefore, the flow rates measured in the sensor tube are directly proportional to the total flow through the transducer.

In order to sense the flow in the sensor tube, heat flux is introduced at two sections of the sensor tube by means of precision wound heater-sensor coils. Heat is transferred through the thin wall of the sensor tube to the gas flowing inside. As gas flow takes place heat is carried by the gas stream from the upstream coil to the downstream coil windings. The resultant temperature dependent resistance differential is detected electronically. The measured gradient at the sensor windings is linearly proportional to the instantaneous rate of flow taking place.

An output signal is generated that is a function of the amount of heat carried by the gases to indicate mass-molecular based flow rates.

FMA 5400A/5500A Mass Flow Controller Series Max. Flow 10, 50 and 100 L/min also incorporate a proportionating solenoid valve and Series Max. Flow 200, 500 and 1000 L/min a motorized valve. The closed loop control circuit of the FMA 5400A/5500A continuously compares the mass flow output with the selected flow rate. Deviations from the setpoint are corrected by compensating valve adjustments, thus maintaining the desired flow parameters.

4. SPECIFICATIONS

FLOW MEDIUM: Please note that FMA 5400A/5500A Mass Flow Controllers are designed to work with clean gases only. Never try to meter or control flow rates of liquids.

CALIBRATIONS: Supplied at Standard Conditions (14.7 psia and 70° F), or Normal Conditions (0 °C and 1.01 bar abs) unless otherwise requested or stated.

ENVIRONMENTAL (per IEC 664): Installation Level II; Pollution Degree II.

ACCURACY: FMA 5400/5500 Series Max. Flow 10, 50, 100 L/min: $\pm 1.0\%$ F.S.

FMA 5400A/5500A Series Max. Flow 200, 500 and 1000 L/min: See table below.

ACCURACY % FS			OPTIONAL ENHANCED ACCURACY % FS		
MODEL	FMA 5400A/5500A Series Max. Flow 200, 500 and 1000 L/min		MODEL	FMA 5400A/5500A Series Max. Flow 200, 500 and 1000 L/min	
FLOW RANGE	20-100%	0-20%	FLOW RANGE	20-100%	0-20%
ACCURACY	$\pm 1.5\%$	$\pm 3\%$	ACCURACY	$\pm 1\%$	REF DATA with $\pm 1\%$

REPEATABILITY: $\pm 0.5\%$ of full scale.

TEMPERATURE COEFFICIENT: 0.15% of full scale/ °C.

PRESSURE COEFFICIENT: 0.01% of full scale/psi (0.07 bar).

RESPONSE TIME: **FMA 5400A/5500A Series Max. Flow 10 L/min:** 300ms time constant; approximately 1 second to within $\pm 2\%$ of set flow rate for 25% to 100% of full scale flow.

FMA 5400A/5500A Series Max. Flow 50 & 100 L/min: 600ms time constant; approximately 2 seconds to within $\pm 2\%$ of set flow rate for 25% to 100% of full scale flow.

FMA 5400A/5500A Series Max. Flow 200, 500 & 1000 L/min: 1800ms time constant; approximately 5 seconds to within $\pm 2\%$ of set flow rate for 25% to 100% of full scale flow.

MAX GAS PRESSURE: 1000 psig (69 bars) FMA 5400A/5500A Series Max. Flow 10, 50 and 100 L/min; 500 psig (34.5 bars) Series Max. Flow 200, 500 & 1000 L/min. Optimum pressure is 20 psig (1.4 bars).

TURNDOWN RATIO: 40:1.

MAX DIFFERENTIAL PRESSURE: 50 psid (345 kPa).

GAS TEMPERATURE: 32 °F to 122 °F (0 °C to 50 °C).

AMBIENT TEMPERATURE: 14 °F to 122 °F (-10 °C to 50 °C).

GAS RELATIVE HUMIDITY: Up to 70%.

MAXIMUM INTERNAL LEAK: 0.5% FS.

LEAK INTEGRITY: 1×10^{-7} sccs He max to the outside environment.

ATTITUDE SENSITIVITY: No greater than ± 15 degree rotation from horizontal to vertical; standard calibration is in horizontal position.

OUTPUT SIGNALS: Linear 0 to 5 VDC (1000Ω minimum load impedance) and 4 to 20 mA (0 to 500Ω loop resistance); 20 mV peak to peak max noise for FMA 10, 50 and 100 L/min and 100 mV peak to peak max noise for FMA 200, 500 and 1000 L/min.

COMMAND SIGNAL: Analog 0 to 5 VDC ($100 K\Omega$ input impedance) or 4 to 20 mA (0 to 250Ω input impedance). **Contact OMEGA® for optional RS232 or IEEE488 interfaces.**

TRANSDUCER INPUT POWER:

FMA 5400A/5500A Series Max. Flow 200, 500 and 1000 L/min:

Models with 12 Vdc power input: 12 Vdc, 800 mA maximum;

FMA 5400A/5500A Series Max. Flow 200, 500 and 1000 L/min:

Models with 24 Vdc power input: 24 Vdc, 800 mA maximum;

FMA 5400A/5500A Series Max. Flow 10, 50, 100 L/min:

Models with universal power input:
any voltage between +12 and +26 Vdc, 650 mA maximum;

WETTED MATERIALS:

FMA 5400A/5500A Series Max. Flow 10, 50, 100, 200, 500 and 1000 L/min:

Anodized aluminum, brass, 416 Stainless Steel and 316 stainless steel with FKM O-rings seals; BUNA, EPR or Perfluoroelastomer O-rings are optional.

FMA 5400AST/5500AST Series Max. Flow 10, 50, 100, 200, 500 and 1000 L/min:

416 Stainless Steel and 316 stainless steel with FKM O-rings seals; BUNA, EPR or Perfluoroelastomer O-rings are optional.

OMEGA® makes no expressed or implied guarantees of corrosion resistance of mass flow meters as pertains to different flow media reacting with components of meters. It is the customers sole responsibility to select the model suitable for a particular gas based on the fluid contacting (wetted) materials offered in the different models.

INLET AND OUTLET CONNECTIONS:

FMA Series Max. Flow 10 and 50 L/min: 1/4" compression fittings.
Optional: 6mm compression, 1/4" VCR®,
3/8" or 1/8" compression fittings.

FMA Series Max. Flow 100 and 200 L/min: 3/8" compression fittings.

FMA Series Max. Flow 500 L/min: 1/2" compression fittings.

FMA Series Max. Flow 1000 L/min: 3/4" FNPT ports.
Optional: 3/4" compression fittings.

LCD DISPLAY: 3½ digit LCD (maximum viewable digits "1999", 0.5 inch high characters. On FMA 5400A/5500A aluminum or stainless steel models the LCD display is built into the

upper block element and may be tilted over 90 degrees for optimal viewing comfort. Remote or panel mounting remote reading is optional. Standard readings are in direct engineering units for the given gas and flow rate (i.e. liters/minute [slpm], standard cubic centimeters/minute [sccm], standard cubic feet/hour [scfh], etc.). 0 to 100% LCD calibration scaling is available upon request at time of order. Contact OMEGA® when non-standard display settings are desired.

TRANSDUCER INTERFACE CABLE: Optional shielded cable is available mating to the FMA 5400A/5500A transducer 15-pin “D” connector.

4.1 CE Compliance

FMA 5400A/5500A Mass Flow Controllers are in compliance with CE test standards stated below:

EMC Compliance with 89/336/EEC as amended; Emission Standard: EN 55011:1991, Group 1, Class B Immunity Standard: EN 55082-1:1992.

4.2 Flow Capacities

Table I
Low Flow
Mass Flow Controller*

CODE	mL/min [N ₂]	CODE	liters/min [N ₂]
02	0 to 10	14	0 to 1
04	0 to 20	16	0 to 2
06	0 to 50	18	0 to 5
08	0 to 100	20	0 to 10
10	0 to 200		
12	0 to 500		

Table II
Medium Flow
Mass Flow Controller*

CODE	liters/min [N ₂]
23	15
24	20
26	30
27	40
28	50

Table III
High Flow
Mass Flow Controller*

CODE	liters/min [N ₂]
40	60
41	80
42	100
43	200
44	500
45	1000

* Flow rates are stated for Nitrogen at STP conditions [i.e. 70 °F (21.1 °C) at 1 atm]. For other gases use the K factor as a multiplier from APPENDIX 2.

TABLE I PRESSURE DROPS

MAXIMUM FLOW RATE SERIES	FLOW RATE [liters/min]	MAXIMUM PRESSURE DROP		
		[mm H ₂ O]	[psid]	[mbar]
10 L/min	up to 10	720	1.06	75
50 L/min	15	2630	3.87	266
	20	1360	2.00	138
	30	2380	3.50	241
	40	3740	5.50	379
	50	5440	8.00	551
100 L/min	60	7480	11.00	758
	100	12850	18.89	1302
200 L/min	200	7031	10.00	690
500 L/min	500	8437	12.00	827
1000 L/min	1000	10547	15.00	1034

5. OPERATING INSTRUCTIONS

5.1 Preparation and Warm Up

It is assumed that the Mass Flow Controller has been correctly installed and thoroughly leak tested as described in section (2). Shut the flow source OFF. Apply power to the unit via the 15-pin “D” connector. Before connecting the power supply check the controller power supply requirements label located on the controller back cover. If the power supply requirements label states that power supply requirement is 12 Vdc, do not connect the power supply with voltage above 15 Vdc. Exceeding the specified maximum power supply voltage limit will result in device permanent damage. Allow the Mass Flow Controller to warm-up for at least 15 minutes.

During initial powering of the FMA 5400A/5500A transducer, the flow output signal will be indicating a higher than usual output. This is indication that the FMA 5400A/5500A transducer has not yet attained it's minimum operating temperature. This condition will automatically cancel within a few minutes and the transducer should eventually zero.

If after the 15 minutes warm-up period, the display still indicates a reading of less than ± 3.0 % of F.S., readjust the ZERO potentiometer [R34] through the access window. Before zero adjustment to temporarily disconnect the gas source, to ensure that no seepage or leak occurs in to the meter.



CAUTION: Adjusting Zero Reading more than $\pm 3.0\%$ F.S. from the factory settings may affect device calibration accuracy. If such adjustment is required it is recommended to perform controller recalibration to preserve device accuracy.

FMA Series Max. Flow 10, 50 and 100 L/min:



CAUTION: If the valve is left in the AUTO (control) or OPEN (PURGE) mode for an extended period of time, it may become warm or even hot to the touch. Use care in avoiding direct contact with the valve during operation.

Do not run FMA Series Max. Flow 10, 50 and 100 L/min models for extended periods of time with the valve in AUTO or PURGE mode without the flow of gas through the transducer. Doing so may result in up to 2% f.s. shift in calibration.

5.2 Flow Signal Output Readings

The flow signal output can be viewed on the LCD display, remote panel meter, digital multimeter, or other display device connected as shown in figure 2.1.

If an LCD display has been ordered with the FMA 5400A/5500A, the observed reading is in direct engineering units, for example, 0 to 10 scfm or 0 to 100 slpm (0 to 100% indication is optional). Engineering units for a specific FMA 5400A/5500A are shown on the flow transducer's front label.

Analog output flow signals of 0 to 5 VDC and 4 to 20 mA are available at the appropriate pins of the 15-pin "D" connector at the side of the FMA 5400A/5500A transducer (see Figure 2-1).

Meter signal output is linearly proportional to the mass molecular flow rate of the gas being metered. The full scale range and gas for which your meter has been calibrated are shown on the flow transducer's front label.

Default calibration is performed for 0 to 5 VDC input/output signal. If 4-20 mA output signal is used for flow indication on the FMA 5400A/5500A, which was calibrated against 0 to 5 VDC input signal, the accuracy of the actual flow rate will be in the specified range ($\pm 1.0\%$ FMA 5400A/5500A 17, 37, 47. $\pm 1.5\%$ FMA 5400A/5500A 57, 67, 77) of full scale, but the total uncertainty of the output reading may be in the range of $\pm 2.5\%$ of full scale. Optional calibration for 4-20 mA output signal is available upon request at time of order.

For optional RS232 or RS485 IEEE488 interfaces please contact OMEGA®.

5.3 Swamping Condition

If a flow of more than 10% above the maximum flow rate of the Mass Flow Controller is taking place, a temporary condition known as "swamping" may occur. Readings of a "swamped" meter cannot be assumed to be either accurate or linear. Flow must be restored to below 110% of maximum meter range. Once flow rates are lowered to within calibrated range, the swamping condition will end. Operation of the meter above 110% of maximum calibrated flow may increase recovery time.

5.4 Setpoint Reference Signal

FMA 5400A/5500A flow controllers have built-in solenoid valve (FMA Series Max. Flow 10, 50 and 100 L/min), or motorized valves (FMA Series Max. Flow 200, 500 and 1000 L/min) allow the user to set the flow to any desired flow rate within the range of the particular model installed. The solenoid valve is normally closed (NC) when no power is applied.

The motorized valve can be in any position depending on the operation mode of the FMA 5400A/5500A during disconnecting of the power. power is applied for the For example if the motorized valve was left in the OPEN purge position after disconnecting power from the FMA 5400A/5500A it will be in the OPEN position. It is the customers responsibility to provide a solution to shut down the flow in case of a power outage. When power is applied to FMA Series Max. Flow 200, 500 and 1000 L/min models, the valve automatically closes within the first ten seconds regardless of the set point and valve override signals.

Setpoints are controlled locally or remotely. Setpoints inputs respond to analog 0 to 5 VDC or 4 to 20 mA reference voltages (default jumper setting is 0 to 5 VDC). Voltage is a linear representation of 0 to 100% of the full scale mass flow rate. Response times to setpoint changes are 1 second (FMA Series Max. Flow 10 L/min), 2 seconds (FMA Series Max. Flow 50 and 100 L/min) and 5 seconds (FMA 200, 500 and 1000 L/min) within 2% of the final flow over 25 to 100% of full scale.

For LOCAL flow control, use the built-in setpoint potentiometer located at the same side as the solenoid valve of the FMA 5400A/5500A transducer. While applying flow to the transducer, adjust the setpoint with an insulated screwdriver until the flow reading is the same as the desired control point. [The display will only show actual instantaneous flow rate. There is no separate display for setpoints.]

For REMOTE control of the FMA 5400A/5500A, an analog reference signal must be supplied. On pin [11] of the FMA 5400A/5500A transducer is a regulated and constant +5VDC output signal. This signal may be used in conjunction with a local setpoint potentiometer for flow setting.

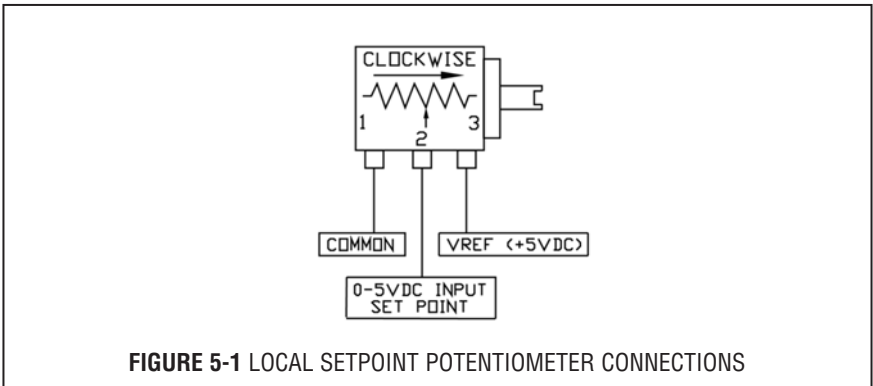

FIGURE 5-1 LOCAL SETPOINT POTENTIOMETER CONNECTIONS

It is recommended that a potentiometer between 5K to 100K ohm and capable of at least 10-turns or more for adjustment be used. Use the control potentiometer to command the percentage of flow desired.

Alternatively, a variable 0 to 5VDC or 4 to 20 mA analog signal may be applied directly to the SETPOINT and COMMON connections of the FMA 5400A/5500A transducer (see Figure 2-1). Be sure to apply the appropriate signal for the designated jumper settings.

5.5 Valve OFF Control (Open Collector NPN Compatible)

It may be necessary or desirable to set the flow and maintain that setting while being able to turn the flow control valve off and on again. Closing of the valve (without changing the setpoint adjustment) can be accomplished by connecting pin [12] of the 15-pin “D” connector to COMMON pin [3]. When pin [12] is connected to COMMON, the solenoid valve is not powered and therefore will remain normally closed regardless of the setpoint. The Motorized valve will be given the command to close indicated by a green light on top of the unit).

Conversely, when the connection is left open or pin [12] remains unconnected the valve remains active. The valve will remain active when the VALVE OFF pin remains “floating”. This feature is compatible with open collector NPN transistor switches, as found in DC output ports of programmable controllers and similar devices.

The simplest means for utilizing the VALVE OFF control feature, is to connect a toggle switch between the COMMON and VALVE OFF pins of the FMA 5400A/5500A transducer. Toggling the switch on and off will allow for activating and deactivating the solenoid valve.

5.6 Valve Test/Purge

At times, it may be necessary to purge the flow system with a neutralizing gas such as pure dry nitrogen. The FMA 5400A/5500A transducer is capable of a full open condition for the valve, regardless of setpoint conditions. Connecting the OPEN (PURGE) pin (pin [4] on 15-pin “D” connector) to ground will fully open the valve.

The Motorized Valve: Connect pins [3] and [4] to OPEN the motorized control valve A red light on top of the valve will indicated an OPEN valve condition, normal for flow conditions.



NOTE: The motorized control valve stays OPEN even if power is no longer applied. To CLOSE the Motorized Control Valve, connect pins [3] and [12].

6. MAINTENANCE

6.1 Introduction

It is important that the Mass Flow Controller/Controller is used with clean, filtered gases only. Liquids may not be metered. Since the RTD sensor consists, in part, of a small capillary stainless steel tube, it is prone to occlusion due to impediments or gas crystallization. Other flow passages are also easily obstructed. Therefore, great care must be exercised to avoid the introduction of any potential flow impediment. To protect the instrument a 50 micron (FMA Series Max. Flow 10 L/min) or 60 micron (FMA Series Max. Flow 50 and 100 L/min) filter is built into the inlet of the flow transducer. The filter screen and the flow paths may require occasional cleaning as described below. There is no other recommended maintenance required. It is good practice, however, to keep the meter away from vibration, hot or corrosive environments and excessive RF or magnetic interference.

If periodic calibrations are required they should be performed by qualified personnel and calibrating instruments, as described in section (7). It is recommended that units are returned to OMEGA® for repair service and calibration.



CAUTION: TO PROTECT SERVICING PERSONNEL IT IS MANDATORY THAT ANY INSTRUMENT BEING SERVICED IS COMPLETELY PURGED AND NEUTRALIZED OF TOXIC, BACTERIOLOGICALLY INFECTED, CORROSIVE OR RADIOACTIVE CONTENTS.

6.2 Flow Path Cleaning

Inspect visually the flow paths at the inlet and outlet ends of the meter for any debris that may be clogging the flow through the meter. Remove debris carefully using tweezers and blowing low pressure clean air or Nitrogen from the inlet side. If the flow path is not unclogged, please return to Omega® for servicing.



Do not attempt to disassemble the sensor. Disassembly will invalidate calibration.

6.2.1 **Cleaning the Inlet Filter Screen in FMA 5400A/5500A Series Max. Flow 10**

Unscrew the inlet compression fitting of meter. Note that the Restrictor Flow Element (RFE) is connected to the inlet fitting.

The Restrictor Flow Element (RFE) is a precision flow divider inside the transducer, which splits the inlet gas flow by a fixed ratio to the sensor and main flow paths. The particular RFE used in a given Mass Flow Controller depends on the gas and flow range of the instrument.

Carefully disassemble the RFE from the inlet connection. The 50 micron filter screen will now become visible. Push the screen out through the inlet fitting. Clean or replace each of the removed parts as necessary.

If alcohol is used for cleaning, allow time for drying before re-assembling. Carefully re-install the RFE and inlet fitting, avoiding any twisting and deforming the RFE. Be sure that no dust has collected on the O-ring seal.



NOTE: Over tightening will deform and render the RFE defective.

It is advisable that at least one calibration point be checked after re installing the inlet fitting - see section (7).



IT IS NOT RECOMMENDED TO ATTEMPT TO DISASSEMBLE, OR REPAIR FMA SERIES MAX. FLOW 50, 100, 200, 500 and 1000 L/min. DISASSEMBLY NECESSITATES RE-CALIBRATION.

6.2.2 Valve Maintenance for FMA Series Max. Flow 10/50/100 L/min.

The solenoid valve consists of 316 and 416 stainless steel, and VITON® (or optional EPR or KALREZ®) O-rings and seal materials. No regular maintenance is required except for periodic cleaning.

It is advisable that at least one calibration point be checked after re-installing the inlet fitting - see section (7).

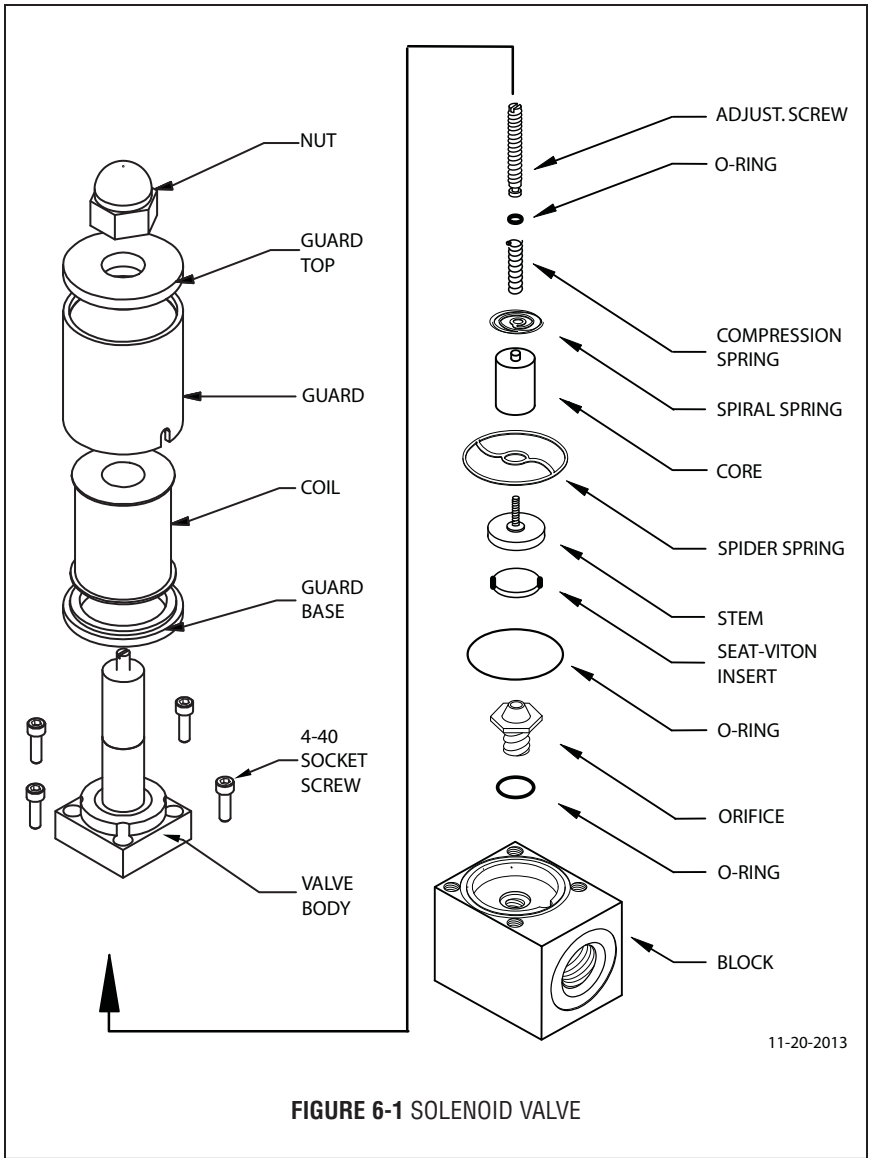

FIGURE 6-1 SOLENOID VALVE

11-20-2013

Various corrosive gases may demand more frequent replacement of FKM O-rings and seals inside the valve. Be sure to use an elastomer material, appropriate for your specific gas application. Contact OMEGA® for optional sealing materials available.

Set the FMA 5400A/5500A into PURGE mode (see Figure 2-1), and attempt to flush through with a clean, filtered, and neutral gas such as nitrogen. [Another option for fully opening the valve is to remove the plastic cap on top of the valve, and turning the set screw counterclockwise until it stops. See section 7.3 for valve adjustment, to return the valve to functional use.]

7. CALIBRATION PROCEDURES



NOTE: Removal of the factory installed calibration seals and/or any adjustments made to the meter, as described in this section, will void any calibration warranty applicable.

7.1 Flow Calibration

OMEGA® Engineering Flow Calibration Laboratory offers professional calibration support for Mass Flow Meter and Controllers, using precision calibrators under strictly controlled conditions. NIST traceable calibrations are available. Calibrations can also be performed by customers using available certified standards.

Factory calibrations are performed using state of the art NIST traceable precision volumetric calibrators.

Calibrations are performed using dry nitrogen gas. Calibration can then be corrected to the appropriate gas desired based on relative correction [K] factors shown in the gas factor table - see Appendix 2. A reference gas, other than nitrogen, may be used to approximate the flow characteristics of certain gases closer. This practice is recommended when a reference gas is found with thermodynamic properties similar to the actual gas under consideration. The appropriate relative correction factor should be recalculated - see section (9).

It is standard practice to calibrate Mass Flow Controllers with dry nitrogen gas. It is best to calibrate the FMA Series Max. Flow 100 L/min transducers to actual operating conditions. Specific gas calibrations of non-toxic and non-corrosive gases are available at specific conditions. Please contact OMEGA® for a price quotation.

It is recommended that a flow calibrator of at least four times better collective accuracy than that of the Mass Flow Controller to be calibrated be used. Equipment required for calibration includes a flow calibration standard and a certified high sensitivity multimeter (which together have a collective accuracy of $\pm 0.25\%$ or better), an insulated (plastic) screwdriver, a flow regulator (example: metering needle valve) installed upstream from the Mass Flow Controller and a pressure regulated source of dry filtered nitrogen gas (or other suitable reference gas).

The gas and ambient temperature, as well as inlet and outlet pressure conditions should be set up in accordance with actual operating conditions.

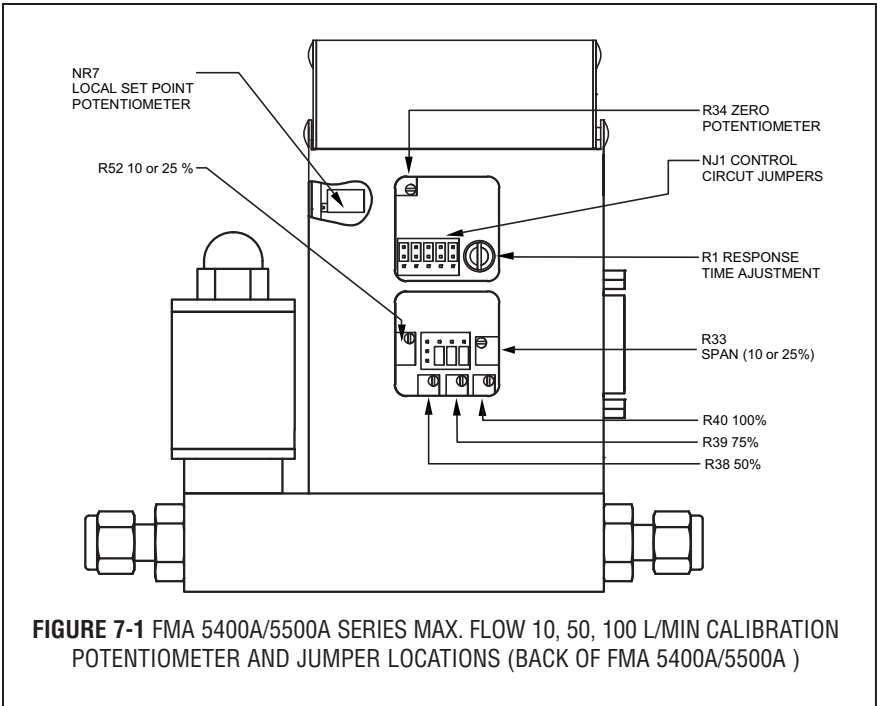

7.2 Calibration of FMA 5400A/5500A Series Max. Flow 10, 50, 100 L/min Mass Flow Controllers

All adjustments in this section are made from the outside of the meter, there is no need to disassemble any part of the instrument.

FMA 5400A/5500A Mass Flow Controllers may be field recalibrated/checked for the same range they were originally factory calibrated for. When linearity adjustment is needed, or flow range changes are being made proceed to step 7.2.4. Flow range changes may require a different Restrictor Flow Element (RFE). Additionally, a different Solenoid Valve Orifice may also be required (see Table VI). Consult OMEGA® for more information.

7.2.1 Connections and Initial Warm Up

At the 15-pin “D” connector of the FMA 5400A/5500A transducer, connect the multimeter to output pins [1] and [2] for 0 to 5 VDC (or pins [9] and [14] for 4 to 20 mA) - (see Figure 2-1).

When using a remote setpoint for flow control, the appropriate reference signal should also be connected to the 15-pin “D” connector at pins [8] and [10] - (see Figure 2-1). Power up the Mass Flow Controller for at least 30 minutes prior to commencing the calibration procedure.

7.2.2 ZERO Adjustment

Shut off the flow of gas into the Mass Flow Controller. To ensure that no seepage or leak occurs into the meter, temporarily disconnect the gas source.

Using the multimeter and the insulated screwdriver, adjust the ZERO potentiometer [R34] through the access window for 0 Vdc (or 4 mA respectively) at zero flow.

7.2.3 SPAN Adjustment

Reconnect the gas source. Adjust the control setpoint to 100% of full scale flow. Check the flow rate indicated against the flow calibrator. If the deviation is less than $\pm 10\%$ of full scale reading, correct the SPAN potentiometer [R33] setting by using the insulated screwdriver through the access window, to eliminate any deviation. If the deviation is larger than $\pm 10\%$ of full scale reading, a defective condition may be present.

LIKELY REASONS FOR A MALFUNCTIONING SIGNAL MAY BE:

- ✓ Occluded or contaminated sensor tube.
- ✓ Leaking condition in the FMA 5400A/5500A transducer or the gas line and fittings.
- ✓ For gases other than nitrogen, recheck appropriate "K" factor from Gas Factor Table.
- ✓ Temperature and/or pressure correction errors.

See also section (8) TROUBLESHOOTING. If after attempting to remedy the above conditions, a malfunction still persists, return the meter for factory service, see section (1).

At this point the calibration is complete. However, it is advisable that several additional points between 0 and 100%, such as 25%, 50%, and 75% flow be checked. If discrepancies are found, proceed to step 7.2.4 for Linearity Adjustment.

7.2.4 Linearity Adjustment

All adjustments in this section are made from the outside of the meter, there is no need to disassemble any part of the instrument.

7.2.4.1 Disable Solenoid Valve in FMA 5400A/5500A Series Max. Flow 10, 50, 100 L/min

Set the valve into PURGE mode. This step essentially bypasses the flow control properties of the transducer. The unit will now act as a Mass Flow Meter.



CAUTION: FOR FMA 5400A/5500A Series Max. Flow 10, 50, 100 L/min- If the valve is left in the AUTO (control) or OPEN (PURGE) mode for an extended period of time, it may become warm or even hot to the touch. Use care in avoiding direct contact with the valve during operation.

7.2.5 Connections and Initial Warm Up

Connect the multimeter to output pins [1] and [2] for 0 to 5 VDC (or pins [9] and [14] for 4 to 20 mA) of the 15-pin "D" connector - (see Figure 2-1).

If calibration to a new flow range or different gas is being performed, it may be necessary to remove any jumpers at J1A, J1B, J1C and J1D before beginning linearizing procedure.

Power up the Mass Flow Controller for at least 30 minutes prior to commencing the calibration procedure.

7.2.6 ZERO Adjustment

Shut off the flow of gas into the Mass Flow Controller. To ensure that no seepage or leak occurs into the meter, it is good practice to temporarily disconnect the gas source.

Using the multimeter and the insulated screwdriver, adjust the ZERO LCD reading and 0 Vdc (or 4 mA respectively) analog output reading at zero flow by adjusting the zero potentiometer [R34] through the access window.



CAUTION: The minimum voltage on 0-5 Vdc output can be in the range of 7 to 25 mV. Trying to reduce voltage below this level may increase negative zero shift. This shift may be invisible on devices without LCD display. Stop R34 zero potentiometer adjustment if voltage on 0-5 Vdc output is in the range from 7 to 25 mV and does not decrease any lower.

7.2.7 25% Flow Adjustment

Reconnect the gas source. Using the flow regulator, adjust the flow rate to 25% of full scale flow. Check the flow rate indicated against a flow calibrator. Adjust the setting for potentiometer [R33] by using the insulated screwdriver through the access window, until the output of the flow meter reads 1.25VDC \pm 63mV (or 8mA \pm 0.25mA).

Using the flow regulator, adjust the flow rate until the output of the flow meter reads 0.5 Vdc (or 5.6mA). Check the flow rate against the flow calibrator. If the flow rate indicated by the calibrator is within 10% \pm 1.5% of F.S. then skip paragraphs 7.2.8, 7.2.9 and proceed directly to paragraph 7.2.10, if not, perform 10% flow adjustment according to paragraph 7.2.8.

LINEARIZER FUNCTION	J1A (10 or 25%)	J1B (50%)	J1C (75%)	J1D (100%)
Decrease	1 - 2	4 - 5	7 - 8	10 - 11
Increase	2 - 3	5 - 6	8 - 9	11 - 12

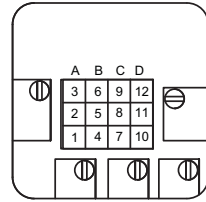

FIGURE 7-2 FMA 5400A/5500A SERIES MAX. FLOW 10, 50, 100 L/min CALIBRATION POTENTIOMETER AND JUMPERS

7.2.8 10% Flow Adjustment

Using the flow regulator, adjust the flow rate to 10% of full scale flow according to the calibrator. Check the flow rate indicated against the flow calibrator. Adjust the setting for potentiometer [R33] by using the insulated screwdriver through the access window, until the output of the flow meter reads 0.5 Vdc \pm 63mV (or 5.6mA \pm 0.25mA).

7.2.9 25% Flow Adjustment (using R52 potentiometer)

Using the flow regulator, adjust the flow rate to 25% of full scale flow according to the calibrator. Check the flow rate indicated against the flow calibrator. The output of the flow meter should read 1.25 Vdc \pm 63mV (or 8.0mA \pm 0.25mA). If the reading is outside of that range, place the jumper at [J1.A] as appropriate to increase or decrease the signal. Adjust the setting for potentiometer [R52] by using the insulated screwdriver through the access window, until reading is within specification.

7.2.10 50% Flow Adjustment

Using the flow regulator, increase the flow rate to 50% of full scale flow. Check the flow rate indicated against the flow calibrator. The output of the flow meter should read 2.50 Vdc \pm 63mV (or 12mA \pm 0.25mA). If the reading is outside of that range, place the jumper at [J1B] as appropriate to increase or decrease the signal. Adjust the setting for potentiometer [R38] by using the insulated screwdriver through the access window, until reading is within specification.

7.2.11 75% Flow Adjustment

Using the flow regulator, increase the flow rate to 75% of full scale flow. Check the flow rate indicated against the flow calibrator. The output of the flow meter should read 3.75 Vdc \pm 63mV (or 16mA \pm 0.25mA). If the reading is outside of that range, place the jumper at [J1C] as appropriate to increase or decrease the signal. Adjust the setting for potentiometer [R39] by using the insulated screwdriver through the access window, until reading is within specification.

7.2.12 100% Flow Adjustment

Using the flow regulator, increase the flow rate to 100% of full scale flow. Check the flow rate indicated against the flow calibrator. The output of the flow meter

should read 5.00VDC \pm 63mV (or 20mA \pm 0.25mA). If the reading is outside of that range, place the jumper at [J1C] as appropriate to increase or decrease the signal. Adjust the setting for potentiometer [R40] by using the insulated screwdriver through the access window, until reading is within specification.

Repeat steps 7.2.7 to 7.2.10 at least once more.

7.2.13 VALVE ADJUSTMENT

7.2.13.1 Valve Adjustment for FMA Series Max. Flow 10, 50 and 100 L/min

Discontinue the PURGE mode (set valve for the closed position). Apply an inlet pressure of 5 psig, and atmospheric pressure at the outlet. If a small flow occurs, turn the set screw on top of the solenoid valve clockwise until the flow through the FMA 5400A/5500A just stops.

7.2.14 Close Loop Full Scale Flow Adjustment

Fully open the flow regulator upstream of the FMA 5400A/5500A. Increase the inlet pressure to 20 psig (25 psig for FMA Series Max. Flow 100 L/min). Apply a +5.00 VDC (100% full scale flow) setpoint reference. Using the calibrator check the flow rate. If necessary, adjust R33 to match the desired full scale flow rate. [In control mode, turning R33 clockwise will decrease the flow. Conversely, turning R33 counterclockwise will increase the flow through the FMA 5400A/5500A.]

7.2.15 10% Close Loop Flow Adjustment (using R33 potentiometer)

If the J1A jumper is not installed in upper or lower position (paragraphs 7.2.8 and 7.2.9 were skipped) then skip this paragraph and paragraph 7.2.16. Proceed directly to paragraph 7.2.17. Change the setpoint to 0.5 Vdc to control at 10% of full scale flow. Check the flow rate indicated against the flow calibrator. If the flow rate is not within \pm 0.75% of full scale, re-adjust the setting for potentiometer [R33], until the flow output is correct.

7.2.16 25% Close Loop Flow Adjustment (using R52 potentiometer)

Change the setpoint to 1.25 Vdc to control at 25% of full scale flow. Check the flow rate indicated against the flow calibrator. If the flow rate is not within \pm 0.75% of full scale, re-adjust the setting for potentiometer [R52], until the flow output is correct.

7.2.17 Close Loop 25% Flow Adjustment (using R33 potentiometer)

Change the setpoint to 1.25 VDC to control at 25% of full scale flow. Check the flow rate indicated against the flow calibrator. If the flow rate is not within \pm 0.75% of full scale, re-adjust the setting for potentiometer [R33], until the flow output is correct.

7.2.18 Close Loop 50% Flow Adjustment

Change the setpoint to 2.50 VDC to control at 50% of full scale flow. Check the flow rate indicated against the flow calibrator. If the flow rate is not within $\pm 0.75\%$ of full scale, re-adjust the setting for potentiometer [R38], until the flow output is correct.

7.2.19 Close Loop 75% Flow Adjustment

Change the setpoint to 3.75 VDC to control at 75% of full scale flow. Check the flow rate indicated against the flow calibrator. If the flow rate is not within $\pm 0.75\%$ of full scale, re-adjust the setting for potentiometer [R39], until the flow output is correct.

7.2.20 Close Loop 100% Flow Adjustment

Change the setpoint to 5.00 VDC to control at 100% of full scale flow. Check the flow rate indicated against the flow calibrator. If the flow rate is not within $\pm 0.75\%$ of full scale, re-adjust the setting for potentiometer [R40], until the flow output is correct.

Repeat steps 7.2.15 to 7.2.20 at least once more.

ORIFICE PART NUMBER	FLOW RATE [N ₂]
OR.020	10 to 1000 sccm
OR.040	1 to 5 slpm
OR.055	5 to 10 slpm
OR.063	10 to 15 slpm
OR.094	20 to 50 slpm
OR.125	50 to 100 slpm

TABLE II FMA 5400A/5500A SOLENOID VALVE ORIFICE SELECTION TABLE

7.3 Calibration of FMA 5400A/5500A Series Max. Flow 200, 500 and 1000 L/min Mass Flow Controllers

All adjustments in this section are made from the outside of the meter, there is no need to disassemble any part of the instrument. FMA 5400A/5500A Mass Flow Controllers may be field recalibrated/checked for the same range they were originally factory calibrated for. When linearity adjustment is needed, or flow range changes are being made proceed to step 7.2.4. Flow range changes may require a different Restrictor Flow Element (RFE). Additionally, a different Solenoid Valve Orifice may also be required (see Table VI). Consult Omega® for more information.

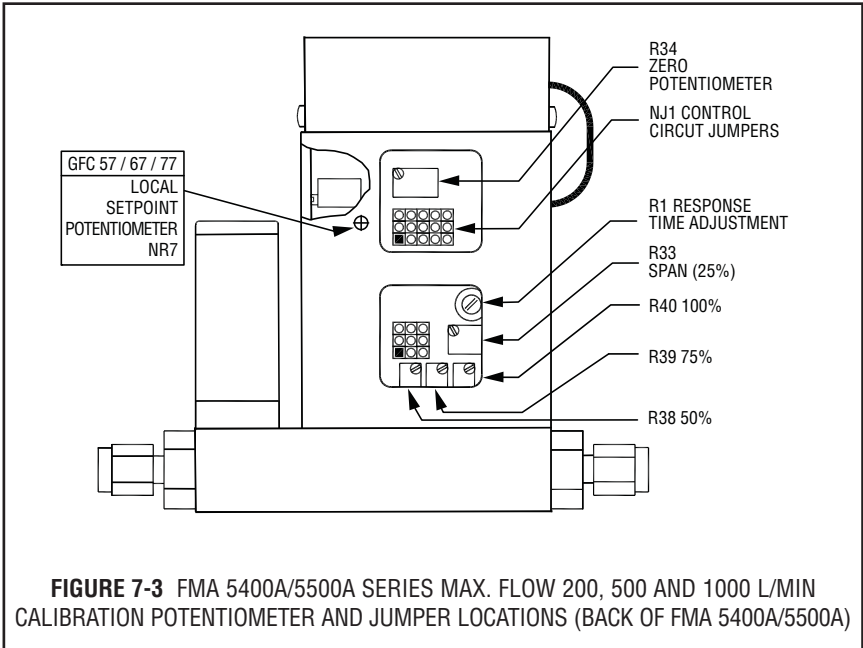

FIGURE 7-3 FMA 5400A/5500A SERIES MAX. FLOW 200, 500 AND 1000 L/MIN CALIBRATION POTENTIOMETER AND JUMPER LOCATIONS (BACK OF FMA 5400A/5500A)

7.3.1 Connections and Initial Warm Up

At the 15-pin “D” connector of the FMA 5400A/5500A transducer, connect the multimeter to output pins [1] and [2] for 0 to 5 Vdc (or pins [9] and [14] for 4 to 20 mA) - (see Figure 2-1). When using a remote setpoint for flow control, the appropriate reference signal should also be connected to the 15-pin “D” connector at pins [8] and [10] - (see Figure 2-1). Power up the Mass Flow Controller for at least 30 minutes prior to commencing the calibration procedure.

7.3.2 ZERO Adjustment

Shut off the flow of gas into the Mass Flow Controller. To ensure that no seepage or leak occurs into the meter, temporarily disconnect the gas source. Using the multimeter and the insulated screwdriver, adjust the ZERO potentiometer [R34] through the access window for 0 Vdc (or 4 mA respectively) at zero flow.

7.3.3 SPAN Adjustment

Reconnect the gas source. Adjust the control setpoint to 100% of full scale flow. Check the flow rate indicated against the flow calibrator. If the deviation is less than $\pm 10\%$ of full scale reading, correct the SPAN potentiometer [R33] setting by using the insulated screwdriver through the access window, to eliminate any deviation. If the deviation is larger than $\pm 10\%$ of full scale reading, a defective condition may be present.

LIKELY REASONS FOR A MALFUNCTIONING SIGNAL MAY BE:

- ✓ Occluded or contaminated sensor tube.
- ✓ Leaking condition in the FMA 5400A/5500A transducer or the gas line and fittings.
- ✓ For gases other than nitrogen, recheck appropriate “K” factor from Gas Factor Table.
- ✓ Temperature and/or pressure correction errors.

See also section (8) TROUBLESHOOTING. If after attempting to remedy the above conditions, a malfunction still persists, return the meter for factory service, **see section (1)**. At this point the calibration is complete. However, it is advisable that several additional points between 0 and 100%, such as 25%, 50%, and 75% flow be checked. If discrepancies are found, proceed to step 7.3.4 for Linearity Adjustment.

7.3.4 Linearity Adjustment

All adjustments in this section are made from the outside of the meter, there is no need to disassemble any part of the instrument.

7.3.4.1 Open Motorized Valve in FMA 5400A/5500A Series Max. Flow 200, 500 and 1000 L/min

Set the valve to PURGE mode by connecting pin [4] to pin [3], at the 15 pin D-connector.

7.3.5 Connections and Initial Warm Up

Connect the multimeter to output pins [1] and [2] for 0 to 5 Vdc (or pins [9] and [14] for 4 to 20 mA) of the 15-pin “D” connector - (see Figure 2-1). If calibration to a new flow range or different gas is being performed, it may be necessary to remove any jumpers at J1A, J1B, and J1C before beginning linearizing procedure.

Power up the Mass Flow Controller for at least 30 minutes prior to commencing the calibration procedure.

7.3.6 ZERO Adjustment

Shut off the flow of gas into the Mass Flow Controller. To ensure that no seepage or leak occurs into the meter, it is good practice to temporarily disconnect the gas source. Using the multimeter and the insulated screwdriver, adjust the ZERO potentiometer [R34] through the access window for 0 Vdc (or 4 mA respectively) at zero flow.

7.3.7 25% Flow Adjustment

Reconnect the gas source. Using the flow regulator, adjust the flow rate to 25% of full scale flow. Check the flow rate indicated against the flow calibrator. Adjust the setting for potentiometer [R33] by using the insulated screwdriver through the access window, until the output of the flow meter reads 1.25 Vdc \pm 63mV (or 8mA \pm 0.25mA).

LINEARIZER FUNCTION	J1A (50%)	J1B (75%)	J1C (100%)
Decrease	1 - 2	4 - 5	7 - 8
Increase	2 - 3	5 - 6	8 - 9

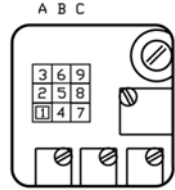

FIGURE 7-4 FMA 5400A/5500A SERIES MAX. FLOW 200, 500 AND 1000 L/MIN CALIBRATION POTENTIOMETER AND JUMPERS

7.3.8 50% Flow Adjustment

Using the flow regulator, increase the flow rate to 50% of full scale flow. Check the flow rate indicated against the flow calibrator. The output of the flow meter should read 2.50 Vdc \pm 63mV (or 12mA \pm 0.25mA). If the reading is outside of that range, place the jumper at [J1A] as appropriate to increase or decrease the signal. Adjust the setting for potentiometer [R38] by using the insulated screwdriver through the access window, until reading is within specification.

7.3.9 75% Flow Adjustment

Using the flow regulator, increase the flow rate to 75% of full scale flow. Check the flow rate indicated against the flow calibrator. The output of the flow meter should read 3.75 Vdc \pm 63mV (or 16mA \pm 0.25mA). If the reading is outside of that range, place the jumper at [J1B] as appropriate to increase or decrease the signal. Adjust the setting for potentiometer [R39] by using the insulated screwdriver through the access window, until reading is within specification.

7.3.10 100% Flow Adjustment

Using the flow regulator, increase the flow rate to 100% of full scale flow. Check the flow rate indicated against the flow calibrator. The output of the flow meter should read 5.00 Vdc \pm 63mV (or 20mA \pm 0.25mA). If the reading is outside of that range, place the jumper at [J1C] as appropriate to increase or decrease the signal. Adjust the setting for potentiometer [R40] by using the insulated screwdriver through the access window, until reading is within specification. Repeat steps 7.2.7 to 7.2.10 at least once more.

7.3.11. VALVE ADJUSTMENT

7.3.11.1 Valve Adjustment for FMA 5400A/5500A Series Max. Flow 200, 500 and 1000 L/min

Discontinue the PURGE mode (set valve for the Auto position). **DO NOT** adjust the motorized valve for FMA 5400A/5500A Series Max. Flow 200, 500 and 1000 L/min. The motorized valve for these models has been pre-adjusted at the factory.

7.3.12 Full Scale Flow Adjustment

Fully open the flow regulator upstream of the FMA 5400A/5500A. Increase the inlet pressure to 20 psig. Apply a +5.00 Vdc (100% full scale flow) setpoint reference. Using the calibrator check the flow rate. If necessary, adjust R33 to match the desired full scale flow rate. [In control mode, turning R33 clockwise will decrease the flow. Conversely, turning R33 counterclockwise will increase the flow through the FMA 5400A/5500A.]

7.3.13 25% Flow Adjustment

Change the setpoint to 1.25 Vdc to control at 25% of full scale flow. Check the flow rate indicated against the flow calibrator. If the flow rate is not within $\pm 0.75\%$ of full scale, re-adjust the setting for potentiometer [R33], until the flow output is correct.

7.3.14 50% Flow Adjustment

Change the setpoint to 2.50 Vdc to control at 50% of full scale flow. Check the flow rate indicated against the flow calibrator. If the flow rate is not within $\pm 0.75\%$ of full scale, re-adjust the setting for potentiometer [R38], until the flow output is correct.

7.3.15 75% Flow Adjustment

Change the setpoint to 3.75 Vdc to control at 75% of full scale flow. Check the flow rate indicated against the flow calibrator. If the flow rate is not within $\pm 0.75\%$ of full scale, re-adjust the setting for potentiometer [R39], until the flow output is correct.

7.3.16 100% Flow Adjustment

Change the setpoint to 5.00 Vdc to control at 100% of full scale flow. Check the flow rate indicated against the flow calibrator. If the flow rate is not within $\pm 0.75\%$ of full scale, re-adjust the setting for potentiometer [R40], until the flow output is correct.

Repeat steps 7.3.13 to 7.3.16 at least once more.

7.4 LCD Display Scaling

It may be desirable to re-scale the output reading on the LCD readout supplied with certain model FMA 5400A/5500A transducers. Re-calibration for a new flow range or different engineering units are two examples of when this may be necessary.

7.4.1 Access LCD Display Circuit

Carefully remove the LCD from the FMA 5400A/5500A or panel mounted surface. Remove the aluminum housing on the side of the connection cable. Slide the LCD assembly out of the aluminum housing.

7.4.2 Adjust Scaling

Using a digital multimeter connected to either the 0 to 5 VDC or 4 to 20 mA signal at the 15-pin “D” connector, set the flow rate on the FMA 5400A/5500A to full scale flow (5 VDC or 20mA). Maintain full scale flow, and adjust the potentiometer [R3] on the LCD printed circuit board to desired full scale flow reading.

7.4.3 Change Decimal Point

To change the decimal place on the LCD display readout, simply move the jumper to the appropriate location on the 8-pin header block. The numbers are printed to the side of the connections. Do not attempt to place more than one jumper for decimal setting.

JUMPER POSITION	MAXIMUM SCALABLE DISPLAY READING
“0”	1999
“3”	199.9
“2”	19.99
“1”	1.999

8. TROUBLESHOOTING

8.1 Common Conditions

Your Mass Flow Controller/Controller was thoroughly checked at numerous quality control points during and after manufacturing and assembly operations. It was calibrated in accordance to your desired flow and pressure conditions for a given gas or a mixture of gases.

It was carefully packed to prevent damage during shipment. Should you feel that the instrument is not functioning properly please check for the following common conditions first:

- ✓ Are all cables connected correctly?
- ✓ Are there any leaks in the installation?
- ✓ Is the power supply correctly selected according to requirements?
When several meters are used a power supply with appropriate current rating should be selected.
- ✓ Were the connector pinouts matched properly? When interchanging with other manufacturers' equipment, cables and connectors must be carefully wired for correct pin configurations.
- ✓ Is the pressure differential across the instrument sufficient?

8.2 General Troubleshooting Guide

INDICATION	LIKELY REASON	REMEDY
lack of reading or output	power supply off	check connection of power supply
	fuse blown	disconnect transducer from power supply; remove the shorting condition or check polarities; fuse resets automatically
	filter screen obstructed at inlet	flush clean or disassemble to remove impediments or replace
	occluded sensor tube	flush clean or disassemble to remove impediments or return to factory for replacement
	pc board defect	return to factory for replacement
	FMA 5400A/5500A Series Max Flow 10, 50, 100 L/min valve adjustment wrong	re-adjust valve (section 8.3.3)
flow reading does not coincide with the setpoint	inadequate gas pressure	apply appropriate gas pressure
	filter screen obstructed at inlet	flush clean or disassemble to remove impediments or replace
	ground loop	signal and power supply commons are different
no response to setpoint	inadequate gas pressure	apply appropriate gas pressure
	cable or connector malfunction	check cables and all connections or replace
	setpoint is too low (<2% of full scale)	re adjust setpoint or disable 2% cutoff feature (section 2.2)
	FMA 5400A/5500A Series Max Flow 10, 50, 100 L/min valve adjustment wrong	re-adjust valve (section 8.3.3 below)
unstable or no zero reading	gas leak	locate and correct
	pc board defective	return to factory for replacement
	FMA 5400A/5500A Series Max Flow 10, 50, 100 L/min valve adjustment wrong	re-adjust valve (see section 8.3.2 below)

INDICATION	LIKELY REASON	REMEDY
full scale output at “no flow” condition or with valve closed	defective sensor	return to factory for replacement
	gas leak	locate and repair
	FMA 5400A/5500A Series Max Flow 10, 50, 100 L/min valve adjustment wrong	re-adjust valve(section 8.3.1 below)
calibration off	gas metered is not the same as what meter was calibrated for	use matched calibration
	composition of gas changed	see K factor tables in APPENDIX 2
	gas leak	locate and correct
	pc board defective	return to factory for replacement
	RFE dirty	flush clean or disassemble to remove impediments
	occluded sensor tube	flush clean or disassemble to remove impediments or return to factory for replacement
	filter screen obstructed at inlet	flush clean or disassemble to remove impediments or replace
	transducer is not mounted properly	check for any tilt or change in the mounting of the transducer; generally, units are calibrated for horizontal installation (relative to the sensor tube)
FMA 5400A/5500A valve does not work in open position	FMA 5400A/5500A Series Max Flow 10, 50, 100 L/min incorrect valve adjustment	re-adjust valve (section 8.3.3)
	pc board defect	return to factory for replacement
	cable or connectors malfunction	check cable and connectors or replace
	differential pressure too high	decrease pressure to correct level
	insufficient inlet pressure	adjust appropriately

INDICATION	LIKELY REASON	REMEDY
FMA 5400A/5500A valve does not work in	FMA 5400A/5500A Series Max Flow 10, 50, 100 L/min incorrect valve adjustment	re-adjust valve (section 8.3.1)
	pc board defect closed position	return to factory for replacement
	cable or connectors malfunction	check cable and connectors or replace
	orifice obstructed	disassemble to remove impediments or return to factory

8.3 FMA 5400A/5500A Series Max. Flow 10, 50 and 100 L/min Valve Related Troubleshooting

8.3.1 INDICATION:	LIKELY REASON:	REMEDY:
With “no flow conditions” (gas pipes are not connected to the FMA 5400A/5500A) and valve closed (pins 3 and 12 are connected together) LCD reading is zero, but when 20 PSIG inlet pressure is applied the LCD reads more than 0.5% of full scale.	Valve is out of adjustment and leaking.	<ol style="list-style-type: none"> 1. Adjust control set point to zero. Set Valve mode to “CLOSE” position (connect pins 3 and 12 on the 15 pins D-connector together). This step is very important! 2. Apply 20 PSIG inlet pressure. 3. See operating manual page 14. Unscrew hex nut cover on the top of the solenoid valve. 4. Using a screwdriver readjust adjustment screw on the top of the valve to CW (clock wise) direction until zero reading on the display. Be very careful during adjustment: make only 15 degree turn each time and wait one minute due to the sensor’s response time. If reading is still high make another 15 degree turn. Do not over adjust valve. If you made more than 5 complete (360 degree) turns and leakage still exists stop adjustment. In this case unit has to be returned to the factory for servicing. 5. This is not a shut off valve. It is normal to observe up to 0.5 % of F.S. leakage. 6. Adjust hex nut cover on the top of the solenoid valve. 7. Disable Valve “Close” mode, apply 100% control set point and check if reading can reach 100% reading.

8.3.2 INDICATION:	LIKELY REASON:	REMEDY:
<p>Differential pressure across the FMA 5400A/5500A controller is within specification but LCD reading and actual flow are not stable (oscillate 1-4 times per second).</p>	<p>Valve compression spring is over adjusted and PID control cannot handle stable flow.</p>	<ol style="list-style-type: none"> 1. Make sure differential pressure across the FMA 5400A/5500A is within specification. 2. Install control set point to 100% F.S. This should remedy the oscillation conditions. 3. See operating manual page 14. Unscrew hex nut cover on the top of the solenoid valve. 4. Using screwdriver readjust adjustment screw on the top of the valve to CCW (counter clock wise) direction until reading on the display will be stable. Be very careful during adjustment: make only 15 degree turn each time and wait about 15 seconds due to sensor's response time. If reading oscillates make another 15 degree turn. Do not over adjust valve. If you noticed that flow rate is constant and more than 105% of full scale, it means you over adjusted valve and it has leakage. In this case make adjustment to CW (clock wise) in order to fix this problem until reading will go back to 100% full scale. 5. Adjust zero set point (or valve close command), wait about 3 minutes and check if valve is able to close. 6. This is not a shut off valve. It is normal to observe up to 0.5 % of F.S. leakage. 7. Install hex nut cover on the top of the solenoid valve.

8.3.3 INDICATION:	LIKELY REASON:	REMEDY:
<p>Differential pressure across the FMA 5400A/5500A controller is within specification but flow rate reading is more than 1% F.S. below set point value when 100% set point is applied.</p>	<p>Valve compression spring is over adjusted and controller does not have enough power to open valve and reach 100% F.S. flow.</p>	<ol style="list-style-type: none"> 1. Make sure differential pressure across the FMA 5400A/5500A is within specification. 2. Adjust control set point to 100% F.S. This should remedy initial fault conditions (flow reading is less than set point value and difference is more than 1% F.S.). 3. See operating manual page 14. Unscrew hex nut cover on the top of the solenoid valve. 4. Using screwdriver readjust adjustment screw on the top of the valve to CCW (counter clock wise) direction until reading on the display will be equal to the set point value. Be very careful during adjustment: make only 15 degree turn each time and wait about 15 seconds due to sensors responds time. If reading still below 100% make another 15 degree turn. Do not over adjust valve. If you noticed that flow rate is constant and more than 105% of full scale, it means you over adjusted valve and it has leakage. In this case make adjustment to CW (clock wise) in order to fix this problem until reading will go back to 100% full scale. 5. Install zero set point (or valve close command), wait about 3 minutes and check if valve is able to close. 6. This is not a shut off valve. It is normal to observe up to 0.5 % of F.S. leakage. 7. Install hex nut cover on the top of the solenoid valve.



NOTE: One common reason for proportional solenoid valve to be out of adjustment: keeping control set point even very small (2% for example) while disconnecting inlet pressure. In this case the valve becomes overheated within 15 minutes and mechanical characteristics of the seat insert and compression spring are compromised. Avoid this mode of operation in the future.

For best results it is recommended that instruments are returned to the factory for servicing. See section 1.3 for return procedures.

8.4 Technical Assistance

OMEGA® Engineering will provide technical assistance over the phone to qualified repair personnel. Please call our Flow Department at 800-872-9436 Ext. 2298.

9. CALIBRATION CONVERSIONS FROM REFERENCE GASES

The calibration conversion incorporates the K factor. The K factor is derived from gas density and coefficient of specific heat. For diatomic gases:

$$K_{\text{gas}} = \frac{1}{d \times C_p}$$

where d = gas density (gram/liter)

C_p = coefficient of specific heat (cal/gram)

Note: in the above relationship that d and C_p are usually chosen at the same conditions (temperature, pressure).

If the flow range of a Mass Flow Controller remains unchanged, a relative K factor is used to relate the calibration of the actual gas to the reference gas.

$$K = \frac{Q_a}{Q_r} = \frac{K_a}{K_r}$$

where Q_a = mass flow rate of an actual gas (sccm)

Q_r = mass flow rate of a reference gas (sccm)

K_a = K factor of an actual gas

K_r = K factor of a reference gas

For example, if we want to know the flow rate of oxygen and wish to calibrate with nitrogen at 1000 SCCM, the flow rate of oxygen is:

$$Q_{O_2} = Q_a = Q_r \times K = 1000 \times 0.9926 = 992.6 \text{ sccm}$$

where K = relative K factor to reference gas (oxygen to nitrogen)

APPENDIX 1

COMPONENTS DIAGRAM

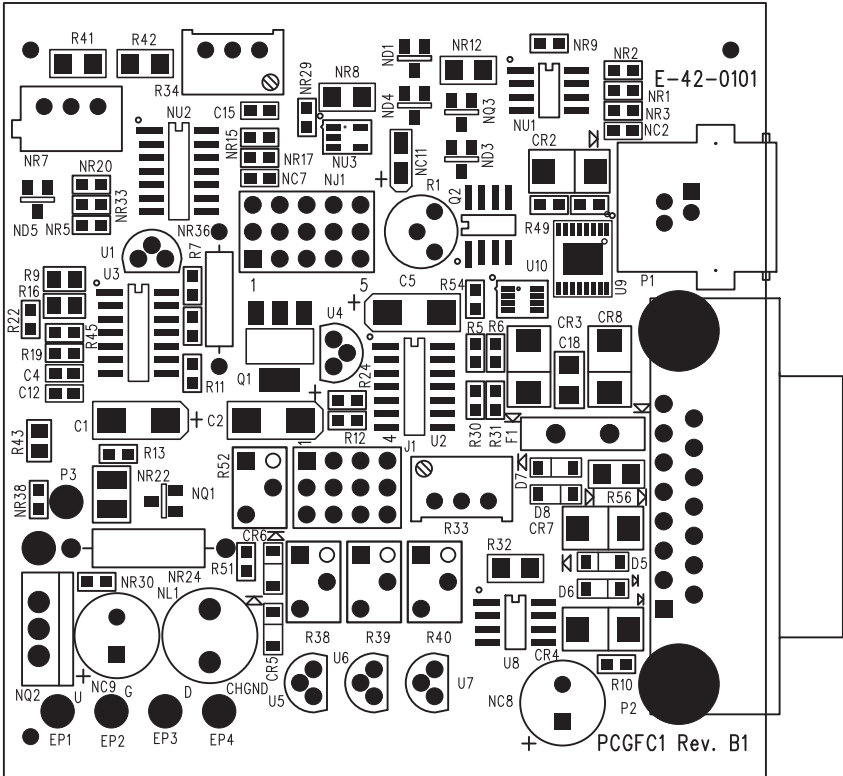

FMA 5400A/5500A SERIES MAX. FLOW 10, 50 AND 100 L/MIN PC BOARD
(TOP SIDE)

COMPONENTS DIAGRAM

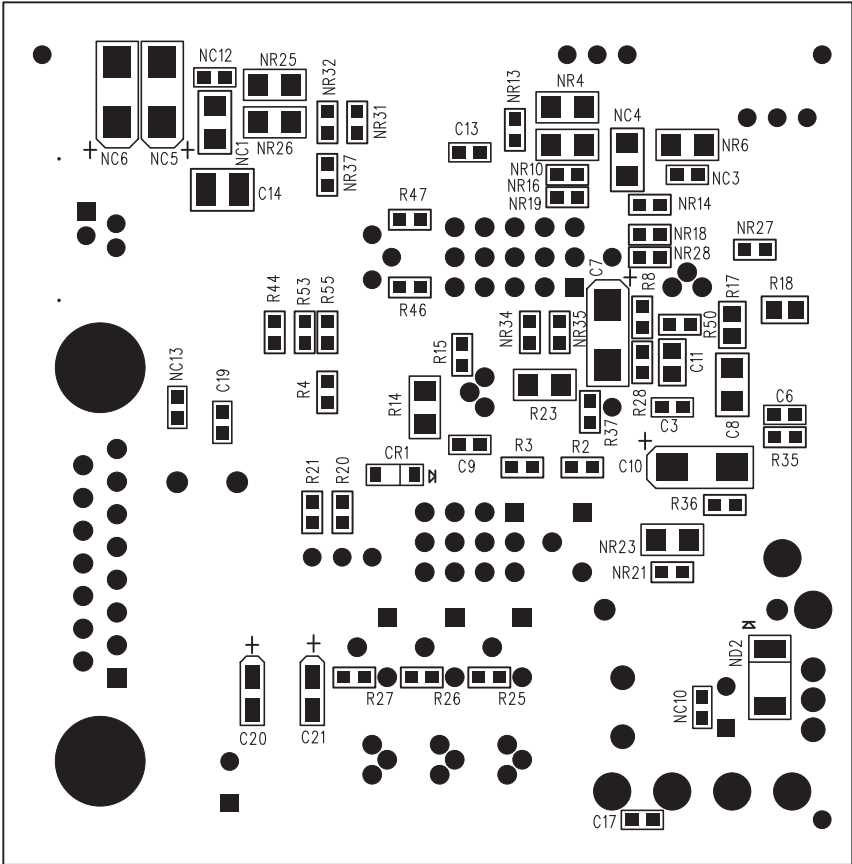

**FMA 5400A/5500A SERIES MAX. FLOW 10, 50 AND 100 L/MIN PC BOARD
(BOTTOM SIDE)**

APPENDIX 2
GAS FACTOR TABLE ("K" FACTORS)

⚠ CAUTION: K-Factors at best are only an approximation. K factors should not be used in applications that require accuracy better than +/- 5 to 10%.

ACTUAL GAS	K FACTOR Relative to N ₂	Cp [Cal/g]	Density [g/l]
Acetylene C ₂ H ₂	.5829	.4036	1.162
Air	1.0000	.240	1.293
Allene (Propadiene) C ₃ H ₄	.4346	.352	1.787
Ammonia NH ₃	.7310	.492	.760
*Argon Ar	1.4573	.1244	1.782
*Argon AR-1 (>10 L/min)	1.205	.1244	1.782
Arsine AsH ₃	.6735	.1167	3.478
Boron Trichloride BCl ₃	.4089	.1279	5.227
Boron Trifluoride BF ₃	.5082	.1778	3.025
Bromine Br ₂	.8083	.0539	7.130
Boron Tribromide Br ₃	.38	.0647	11.18
Bromine PentaTrifluoride BrF ₅	.26	.1369	7.803
Bromine Trifluoride BrF ₃	.3855	.1161	6.108
Bromotrifluoromethane (Freon-13 B1) CBrF ₃	.3697	.1113	6.644
1,3-Butadiene C ₄ H ₆	.3224	.3514	2.413
Butane C ₄ H ₁₀	.2631	.4007	2.593
1-Butene C ₄ H ₈	.2994	.3648	2.503
2-Butene C ₄ H ₈ CIS	.324	.336	2.503
2-Butene C ₄ H ₈ TRANS	.291	.374	2.503
*Carbon Dioxide CO ₂	.7382	.2016	1.964
*Carbon Dioxide CO ₂ -1 (>10 L/min)	.658	.2016	1.964
Carbon Disulfide CS ₂	.6026	.1428	3.397
Carbon Monoxide CO	1.00	.2488	1.250
Carbon Tetrachloride CCl ₄	.31	.1655	6.860
Carbon Tetrafluoride (Freon-14)CF ₄	.42	.1654	3.926
Carbonyl Fluoride COF ₂	.5428	.1710	2.945
Carbonyl Sulfide COS	.6606	.1651	2.680
Chlorine Cl ₂	.86	.114	3.163
Chlorine Trifluoride ClF ₃	.4016	.1650	4.125
Chlorodifluoromethane (Freon-22)CHClF ₂	.4589	.1544	3.858
Chloroform CHCl ₃	.3912	.1309	5.326
Chloropentafluoroethane(Freon-115)C ₂ ClF ₅	.2418	.164	6.892
Chlorotrifluoromethane (Freon-13) CClF ₃	.3834	.153	4.660
Cyanogen C ₂ N ₂	.61	.2613	2.322
CyanogenChloride ClCN	.6130	.1739	2.742
Cyclopropane C ₃ H ₅	.4584	.3177	1.877

* Flow rates indicated () is the maximum flow range of the Mass Flow meter being used.

ACTUAL GAS	K FACTOR Relative to N ₂	Cp [Cal/g]	Density [g/l]
Deuterium D ₂	1.00	1.722	1.799
Diborane B ₂ H ₆	.4357	.508	1.235
Dibromodifluoromethane CBr ₂ F ₂	.1947	.15	9.362
Dichlorodifluoromethane (Freon-12) CCl ₂ F ₂	.3538	.1432	5.395
Dichlorofluoromethane (Freon-21) CHCl ₂ F	.4252	.140	4.592
Dichloromethylsilane (CH ₃) ₂ SiCl ₂	.2522	.1882	5.758
Dichlorosilane SiH ₂ Cl ₂	.4044	.150	4.506
Dichlorotetrafluoroethane (Freon-114) C ₂ Cl ₂ F ₄	.2235	.1604	7.626
1,1-Difluoroethylene (Freon-1132A) C ₂ H ₂ F ₂	.4271	.224	2.857
Dimethylamine (CH ₃) ₂ NH	.3714	.366	2.011
Dimethyl Ether (CH ₃) ₂ O	.3896	.3414	2.055
2,2-Dimethylpropane C ₃ H ₁₂	.2170	.3914	3.219
Ethane C ₂ H ₆	.50	.420	1.342
Ethanol C ₂ H ₆ O	.3918	.3395	2.055
Ethyl Acetylene C ₄ H ₆	.3225	.3513	2.413
Ethyl Chloride C ₂ H ₅ Cl	.3891	.244	2.879
Ethylene C ₂ H ₄	.60	.365	1.251
Ethylene Oxide C ₂ H ₄ O	.5191	.268	1.965
Fluorine F ₂	.9784	.1873	1.695
Fluoroform (Freon-23) CHF ₃	.4967	.176	3.127
Freon-11 CCl ₃ F	.3287	.1357	6.129
Freon-12 CCl ₂ F ₂	.3538	.1432	5.395
Freon-13 CClF ₃	.3834	.153	4.660
Freon-13B1 CBrF ₃	.3697	.1113	6.644
Freon-14 CF ₄	.4210	.1654	3.926
Freon-21 CHCl ₂ F	.4252	.140	4.592
Freon-22 CHClF ₂	.4589	.1544	3.858
Freon-113 CCl ₂ FCF ₂	.2031	.161	8.360
Freon-114 C ₂ Cl ₂ F ₄	.2240	.160	7.626
Freon-115 C ₂ ClF ₅	.2418	.164	6.892
Freon-C318 C ₄ F ₈	.1760	.185	8.397
Germane GeH ₄	.5696	.1404	3.418
Germanium Tetrachloride GeCl ₄	.2668	.1071	9.565
*Helium He	1.454	1.241	.1786
*Helium He-1 (>50 L/min)	2.43	1.241	.1786
*Helium He-2 (>10-50 L/min)	2.05	1.241	.1786
Hexafluoroethane C ₂ F ₆ (Freon-116)	.2421	.1834	6.157
Hexane C ₆ H ₁₄	.1792	.3968	3.845
*Hydrogen H ₂ -1	1.0106	3.419	.0899
*Hydrogen H ₂ -2 (>10-100 L)	1.35	3.419	.0899
*Hydrogen H ₂ -3 (>100 L)	1.9	3.419	.0899

* Flow rates indicated () is the maximum flow range of the Mass Flow meter being used.

ACTUAL GAS	K FACTOR Relative to N ₂	Cp [Cal/g]	Density [g/l]
Hydrogen Bromide HBr	1.000	.0861	3.610
Hydrogen Chloride HCl	1.000	.1912	1.627
Hydrogen Cyanide HCN	.764	.3171	1.206
Hydrogen Fluoride HF	.9998	.3479	.893
Hydrogen Iodide HI	.9987	.0545	5.707
Hydrogen Selenide H ₂ Se	.7893	.1025	3.613
Hydrogen Sulfide H ₂ S	.80	.2397	1.520
Iodine Pentafluoride IF ₅	.2492	.1108	9.90
Isobutane CH(CH ₃) ₃	.27	.3872	3.593
Isobutylene C ₄ H ₆	.2951	.3701	2.503
Krypton Kr	1.453	.0593	3.739
*Methane CH ₄	.7175	.5328	.7175
*Methane CH ₄ -1 (>10 L/min)	.75	.5328	.7175
Methanol CH ₃	.5843	.3274	1.429
Methyl Acetylene C ₃ H ₄	.4313	.3547	1.787
Methyl Bromide CH ₃ Br	.5835	.1106	4.236
Methyl Chloride CH ₃ Cl	.6299	.1926	2.253
Methyl Fluoride CH ₃ F	.68	.3221	1.518
Methyl Mercaptan CH ₃ SH	.5180	.2459	2.146
Methyl Trichlorosilane (CH ₃)SiCl ₃	.2499	.164	6.669
Molybdenum Hexafluoride MoF ₆	.2126	.1373	9.366
Monoethylamine C ₂ H ₅ NH ₂	.3512	.387	2.011
Monomethylamine CH ₃ NH ₂	.51	.4343	1.386
Neon NE	1.46	.246	.900
Nitric Oxide NO	.990	.2328	1.339
Nitrogen N ₂	1.000	.2485	1.25
Nitrogen Dioxide NO ₂	.737	.1933	2.052
Nitrogen Trifluoride NF ₃	.4802	.1797	3.168
Nitrosyl Chloride NOCl	.6134	.1632	2.920
Nitrous Oxide N ₂ O	.7128	.2088	1.964
Octafluorocyclobutane (Freon-C318) C ₄ F ₈	.176	.185	8.397
Oxygen O ₂	.9926	.2193	1.427
Oxygen Difluoride OF ₂	.6337	.1917	2.406
Ozone	.446	.195	2.144
Pentaborane B ₅ H ₉	.2554	.38	2.816
Pentane C ₅ H ₁₂	.2134	.398	3.219
Perchloryl Fluoride ClO ₃ F	.3950	.1514	4.571
Perfluoropropane C ₃ F ₈	.174	.197	8.388
Phosgene COCl ₂	.4438	.1394	4.418
Phosphine PH ₃	.759	.2374	1.517

* Flow rates indicated () is the maximum flow range of the Mass Flow meter being used.

ACTUAL GAS	K FACTOR Relative to N ₂	Cp [Cal/g]	Density [g/l]
Phosphorous Oxychloride POCl ₃	.36	.1324	6.843
Phosphorous Pentafluoride PH ₅	.3021	.1610	5.620
Phosphorous Trichloride PCl ₃	.30	.1250	6.127
Propane C ₃ H ₈	.35	.399	1.967
Propylene C ₃ H ₆	.40	.366	1.877
Silane SiH ₄	.5982	.3189	1.433
Silicon Tetrachloride SiCl ₄	.284	.1270	7.580
Silicon Tetrafluoride SiF ₄	.3482	.1691	4.643
Sulfur Dioxide SO ₂	.69	.1488	2.858
Sulfur Hexafluoride SF ₆	.2635	.1592	6.516
Sulfuryl Fluoride SO ₂ F ₂	.3883	.1543	4.562
Tetrafluoroethane (Forane 134A) CF ₃ CH ₂ F	.5096	.127	4.224
Tetrafluorohydrazine N ₂ F ₄	.3237	.182	4.64
Trichlorofluoromethane (Freon-11) CCl ₃ F	.3287	.1357	6.129
Trichlorosilane SiHCl ₃	.3278	.1380	6.043
1,1,2-Trichloro-1,2,2 Trifluoroethane (Freon-113) CCl ₂ FCF ₂	.2031	.161	8.36
Triisobutyl Aluminum (C ₄ H ₉) ₃ Al	.0608	.508	8.848
Titanium Tetrachloride TiCl ₄	.2691	.120	8.465
Trichloro Ethylene C ₂ HCl ₃	.32	.163	5.95
Trimethylamine (CH ₃) ₃ N	.2792	.3710	2.639
Tungsten Hexafluoride WF ₆	.2541	.0810	13.28
Vinyl Bromide CH ₂ CHBr	.4616	.1241	4.772
Vinyl Chloride CH ₂ CHCl	.48	.12054	2.788
Xenon Xe	1.44	.0378	5.858

APPENDIX 3

DIMENSIONAL DRAWINGS

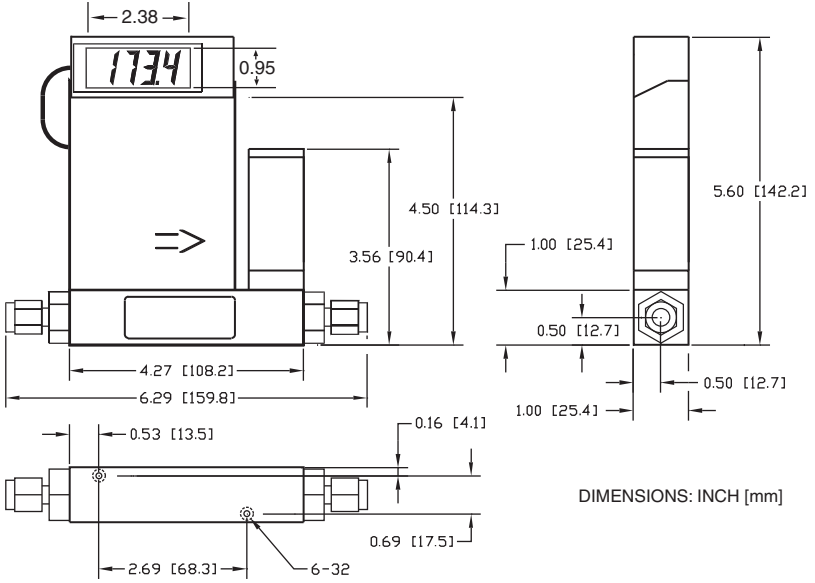

SERIES MAX. FLOW 10 L/min MASS FLOW CONTROLLER

NOTE: OMEGA® reserves the right to change designs and dimensions at its sole discretion at any time without notice. For certified dimensions please contact OMEGA®.

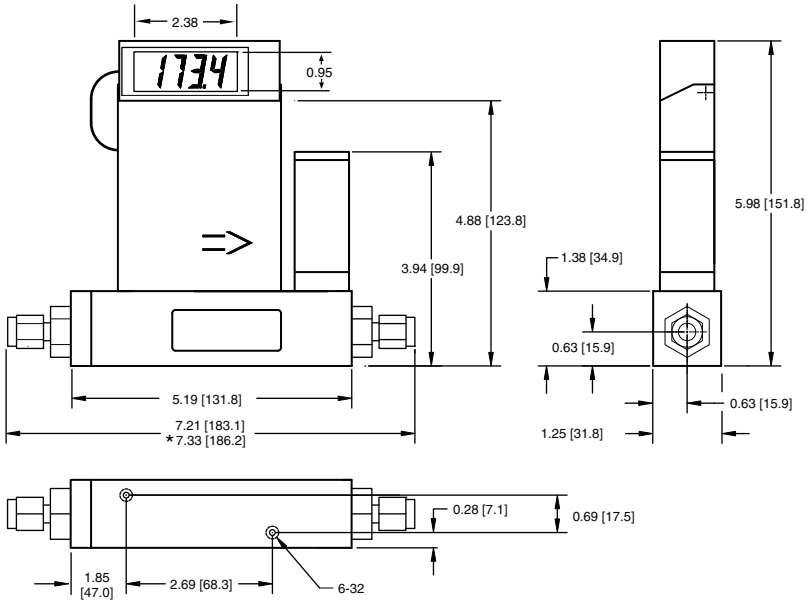

* FOR HIGH FLOW MASS FLOW CONTROLLER ONLY
 DIMENSIONS: INCH [mm]

SERIES MAX FLOW 15 - 100 L/min MASS FLOW CONTROLLER

NOTE: OMEGA reserves the right to change designs and dimensions at its sole discretion at any time without notice. For certified dimensions please contact OMEGA.

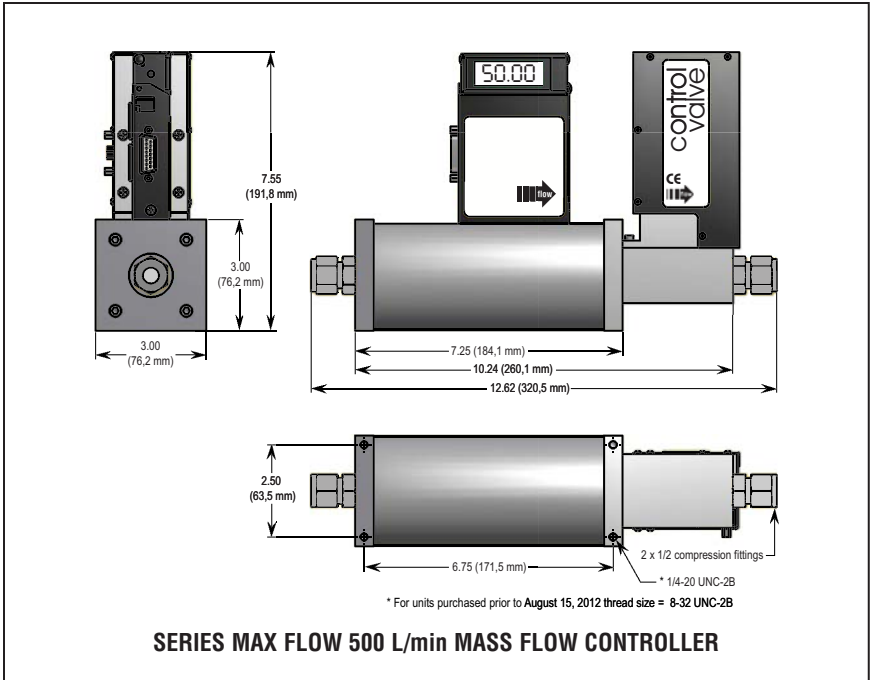
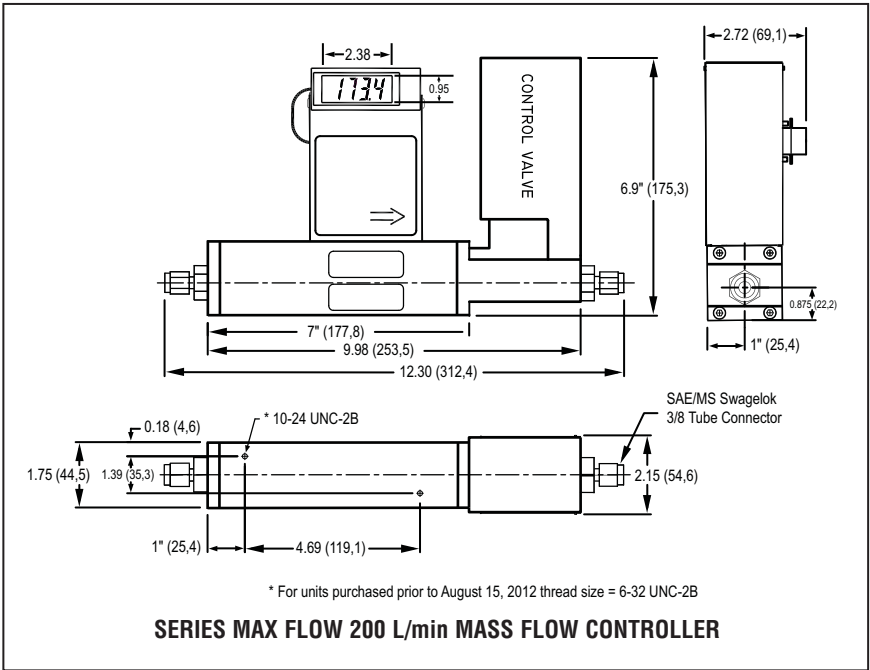

NOTE: OMEGA reserves the right to change designs and dimensions at its sole discretion at any time without notice. For certified dimensions please contact OMEGA.

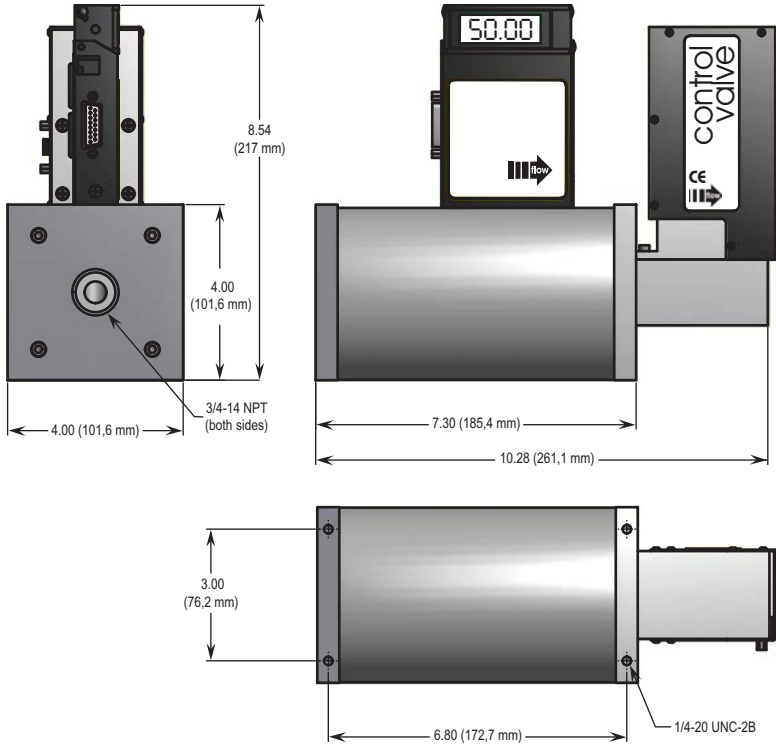

SERIES MAX FLOW 1000 L/min MASS FLOW CONTROLLER

NOTE: OMEGA reserves the right to change designs and dimensions at its sole discretion at any time without notice. For certified dimensions please contact OMEGA.



WARRANTY/DISCLAIMER

OMEGA ENGINEERING, INC. warrants this unit to be free of defects in materials and workmanship for a period of **13 months** from date of purchase. OMEGA's WARRANTY adds an additional one (1) month grace period to the normal **one (1) year product warranty** to cover handling and shipping time. This ensures that OMEGA's customers receive maximum coverage on each product.

If the unit malfunctions, it must be returned to the factory for evaluation. OMEGA's Customer Service Department will issue an Authorized Return (AR) number immediately upon phone or written request. Upon examination by OMEGA, if the unit is found to be defective, it will be repaired or replaced at no charge. OMEGA's WARRANTY does not apply to defects resulting from any action of the purchaser, including but not limited to mishandling, improper interfacing, operation outside of design limits, improper repair, or unauthorized modification. This WARRANTY is VOID if the unit shows evidence of having been tampered with or shows evidence of having been damaged as a result of excessive corrosion; or current, heat, moisture or vibration; improper specification; misapplication; misuse or other operating conditions outside of OMEGA's control. Components in which wear is not warranted, include but are not limited to contact points, fuses, and triacs.

OMEGA is pleased to offer suggestions on the use of its various products. However, OMEGA neither assumes responsibility for any omissions or errors nor assumes liability for any damages that result from the use of its products in accordance with information provided by OMEGA, either verbal or written. OMEGA warrants only that the parts manufactured by the company will be as specified and free of defects. OMEGA MAKES NO OTHER WARRANTIES OR REPRESENTATIONS OF ANY KIND WHATSOEVER, EXPRESSED OR IMPLIED, EXCEPT THAT OF TITLE, AND ALL IMPLIED WARRANTIES INCLUDING ANY WARRANTY OF MERCHANTABILITY AND FITNESS FOR A PARTICULAR PURPOSE ARE HEREBY DISCLAIMED. LIMITATION OF LIABILITY: The remedies of purchaser set forth herein are exclusive, and the total liability of OMEGA with respect to this order, whether based on contract, warranty, negligence, indemnification, strict liability or otherwise, shall not exceed the purchase price of the component upon which liability is based. In no event shall OMEGA be liable for consequential, incidental or special damages.

CONDITIONS: Equipment sold by OMEGA is not intended to be used, nor shall it be used: (1) as a "Basic Component" under 10 CFR 21 (NRC), used in or with any nuclear installation or activity; or (2) in medical applications or used on humans. Should any Product(s) be used in or with any nuclear installation or activity, medical application, used on humans, or misused in any way, OMEGA assumes no responsibility as set forth in our basic WARRANTY/DISCLAIMER language, and, additionally, purchaser will indemnify OMEGA and hold OMEGA harmless from any liability or damage whatsoever arising out of the use of the Product(s) in such a manner.

RETURN REQUESTS/INQUIRIES

Direct all warranty and repair requests/inquiries to the OMEGA Customer Service Department. BEFORE RETURNING ANY PRODUCT(S) TO OMEGA, PURCHASER MUST OBTAIN AN AUTHORIZED RETURN (AR) NUMBER FROM OMEGA'S CUSTOMER SERVICE DEPARTMENT (IN ORDER TO AVOID PROCESSING DELAYS). The assigned AR number should then be marked on the outside of the return package and on any correspondence.

The purchaser is responsible for shipping charges, freight, insurance and proper packaging to prevent breakage in transit.

FOR **WARRANTY** RETURNS, please have the following information available BEFORE contacting OMEGA:

1. Purchase Order number under which the product was PURCHASED,
2. Model and serial number of the product under warranty, and
3. Repair instructions and/or specific problems relative to the product.

FOR **NON-WARRANTY** REPAIRS, consult OMEGA for current repair charges. Have the following information available BEFORE contacting OMEGA:

1. Purchase Order number to cover the COST of the repair,
2. Model and serial number of the product, and
3. Repair instructions and/or specific problems relative to the product.

OMEGA's policy is to make running changes, not model changes, whenever an improvement is possible. This affords our customers the latest in technology and engineering.

OMEGA is a registered trademark of OMEGA ENGINEERING, INC.

© Copyright 2009 OMEGA ENGINEERING, INC. All rights reserved. This document may not be copied, photocopied, reproduced, translated, or reduced to any electronic medium or machine-readable form, in whole or in part, without the prior written consent of OMEGA ENGINEERING, INC.

Where Do I Find Everything I Need for Process Measurement and Control? **OMEGA...Of Course!** *Shop online at omega.comSM*

TEMPERATURE

- ☑ Thermocouple, RTD & Thermistor Probes, Connectors, Panels & Assemblies
- ☑ Wire: Thermocouple, RTD & Thermistor
- ☑ Calibrators & Ice Point References
- ☑ Recorders, Controllers & Process Monitors
- ☑ Infrared Pyrometers

PRESSURE, STRAIN AND FORCE

- ☑ Transducers & Strain Gages
- ☑ Load Cells & Pressure Gages
- ☑ Displacement Transducers
- ☑ Instrumentation & Accessories

FLOW/LEVEL

- ☑ Rotameters, Gas Mass Flowmeters & Flow Computers
- ☑ Air Velocity Indicators
- ☑ Turbine/Paddlewheel Systems
- ☑ Totalizers & Batch Controllers

pH/CONDUCTIVITY

- ☑ pH Electrodes, Testers & Accessories
- ☑ Benchtop/Laboratory Meters
- ☑ Controllers, Calibrators, Simulators & Pumps
- ☑ Industrial pH & Conductivity Equipment

DATA ACQUISITION

- ☑ Data Acquisition & Engineering Software
- ☑ Communications-Based Acquisition Systems
- ☑ Plug-in Cards for Apple, IBM & Compatibles
- ☑ Datalogging Systems
- ☑ Recorders, Printers & Plotters

HEATERS

- ☑ Heating Cable
- ☑ Cartridge & Strip Heaters
- ☑ Immersion & Band Heaters
- ☑ Flexible Heaters
- ☑ Laboratory Heaters

ENVIRONMENTAL MONITORING AND CONTROL

- ☑ Metering & Control Instrumentation
- ☑ Refractometers
- ☑ Pumps & Tubing
- ☑ Air, Soil & Water Monitors
- ☑ Industrial Water & Wastewater Treatment
- ☑ pH, Conductivity & Dissolved Oxygen Instruments